

CHAPTER 17

PO 370 – RECOGNIZE ASPECTS OF AIRCRAFT MANUFACTURING AND MAINTENANCE



ROYAL CANADIAN AIR CADETS
PROFICIENCY LEVEL THREE
INSTRUCTIONAL GUIDE



SECTION 1

EO M370.01 – IDENTIFY COMPONENTS OF THE PITOT STATIC SYSTEM

Total Time: 30 min

PREPARATION

PRE-LESSON INSTRUCTIONS

Resources needed for the delivery of this lesson are listed in the lesson specification located in A-CR-CCP-803/PG-001, Chapter 4. Specific uses for said resources are identified throughout the instructional guide within the TP for which they are required.

Review the lesson content and become familiar with the material prior to delivering the lesson.

Create slides of Annexes A and B.

PRE-LESSON ASSIGNMENT

N/A.

APPROACH

An interactive lecture was chosen for this lesson to review, clarify, emphasize, and summarize the pitot static system.

INTRODUCTION

REVIEW

N/A.

OBJECTIVES

By the end of this lesson the cadet shall have identified components of the pitot static system used in aircraft.

IMPORTANCE

It is important for cadets to identify components of the pitot static system because it is an important part of most aircraft. Familiarity with this system will allow cadets to gain an understanding of this common aircraft feature as it applies to both manufacturing and maintenance of aircraft.

Teaching Point 1

Explain the Pitot Static System

Time: 10 min

Method: Interactive Lecture

Flight instruments enable an aircraft to be operated with maximum performance and safety. One set of flight instruments, those of the pitot static system, measure and utilize air pressure.



Show the cadets Figure 17A-1.

There are two major parts of the pitot static system:

- the static pressure vent and lines, and
- the pitot pressure, also called impact pressure, chamber and lines.

The static pressure line provides the source of ambient (normal outside) air pressure for the operation of the altimeter, vertical speed indicator, and airspeed indicator, while the pitot pressure, or impact pressure line provides impact pressure to the airspeed indicator. The airspeed indicator is the only instrument that requires both air pressures.

STATIC VENT

The static vent is located where the air flowing past the aircraft will not disturb air pressure. This will vary with each model of aircraft. The static vent provides undisturbed air pressure for the static line.

The openings of the static vent must be checked during the pre-flight inspection to ensure that they are free from obstructions. Blocked or partially blocked openings should be cleaned by a certified mechanic. Blowing into these openings is not recommended because this could damage the instruments.

STATIC LINE

The static line is a hollow tube. Since the static line is vented to the free undisturbed air by the static vent, air pressure in the static line will change as the air pressure around the aircraft changes. As the aircraft gains altitude, air pressure in the static line will drop. This pressure change is transmitted through the static line to the instruments which utilize static air pressure. These instruments include the:

- altimeter,
- vertical speed indicator, and
- airspeed indicator.

PITOT PRESSURE CHAMBER

In the pitot static system, the impact air pressure (air striking the airplane because of its forward motion) is taken from a pitot tube. It is mounted in a location that provides minimum disturbance or turbulence caused by the motion of the aircraft through the air. Often, a pitot tube cover is placed over the pitot tube when the aircraft is parked to prevent foreign objects, such as insects, from entering the pitot static system. It is important that the pitot tube cover, if used, is removed prior to takeoff.

As the aircraft moves through the air, the impact pressure on the open pitot tube affects the pressure in the pitot pressure chamber. Any change of pitot (impact) pressure in the pitot pressure chamber is transmitted through a line connected to the airspeed indicator, which uses impact pressure for its operation.

In some aircraft, the static pressure is obtained at the same location as the pitot pressure. This is done by using a hybrid pitot-static tube. In a pitot-static tube, the static vent is combined with the impact tube. The effects are the same.



Show the cadets Figure 17A-2.

The opening of the pitot tube must be checked during the pre-flight inspection to assure that it is free from obstructions. Blocked or partially blocked openings should be cleaned by a certified mechanic. Blowing into these openings is not recommended because this could damage the instruments.

PITOT LINE

Any change of pressure in the pitot chamber is transmitted through a pitot line (a hollow tube) to the airspeed indicator, which uses impact pressure as well as static pressure for its operation.

OPERATION OF THE PITOT STATIC SYSTEM

As described above, the pitot static system of chambers and lines delivers two types of air pressure to flight instruments:

- static pressure, and
- pitot pressure.

When flight instruments are calibrated correctly, they will measure the air pressure that is delivered to them, relative to air pressure at sea level as well as impact pressure relative to static pressure. By measuring the air pressures in the static pressure and impact pressure lines, the calibrated instruments will present useful information about the aircraft's position to the pilot.

Pitot static instrument error will almost always indicate blockage of the pitot tube, the static port, or both.

CONFIRMATION OF TEACHING POINT 1

QUESTIONS

- Q1. What is the pitot static system used for?
- Q2. How is static pressure change delivered to the instruments?
- Q3. Which instrument measures pitot (impact) pressure?

ANTICIPATED ANSWERS

- A1. For operating instruments that measure and use air pressure.
- A2. It is delivered through lines.
- A3. The airspeed indicator.

Teaching Point 2**Explain Instruments of the Pitot Static System**

Time: 15 min

Method: Interactive Lecture

AIRSPEED INDICATOR

Show the cadets Figures 17B-1 and 17B-2.

The airspeed indicator is a sensitive, differential pressure gauge, which measures and shows the difference between pitot, or impact, pressure and static pressure. These two pressures will be equal when the airplane is parked on the ground in calm air. When the aircraft moves through the air, the pressure in the pitot line becomes greater than the pressure in the static line. This difference in pressure is registered by the airspeed pointer on the face of the instrument, which is calibrated in miles per hour, knots, or both.

As the pressure in the pitot tube and pitot line increases, the diaphragm in the airspeed indicator expands. The diaphragm will then maintain its size while the impact pressure is stable. As the impact pressure decreases, the diaphragm contracts accordingly. This expansion and contraction of the diaphragm is reflected in the readout of the airspeed indicator via a system of gears and shafts.

Prior to takeoff, the airspeed indicator should read zero unless there is a strong wind blowing directly into the pitot tube.

VERTICAL SPEED INDICATOR

Show the cadets Figures 17B-3 and 17B-4.

The vertical speed indicator (VSI), sometimes called a vertical velocity indicator (VVI), indicates whether the airplane is climbing, descending, or in level flight. The rate of climb or descent is indicated in thousands of feet per minute. If properly calibrated, the VSI indicates zero in level flight.

Although the VSI operates solely from static pressure, it measures pressure difference; the pressure now relative to the pressure a moment ago. It contains a diaphragm with connecting linkage and gearing to the indicator pointer inside an airtight case. The inside of the diaphragm is connected directly to the static line of the pitot static system. The area outside the diaphragm, which is inside the instrument case, is also connected to the static line, but through a restricted orifice (calibrated leak).

Both the diaphragm and the case receive air from the static line at existing atmospheric pressure. When the airplane is on the ground or in level flight, the pressures inside the diaphragm and the instrument case remain the same and the pointer indicates zero.

However, when the aircraft climbs or descends, the pressure inside the diaphragm changes immediately, but due to the metering action of the restricted passage, the case pressure remains higher or lower for a short time, causing the diaphragm to contract or expand. This causes a pressure difference that is relative to climb rate and is indicated on the instrument needle as a climb or descent.

ALTIMETER

Show the cadets Figures 17B-5 and 17B-6.

The altimeter measures the height of the aircraft above sea level. Since it is the only instrument that gives altitude information, the altimeter is one of the most vital instruments in the aircraft. However, the altimeter is calibrated with respect to standard atmospheric conditions, while air will actually seldom meet those standard conditions. Variations in atmospheric pressure and temperature will introduce errors into the altimeter's measurements. To use the altimeter effectively, its operation and how atmospheric pressure and temperature affect it must be thoroughly understood.

A stack of sealed aneroid wafers comprises the main component of the altimeter. Aneroid wafers expand and contract with changes in atmospheric pressure, in this case, pressure from the static source. The mechanical linkage translates these changes into pointer movements on the indicator.

The pressure altimeter is an adaptation of an aneroid barometer that measures the pressure of the atmosphere at the level where the altimeter is located and presents it as an altitude indication in feet instead of simple air pressure, as a barometer would. The altimeter uses static pressure as its source of operation. Air is denser at sea level than aloft, so as altitude increases, atmospheric pressure decreases. This difference in pressure at various levels causes the altimeter to indicate changes in altitude.

Since altimeters are calibrated with respect to standard atmospheric conditions as described above, it is necessary to adjust altimeters to non-standard static pressures that result from weather fronts. For example, if flying from a high-pressure area to a low-pressure area without adjusting the altimeter, the actual altitude of the aircraft would be LOWER than the indicated altitude because the altimeter was originally set to compensate for a non-standard high air pressure. Arriving in the low-pressure area, it must be reset to compensate for a non-standard low air pressure.

An old saying, "High to low, look out below" is a way of remembering which condition is most dangerous. When flying from a low-pressure area to a high-pressure area without adjusting the altimeter, the actual altitude of the airplane is HIGHER than the indicated altitude because the altimeter was originally set to compensate for a non-standard low air pressure. Arriving in the high-pressure area, it must be reset to compensate for a non-standard high air pressure.

CONFIRMATION OF TEACHING POINT 2

QUESTIONS

- Q1. What does an airspeed indicator measure?
- Q2. What does a vertical speed indicator measure?
- Q3. What does an altimeter measure?

ANTICIPATED ANSWERS

- A1. The difference between static pressure and pitot, or impact, pressure.
- A2. The difference between static air pressure now and static air pressure a moment ago.
- A3. The difference between static air pressure and a standard air pressure, usually at sea level.

END OF LESSON CONFIRMATION

QUESTIONS

- Q1. Which flight instrument measures pitot, or impact pressure?
- Q2. Why are pitot tube covers used?
- Q3. What is the difference between a pitot tube and a pitot-static tube?

ANTICIPATED ANSWERS

- A1. The airspeed indicator.
- A2. To prevent blockage of the pitot tube when the aircraft is parked.
- A3. A pitot-static tube is a combination of a pitot tube with a static vent.

CONCLUSION

HOMEWORK/READING/PRACTICE

N/A.

METHOD OF EVALUATION

N/A.

CLOSING STATEMENT

The pitot static system, which is based on different air pressures, is found on most aircraft. Understanding how the system works allows a pilot or mechanic to use instruments correctly and to diagnose problems that are encountered with pitot static systems.

INSTRUCTOR NOTES/REMARKS

N/A.

REFERENCES

- C3-116 (ISBN 0-9680390-5-7) MacDonald, A. F., & Peppler, I. L. (2000). *From the Ground Up: Millennium Edition*. Ottawa, ON: Aviation Publishers Co. Limited.



ROYAL CANADIAN AIR CADETS
PROFICIENCY LEVEL THREE
INSTRUCTIONAL GUIDE



SECTION 2

EO M370.02 – IDENTIFY AIRCRAFT MANUFACTURERS

Total Time:	30 min
-------------	--------

PREPARATION

PRE-LESSON INSTRUCTIONS

Resources needed for the delivery of this lesson are listed in the lesson specification located in A-CR-CCP-803/PG-001, Chapter 4. Specific uses for said resources are identified throughout the instructional guide within the TP for which they are required.

Review the lesson content and become familiar with the material prior to delivering the lesson.

Update the information located at Annexes C to I using the reference.

Create slides of Annexes C to I.

Prepare the video *Viking Video Profile*. This will be shown in TP 1.

Create slides of aircraft located at Annexes C to H with titles blocked out for use in TP 3.

PRE-LESSON ASSIGNMENT

N/A.

APPROACH

An interactive lecture was chosen for TPs 1 and 2 to orient the cadets to aircraft manufacturing companies, give an overview of them and to generate interest.

An in-class activity was chosen for TP 3 as it is an interactive way to allow cadets to test their ability to identify aircraft manufacturers.

INTRODUCTION

REVIEW

N/A.

OBJECTIVES

By the end of this lesson the cadet shall have identified manufacturers of light and heavy aircraft that are commonly found at Canadian aerodromes.

IMPORTANCE

It is important for cadets to identify manufacturers of aircraft as this will enhance their enjoyment of aviation and will help them identify aircraft they observe at Canadian aerodromes.

Teaching Point 1**Discuss Manufacturers of Light Aircraft**

Time: 15 min

Method: Interactive Lecture

CESSNA AIRCRAFT COMPANY

The Cessna Aircraft Company traces its history to June 1911, when Clyde Cessna, a farmer in Rago, Kansas, built a wood-and-fabric plane and became the first person to build and fly an aircraft between the Mississippi River and the Rocky Mountains.

Over the years since 1911, Cessna has produced many different types of aircraft and many of the models had variations.



Show the cadets the list of Cessna aircraft located at Annex C.



A rented Cessna 172 Skyhawk is often used for air cadet familiarization flying exercises.



Show the cadets Figures 17C-2 to 17C-5, identifying each type of aircraft. Mention that the Cessna 305 is used as a glider tow plane in the Air Cadet Gliding Program.

DIAMOND AIRCRAFT INDUSTRIES

The Diamond story began in 1981 when Hoffmann Flugzeugbau was founded in Friesach, Austria, to produce the newly certified H36 Dimona motorglider. In 1992, the company, then known as Dimona Aircraft, established a full production facility in London, Ont., with a view to supplying the US market with its new aircraft. Later, after modifying its name to Diamond, the company grew into an international manufacturer with over 46 000 sq m of modern production facilities, over 800 employees, five distinct product lines, and facilities on three continents. The company's operation at the London, Ont. airport has over 23 000 sq m of state-of-the-art production facilities to design, build and test aircraft.

Diamond produces a variety of aircraft types, including:

- DA20, a single-engine propeller-driven aircraft,
- DA42, a twin-engine propeller-driven aircraft, and
- D-JET, a single-engine gas turbine fanjet.



Show the cadets the figures located at Annex D, identifying each type of aircraft.

PIPER AIRCRAFT, INC

Originally founded as the Taylor Brothers Aircraft Manufacturing Company in September 1927, the company was renamed Taylor Brothers Aircraft Corporation in April of 1928 and then Piper Aircraft Corporation in November 1937.

Now located at Vero Beach, Florida, Piper's manufacturing capabilities cover a wide variety of fabrication, assembly, paint and inspection processes. The company also designs and builds its own tooling. Piper's engineering design work is also comprehensive, with separate engineering groups responsible for aircraft certification, production support, customer service engineering, product development, engineering administration and test operations.



Show the cadets the figures located at Annex E, identifying each type of aircraft.

VIKING AIR

Viking Air is a manufacturing, maintenance and leasing company located at the Victoria International Airport in Sidney, B.C.



Viking Air, although a very small company by Canadian aviation standards, purchased the type certificates for seven de Havilland heritage aircraft, giving Viking the exclusive right to re-start production for any of these seven de Havilland Canada aircraft types.

Viking Air holds the Type Certificates for the following de Havilland aircraft:

- DHC-1 Chipmunk,
- DHC-2 Beaver,
- DHC-3 Otter,
- DHC-4 Caribou,
- DHC-5 Buffalo,
- DHC-6 Twin Otter, and
- DHC-7 Dash 7.

The DHC-6 Twin Otter and DHC-2 Beaver remain popular in commercial aviation, while the DHC-5 Buffalo continues to serve the CF in a Search and Rescue capacity.



Show the cadets the figures located at Annex F, identifying each type of aircraft.



Show the cadets the six-minute video *Viking Video Profile* (Reference C3-203).

CONFIRMATION OF TEACHING POINT 1

Participation in the aircraft identification activity at the end of this lesson will serve as the confirmation of TP 1.

Teaching Point 2

Discuss Manufacturers of Heavy Aircraft

Time: 5 min

Method: Interactive Lecture

AIRBUS

Airbus is one of the world's two leading aircraft manufacturers. The company employs 57 000 people and produces a comprehensive range of heavy commercial aircraft.

Manufacturing, production and sub-assembly of parts for Airbus aircraft are distributed around 16 sites in Europe, with final assembly in Toulouse, France and Hamburg, Germany. Airbus draws on a global network of more than 1 500 suppliers in over 30 countries.

There are also centres for engineering design, sales and customer support in North America; and sales and customer support centres in Japan and China. Airbus has a joint engineering centre in Russia with Kaskol, a Russian aircraft manufacturer.

Around the world, Airbus has 5 spare parts centres, 160 field sites, 3 training centres in Toulouse, Miami and Beijing and one A320 maintenance training centre in Hamburg. Airbus has an agreement with CAE (formerly Canadian Aviation Electronics Ltd.) to provide Airbus-approved training courses in many other sites around the world.



Show the cadets the figures located at Annex G, identifying each type of aircraft.

THE BOEING COMPANY

Headquartered in Chicago, Illinois, Boeing employs more than 150 000 people across the United States and in 70 other countries, with major operations in the Puget Sound area of Washington State, southern California and St. Louis, Missouri.

For more than a century, Boeing has produced a vast number of aircraft types. Some Boeing aircraft had historical significance that extended well beyond aviation; they actually changed the world. For example, America entered the age of jet transport on July 15, 1954, when the Boeing 707 prototype, the model 367-

80, made its maiden flight from Renton Field, south of Seattle, Washington. Forerunner of the more than 14 000 Boeing jetliners built afterwards, the prototype, nicknamed the “Dash 80,” served 18 years as a flying test laboratory before it was turned over to the Smithsonian Air and Space Museum in May 1972. The Boeing 707 was a very successful aircraft type.



Show the cadets the Figure 17H-1.

Other popular Boeing aircraft, that are commonly seen, include the:

- Boeing 737,
- Boeing 747,
- Boeing 767, and
- Boeing 777.



Show the cadets the remaining figures located at Annex H, identifying each type of aircraft.

Different aircraft are suitable for different routes, depending on such things as traffic volume. A large carrier such as Air Canada requires a variety of aircraft to suit a variety of applications.



Show the cadets Figure 17I-1.

CONFIRMATION OF TEACHING POINT 2

Participation in the aircraft identification activity at the end of this lesson will serve as the confirmation of TP 2.

Teaching Point 3

Conduct an Activity to Allow the Cadets to Test Their Ability to Identify Aircraft Manufacturers

Time: 5 min

Method: In-Class Activity

ACTIVITY

OBJECTIVE

The objective of this activity is to give the cadets an opportunity to test their ability to identify aircraft manufacturers.

RESOURCES

Pictures of aircraft located at Annexes C to H, with titles blocked out (with sticky notes).

ACTIVITY LAYOUT

N/A.

ACTIVITY INSTRUCTIONS

1. Divide the cadets into two teams on opposite sides of the room.
2. Display a picture of an aircraft discussed during this lesson.
3. Have one team attempt to identify the aircraft and its manufacturer in 10 seconds.
4. Award one point for the aircraft's name and another for the manufacturer.
5. If the first team is unable to name the aircraft or its manufacturer, the second team may try.
6. Award two points for successful aircraft or manufacturer naming by the second team.
7. Alternate the successive pictures and opportunities between the two teams.
8. The team with the most points after five minutes is the winner.

SAFETY

N/A.

CONFIRMATION OF TEACHING POINT 3

Participation in the activity will serve as the confirmation of TP 3.

END OF LESSON CONFIRMATION

Participation in the aircraft identification activity will serve as the confirmation of this lesson.

CONCLUSION

HOMEWORK/READING/PRACTICE

N/A.

METHOD OF EVALUATION

N/A.

CLOSING STATEMENT

Aircraft manufacturers, like their product lines, are constantly changing. To make aircraft that can compete in sophisticated markets, the organizations themselves must improve to meet the ever-evolving competition.

INSTRUCTOR NOTES/REMARKS

The manufacturers and the aircraft included in this lesson were chosen because cadets frequently encounter these aircraft. Time limitations prevented more manufacturers and aircraft from being included.

REFERENCES

- C3-232 Cessna Aircraft Company. (2008). *Welcome to Cessna.com*. Retrieved February 8, 2008, from <http://cessna.com/>.
- C3-233 Diamond Aircraft Industries. (2008). *Diamond Aircraft*. Retrieved February 8, 2008, from <http://www.diamondair.com/mainpage.php>.
- C3-234 Piper Aircraft, Inc. (2008) *Piper: Freedom of Flight*. Retrieved February 8, 2008, from <http://www.newpiper.com/>.
- C3-235 Viking Air. (2008). *Viking*. Retrieved February 8, 2008, from <http://www.vikingair.com/>.
- C3-236 Airbus. (2008). *Airbus*. Retrieved February 8, 2008, from <http://www.airbus.com/en/>.
- C3-237 Boeing. (2008). *Boeing*. Retrieved February 8, 2008, from <http://www.boeing.com/>.

THIS PAGE INTENTIONALLY LEFT BLANK



ROYAL CANADIAN AIR CADETS
PROFICIENCY LEVEL THREE
INSTRUCTIONAL GUIDE



SECTION 3

EO M370.03 – DESCRIBE ROUTINE AIRCRAFT INSPECTION PROCEDURES

Total Time: 30 min

PREPARATION

PRE-LESSON INSTRUCTIONS

Resources needed for the delivery of this lesson are listed in the lesson specification located in A-CR-CCP-803/PG-001, Chapter 4. Specific uses for said resources are identified throughout the instructional guide within the TP for which they are required.

Review the lesson content and become familiar with the material prior to delivering the lesson.

Create a slide of Annex J.

Photocopy handout of Annex J for each cadet.

PRE-LESSON ASSIGNMENT

N/A.

APPROACH

An interactive lecture was chosen for this lesson to orient the cadets to routine aircraft inspections, give an overview of them, and to generate interest.

INTRODUCTION

REVIEW

IAW EO M370.01 (Identify Components of the Pitot Static System, Section 1), the cadet will review the purpose and importance of pitot tubes and static pressure vents.

OBJECTIVES

By the end of this lesson the cadet shall be expected to describe routine aircraft inspection procedures.

IMPORTANCE

It is important for cadets to be able to describe routine aircraft inspection procedures so they may appreciate the attention that must be given to safety in aviation.

Teaching Point 1**Describe the Pilot's Inspection Prior to Flight**

Time: 10 min

Method: Interactive Lecture

An aircraft operating in Canada is subject to inspections that allow the aircraft to operate safely. There are two main types of inspections:

1. inspections performed by the pilot prior to flight, and
2. inspections performed by a certified Aircraft Maintenance Engineer (AME) at designated intervals appropriate to the aircraft.



This inspection overview and all others described in this instructional guide are examples only. Always refer to and follow the recommendations of the manufacturer when carrying out any inspections and procedures. Individual models of aircraft may have special procedures and inspection guidelines that will vary from those described here.

PILOT'S INSPECTION PRIOR TO FLIGHT

Prior to every flight, a pilot completes a thorough inspection of the aircraft.

Overall Appearance of the Aircraft

The pilot stands a short distance away from the aircraft and observes the general overall appearance of the aircraft, looking for obvious defects. This is important because it may indicate large defects that could affect aerodynamics.

Before beginning the walk-around inspection, enter the cockpit and ensure that the aircraft is prepared for inspection, ensuring:

- battery and ignition switches are OFF,
- control locks are REMOVED, and
- landing gear switch is in the gear DOWN position.

Fuselage/Empennage

Inspection of the fuselage/empennage will include:

- baggage compartment: contents properly arranged and secured,
- static air pressure vents: free from obstructions,
- pitot tube: free from obstructions – cover REMOVED,
- conditions of the aircraft covering: missing or loose rivets, cracks, tears, etc.,
- anti-collision and navigation lights: condition,
- avionics antennas: cracks, oil or dirt, proper mounting and damage,
- wheel and tires: cuts, bruises, excessive wear, and proper inflation,
- oleo shock absorber and shock strut: proper inflation and cleanliness,
- wheel well and fairing: general condition and secure,

- limit and position switches: cleanliness and secure, and
- ground safety lock: REMOVED.

Wings

Inspection of the wings will include:

- control surface locks: REMOVED,
- control surfaces: dents, cracks, excess play, condition of hinge pins and bolts,
- covering: missing or loose rivets, cracks, tears, etc,
- wing tip and navigation light: wing tip and light secure and undamaged,
- landing light: condition, cleanliness, secure, and
- stall warning vane: freedom of movement.

Prior to inspection, turn the master switch ON so that the stall warning signal can be checked when the vane is deflected.

Fuel

Inspection of the aircraft fuel systems will include:

- fuel quantity in tank: type and amount of fuel visually checked,
- fuel tank filler cap and fairing covers secure,
- fuel tank vents: clear of obstructions,
- drain valve: free of contaminants (drain fuel into a container to check), and
- drain cocks: operating properly without drips.

Engine/Propeller

Inspection of the engine/propeller will include:

- engine oil quantity: oil sump filled and filler cap and dipstick secured,
- general condition and evidence of fuel and oil leaks,
- cowling, access doors, and cowl flaps: condition checked and all secure,
- carburetor air filter: clean and secure,
- exhaust stacks: no cracks and studs tight,
- spark plugs: terminals secure and clean,
- engine mount: cracks and mounts secure,
- main fuel strainer: free of water or sediment (drain fuel into a container to check),
- cowling and baffle: seals snug and in place for proper engine cooling,
- propeller and spinner: security, oil leakage and condition. No deep nicks or scratches, and
- ground area under the propeller: free of loose stones, cinders, etc.

Instruments Check

Check all instruments for proper reading and, where applicable, fluid levels.

Emergency Locator Transmitter (ELT)

Inspection of the ELT to ensure:

- it is mounted securely,
- tight connections,
- general condition (no corrosion),
- antenna secure,
- annual recertification completed and current,
- battery not time-expired, and
- ELT switch in ARMED position.

Seat Belts

Check that seat belts are secure and in good condition. Secure seat belts in unoccupied seats.

Doors and Windows

Close and secure doors, windows and canopy top.

CONFIRMATION OF TEACHING POINT 1

QUESTIONS

- Q1. When does a pilot perform an inspection of the aircraft?
- Q2. When does an AME perform an inspection of the aircraft?
- Q3. What is an ELT?

ANTICIPATED ANSWERS

- A1. Prior to flight.
- A2. At designated intervals appropriate to the aircraft.
- A3. Emergency Locator Transmitter.

Teaching Point 2

Describe the Pilot's Cockpit Check Prior to Flight

Time: 10 min

Method: Interactive Lecture

PILOT'S COCKPIT CHECK PRIOR TO FLIGHT

A systematic and careful cockpit check will be carried out prior to flight. It is extremely important to carry out a thorough pre-flight inspection. Small clues indicating a malfunctioning or damaged component may easily be missed in a hurried pre-flight check. Be vigilant after maintenance, painting or a modification job has been performed on the airplane. It is possible for components to be reinstalled incorrectly.

Written Checklist for the Specific Aircraft Type

The cockpit check will be made deliberately without haste using a written checklist. A definite sequence will be followed, moving clockwise around the cockpit. Each control will be touched and named aloud. Always work from a written checklist, not a memorized list, no matter how small the aircraft.



Show the cadets the slide of Figure 17J-1.

There are many checklists relating to the various phases in the operation of an aircraft: pre-flight, before starting engines, before taxiing, engine run-up, before takeoff, takeoff and climb, cruise, descent, before landing, aborted landing, after landing and after shutdown, as well as checklists relating to emergency situations. Larger aircraft use them all. Whenever checklists are required for an aircraft, they must be used during all phases of the aircraft's operation to which they apply.

Run-Up of the Engine(s)

Position the aircraft into the wind when running up the engine(s) for engine cooling. Open and close the throttle slowly while checking operation, to include:

- oil pressure and temperature,
- RPM at full throttle,
- magneto operation,
- instruments, to include:
 - voltmeter,
 - ammeter,
 - manifold pressure gauge,
 - fuel pressure gauge,
 - tachometer,
 - vacuum, and
 - other instruments as shown on the written checklist;
- carburetor heat,
- fuel mixture control,
- idling speed,
- working engine temperature, and
- other parameters as shown on the written checklist.

Switches

Check switch positions for takeoff as per written checklist (eg, magneto ON, generator ON, anti-collision beacon ON, navigation lights ON, etc).

Flaps Set for Takeoff

Adjust the flaps to the takeoff position when ready for takeoff.

Control Surface Operation

Check freedom of all controls, to include:

- ailerons,
- elevators, and
- rudders.

While moving the control column and rudder pedals, check that the control surfaces are responding in the proper direction of travel. This check is particularly important if the aircraft has undergone maintenance.

ACTIVITY

Time: 5 min

OBJECTIVE

The objective of this activity is to allow the cadets to experience completing a pilot checklist.

RESOURCES

Photocopies of Annex J for each cadet.

ACTIVITY LAYOUT

N/A.

ACTIVITY INSTRUCTIONS

1. Give each cadet a photocopy of Figure 17J-1.
2. Divide the cadets into pairs.
3. Have one cadet, acting as pilot in command (PIC), call out the checklist steps for Pre-flight Inspection Cockpit.
4. Have the second cadet, acting as co-pilot, repeat commands and act out the procedure in any manner that the PIC deems appropriate.
5. Have the cadets trade roles and have the new PIC call out the checklist steps for Before Takeoff.
6. Have the new co-pilot repeat commands and act out the procedure.

SAFETY

N/A.

CONFIRMATION OF TEACHING POINT 2

QUESTIONS

- Q1. What is used to guide a cockpit check?

- Q2. Why is it important to be vigilant after maintenance, painting or a modification job has been performed on the airplane?
- Q3. Why position the aircraft into the wind when running up the engine(s)?

ANTICIPATED ANSWERS

- A1. A written checklist.
- A2. It is possible for components to be reinstalled incorrectly.
- A3. For engine cooling.

Teaching Point 3

Discuss an Aircraft's Required Inspections

Time: 5 min

Method: Interactive Lecture

AN AIRCRAFT'S REQUIRED INSPECTIONS

Certificate of Airworthiness (C of A)

A Transport Canada (TC) C of A can be issued for an aircraft, which fully complies with all standards of airworthiness certification (for its applicable type).



TC regulations require that an aircraft carry its C of A on every flight.

Annual Airworthiness Information Report (AAIR)

The owner of a Canadian aircraft, other than an ultralight aeroplane, must submit an AAIR using the prescribed report form. The aircraft owner will complete the annual report by entering all data required and signing the certification to vouch that the information supplied is correct.

Approved Maintenance Schedules

All Canadian aircraft, other than ultralight or hang gliders, shall be maintained in accordance with an approved maintenance schedule, approved by the Minister of Transport, which meets the Aircraft Equipment and Maintenance Standard.

Approved maintenance schedules shall:

- be based upon data obtained from an approved maintenance review board (MRB) report; or
- where no current MRB report exists, be based upon data obtained from:
 - the current recommendations of the aircraft manufacturer,
 - a maintenance schedule approved by the Minister for use by another operator, or
 - any other data acceptable to the Minister.

CONFIRMATION OF TEACHING POINT 3

QUESTIONS

- Q1. When can a C of A be issued?

Q2. How often must an AAIR be submitted?

Q3. Who approves a maintenance schedule?

ANTICIPATED ANSWERS

A1. When an aircraft fully complies with all standards of airworthiness certification (for its applicable type).

A2. Annually.

A3. The Minister of Transport.

END OF LESSON CONFIRMATION

QUESTIONS

Q1. When does a pilot perform an inspection of the aircraft?

Q2. What is used to guide a cockpit check?

Q3. What requires an aircraft to carry its C of A on every flight?

ANTICIPATED ANSWERS

A1. Prior to flight.

A2. A written checklist.

A3. TC regulations.

CONCLUSION

HOMEWORK/READING/PRACTICE

N/A.

METHOD OF EVALUATION

N/A.

CLOSING STATEMENT

Safety in aviation requires attention to detail and it can only be successful through careful planning and preparation.

INSTRUCTOR NOTES/REMARKS

N/A.

REFERENCES

C3-116 (ISBN 0-9680390-5-7) MacDonald, A. F., & Peppler, I. L. (2000). *From the Ground Up: Millennium edition*. Ottawa, ON: Aviation Publishers Co. Limited.



ROYAL CANADIAN AIR CADETS
PROFICIENCY LEVEL THREE
INSTRUCTIONAL GUIDE



SECTION 4

EO C370.01 – IDENTIFY TASKS REQUIRED TO MAINTAIN AIRCRAFT

Total Time: 30 min

PREPARATION

PRE-LESSON INSTRUCTIONS

Resources needed for the delivery of this lesson are listed in the lesson specification located in A-CR-CCP-803/PG-001, Chapter 4. Specific uses for said resources are identified throughout the instructional guide within the TP for which they are required.

Review the lesson content and become familiar with the material prior to delivering the lesson.

Photocopy handouts located at Annexes K to M for each cadet.

PRE-LESSON ASSIGNMENT

N/A.

APPROACH

An interactive lecture was chosen for this lesson to review, clarify, emphasize and summarize the tasks required to maintain aircraft.

INTRODUCTION

REVIEW

N/A.

OBJECTIVES

By the end of this lesson the cadet shall have identified tasks required to maintain aircraft.

IMPORTANCE

It is important for cadets to identify tasks required to maintain aircraft so that they will have an appreciation for the aircraft maintenance industry, including an understanding of safety requirements.

Teaching Point 1

Discuss Aircraft Maintenance Work

Time: 10 min

Method: Interactive Lecture

During the early days of aviation it was discovered that flying posed safety hazards. As aviation matured, organizations were formed to develop and enforce safety procedures. Faster aircraft and increasing air traffic became essential parts of Canadian commerce and industry. Air regulations have developed to keep pace with

technological and social changes. Each regulation has a purpose and was put in place with the intention of supporting safe aviation.

MAINTENANCE CERTIFICATION

Aircraft maintenance in Canada is regulated by the Canadian Aviation Regulations (CARs). CARs are a compilation of regulatory requirements designed to enhance both safety and the competitiveness of the Canadian aviation industry. Parts I–VIII of the CARs correspond to eight broad areas of aviation:

- Part I – General Provisions,
- Part II – Aircraft Identification and Registration,
- Part III – Aerodromes, Airports and Heliports,
- Part IV – Personnel Licensing and Training,
- Part V – Airworthiness,
- Part VI – General Operating and Flight Rules,
- Part VII – Commercial Air Services, and
- Part VIII – Air Navigation Services.

EXAMPLES OF MAINTENANCE REQUIRING CERTIFICATION

CARs Part V – Airworthiness and Part VI – General Operating and Flight Rules, include the regulations for aircraft maintenance and elementary work. Generally, maintenance done on an aircraft in Canada must be followed by a maintenance release signed by a licensed aircraft maintenance engineer (AME) before the aircraft can be flown. Certain routine tasks have been designated as elementary work and do not require an AME’s signature. Instead, the aircraft owner or appointee must record the work done in the aircraft’s technical record, such as the journey logbook and technical logbooks.

A maintenance release signed by an AME is required for activities such as:

- modifying, repairing or replacing structural airframe parts;
- overhauling the engine;
- re-contouring or straightening a propeller blade;
- repairing avionics; and
- welding fuel tanks.

CONFIRMATION OF TEACHING POINT 1

QUESTIONS

- Q1. What does the acronym CARs mean in Canadian aviation?
- Q2. What does the acronym AME mean in Canadian aviation?
- Q3. Who must sign a maintenance release?

ANTICIPATED ANSWERS

- A1. Canadian Aviation Regulations.

A2. Aircraft Maintenance Engineer.

A3. An AME.

Teaching Point 2

Discuss Elementary Work

Time: 15 min

Method: Individual Activity

Although performing and recording elementary work is less restrictive by aviation standards, it is still very rigorous by typical standards in such fields as private automobile maintenance. To understand aviation maintenance, cadets must recognize the difference between flying at hundreds of km/h at thousands of feet above the ground and parking a stalled car on the shoulder of the road when a fan belt breaks.

SPECIFIC TASKS DESIGNATED AS ELEMENTARY WORK

The difference between maintenance requiring a maintenance release and elementary work has been made easy to recognize in CAR Part VI, Standard 625, Appendix A—Elementary Work.

Elementary work task listings include 29 specific items that cover many routine activities including, under specified circumstances, changing engine oil, changing spark plugs, removing and replacing glider wings and tail surfaces, checking and replacing batteries, changing light bulbs, repairing upholstery, etc.



Distribute a copy of Annex K to each cadet.



The CARs carefully limit the activities in elementary work. For example, checking tire pressures over 100 psi is not elementary work and will require a maintenance release.

RECORDING ELEMENTARY WORK

Elementary work performed on light aircraft is recorded in the aircraft's technical record. The entry in the technical record of the work performed must be signed by the person who performed the work. Since aviation maintenance is a safety consideration, the accurate recording of all maintenance is important. Aircraft logbooks are often the first documents to be collected by investigators in the event of an accident.



Transport Canada (TC) regulations stipulate that all maintenance must be logged before the aircraft is flown.



Distribute Annexes L and M to each cadet.

ACTIVITY

Time: 5 min

OBJECTIVE

The objective of this activity is to familiarize the cadets with recording elementary work.

RESOURCES

Handouts of Annexes L and M.

ACTIVITY LAYOUT

N/A.

ACTIVITY INSTRUCTIONS

1. Demonstrate how to fill out the logbook pages as per the examples located at Annex M.
2. Have each cadet fill in the top line of their blank journey logbook flight record at Annex L to show a fictitious flight from CNT7 (Picton, Ont.) to CYSN (Welland, Ont.), establishing a history for an imaginary aircraft. Except for the date, the details of that data line should look similar to the 26 Aug 07 data line entered by M. Calvert and shown at Annex M.
3. Upon arrival at Welland, have each cadet record the addition of a litre of engine oil and adjustment of tire pressure in their logbook pages, as well as two other items of elementary work selected from the list located at Annex K.
4. If cadets do not complete all this work in the time, have them complete it after class. Ensure that the flight details and the engine oil addition are recorded correctly.

SAFETY

N/A.

CONFIRMATION OF TEACHING POINT 2

The cadets' participation in the activity will serve as the confirmation of this TP.

END OF LESSON CONFIRMATION

QUESTIONS

- Q1. Who must sign a maintenance release?
- Q2. What tasks may be performed on an aircraft without a maintenance release?
- Q3. How many specific tasks has TC designated as elementary work?

ANTICIPATED ANSWERS

- A1. An AME.
- A2. Tasks designated as elementary work by the TC CARs.
- A3. 29.

CONCLUSION

HOMEWORK/READING/PRACTICE

N/A.

METHOD OF EVALUATION

N/A.

CLOSING STATEMENT

Aircraft maintenance is a critical part of aviation and of Canadian transportation, commerce and industry. Professionally performed, aircraft maintenance serves the requirements of both safety and efficiency.

INSTRUCTOR NOTES/REMARKS

N/A.

REFERENCES

- C3-096 (ISBN 1715-7382) Transport Canada. (2006). *Aeronautical Information Manual*. Ottawa, ON: Her Majesty the Queen in Right of Canada.
- C3-210 (ISBN 0-660-62327-7) Transport Canada. (2003). *Aircraft Journey Log*. Ottawa, ON: Her Majesty the Queen in Right of Canada.
- C3-211 (ISBN 0-660-19017-6) Transport Canada. (2005). *Airframe Log*. Ottawa, ON.

THIS PAGE INTENTIONALLY LEFT BLANK



ROYAL CANADIAN AIR CADETS
PROFICIENCY LEVEL THREE
INSTRUCTIONAL GUIDE



SECTION 5

EO C370.02 – DESCRIBE MATERIALS USED IN AIRCRAFT CONSTRUCTION

Total Time: 30 min

PREPARATION

PRE-LESSON INSTRUCTIONS

Resources needed for the delivery of this lesson are listed in the lesson specification located in A-CR-CCP-803/PG-001, Chapter 4. Specific uses for said resources are identified throughout the instructional guide within the TP for which they are required.

Review the lesson content and become familiar with the material prior to delivering the lesson.

Create slides of figures located at Annexes N to P.

PRE-LESSON ASSIGNMENT

N/A.

APPROACH

An interactive lecture was chosen for this lesson to review, clarify, emphasize and summarize materials used in aircraft construction.

INTRODUCTION

REVIEW

N/A.

OBJECTIVES

By the end of this lesson the cadet shall be expected to describe materials used in aircraft construction.

IMPORTANCE

It is important for cadets to learn about materials used in aircraft construction as it will enhance their understanding of the materials used to build aircraft and why they are chosen.

Teaching Point 1**Describe Wood and Fabrics Used in Aircraft Construction**

Time: 5 min

Method: Interactive Lecture

WOOD

Although wood was used for the first airplanes because of its high strength and low weight, the cost of manpower needed for wood construction and maintenance has caused wood to be almost entirely replaced by other materials, particularly metal.

Species of Wood

If wood is used, it must be carefully selected to meet aviation requirements. Aircraft grade Sitka spruce, sometimes referred to as Airplane spruce, is the preferred reference wood for aviation because of its uniformity, strength and shock-resistance.

Assessment of Wood

If other wood is substituted for aircraft grade Sitka spruce, the replacement wood must meet the same requirements.

Laminated wood is constructed of two or more layers of wood that are bonded together with a glue or resin.

Assessing wood requires the examination of many characteristics such as grain, knots and pitch pockets. A defect might make a piece of wood unusable.

FABRIC**Organic Fabric**

Early aircraft were constructed using organic fabrics, such as linen, for the skin of the fuselage and wings. The earliest builders did not use any process to increase the strength of the material. The material was not airtight and it loosened and wrinkled with changes in humidity. Soon, rubberized and varnished coatings came into use to improve the fabric. Later, cotton fibres dissolved in nitric acid were used to make a dope that was worked into the fabric to produce a more durable finish.



Show the cadets the Black Maria, an example of fabric construction, at Annex N.



The Black Maria can be seen today in the National Aviation Museum in Ottawa, ON.

The next step in fabric improvement was to paint enamel over the doped fabric. It cracked and peeled with time, so aluminum powder was blended into the paint. The aluminum powder pigmentation proved very effective in blocking harmful sunlight and reflecting heat away from the fabric.

Other improvements in doping followed, but eventually advances in chemical technology led to new finishes on durable synthetic materials. Although various high grades of cotton are still sometimes used, man-made inorganic fabrics have become the most popular fabric for covering an aircraft.

Inorganic Fabric

Polyester fibres, woven into cloth with different weights are sold under various trade names. Other inorganic fibres include fibreglass and composites.

CONFIRMATION OF TEACHING POINT 1

QUESTIONS

- Q1. Why has wood been used less for modern aircraft?
 Q2. What species is the preferred reference wood for aircraft construction?
 Q3. What is laminated wood?

ANTICIPATED ANSWERS

- A1. Wood construction has high costs for manpower.
 A2. The reference species is Sitka spruce.
 A3. Laminated wood is constructed of two or more layers of wood that are bonded together with a glue or resin.

Teaching Point 2

Describe Composites Used in Aircraft Construction

Time: 15 min

Method: Interactive Lecture

COMPOSITE CONSTRUCTION



The term composite in this lesson refers to a combination of two or more materials that differ in composition or form. Composite is sometimes used to mean any synthetic building material.

Composite structures differ from metallic structures in important ways: excellent elastic properties, high strength combined with light weight and the ability to be customized in strength and stiffness. The fundamental nature of many composites comes from the characteristics of a strong fibre cloth imbedded in a resin.

Fibreglass

Fibreglass is made from strands of silica glass that are spun together and woven into cloth. Fibreglass weighs more and has less strength than most other composite fibres. However, improved matrix materials now allow fibreglass to be used in advanced composite aviation applications.



A matrix is any material that sticks other materials together.

There are different types of glass used in fibreglass: E-glass, which has a high resistance to electric current, and S-glass, which has a higher tensile strength, meaning that the fabric made from it resists tearing.

Aramid

Aramid is a polymer. A polymer is composed of one or more large molecules that are formed from repeated units of smaller molecules.



Ask the cadets to name all the applications they are aware of for Kevlar® .

The best-known aramid material is Kevlar®, which has a tensile strength approximately four times greater than the best aluminum alloy. This cloth material is used in many applications where great strength is needed: canoes, body armour and helicopter rotors. Aramid is ideal for aircraft parts that are subject to high stress and vibration. The aramid's flexibility allows it to twist and bend in flight, absorbing much of the stress. In contrast, a metal aircraft part would develop fatigue and stress cracks sooner under the same conditions.

Carbon/Graphite

The term carbon is often used interchangeably with the term graphite; however, they are not quite the same material. Carbon fibres are formed at 1315 degrees Celsius (2400 degrees Fahrenheit), but graphite fibres are produced only above 1900 degrees Celsius (3450 degrees Fahrenheit). As well, their actual carbon content differs – but both carbon and graphite materials have high compressive strength and stiffness.

Carbon molecules will form long strings that are extremely tough (this is what makes diamonds so strong). These minute hair-like strands of carbon (a very common and inexpensive element) are, per unit of weight, many times stronger than steel. Individual carbon fibres are flexible, rather than stiff, and bend easily despite having high tensile strength. To stiffen the fibres, cross-directional layers are immersed in a matrix material such as epoxy plastic.



The term epoxy refers to a substance derived from an epoxide. An epoxide is a carbon compound containing an oxygen atom bonded in a triangular arrangement to two carbon atoms. So, an epoxy matrix is itself carbon-based, as are the fibres that it binds.



Show the cadets Figure 17O-1.

The passenger cabin of airliners must be pressurized so that passengers will not have to wear oxygen masks during flight. The large two-level cabin of the A380 Airbus requires a bulkhead (wall) to keep this pressurized air from leaking into the unpressurized tail section. Airbus' facility in Stade, Germany specializes in the design and production of carbon fibre reinforced plastic (CFRP) components and the A380 rear pressure bulkhead was produced there.

Ceramic

Ceramic fibre is a form of glass fibre designed for use in high temperature applications. It can withstand temperatures approaching 1650 degrees Celsius (3000 degrees Fahrenheit), making it effective for use around engines and exhaust systems.



Show the cadets Figure 17O-2.

Ceramic's disadvantages include both weight and expense, but sometimes no other known material will do the job. One of the most famous applications of ceramic is the Thermal Protection System used on the space shuttle. The properties of aluminum demand that the maximum temperature of the shuttle's structure be kept below 175 degrees Celsius (350 degrees Fahrenheit) during operations. Heating during re-entry (in other words, heating caused by friction with the air) creates surface temperatures high above this level and in many places will push the temperature well above the melting point of aluminum (660 degrees Celsius or 1220 degrees Fahrenheit).



Underneath its protective layer of tiles and other materials, the space shuttle has an ordinary aluminum construction, similar to many large aircraft.



Show the cadets Figure 17O-3.

A space shuttle's Thermal Protection System is very complex and it contains highly sophisticated materials. Thousands of tiles of various sizes and shapes cover a large percentage of the space shuttle's exterior surface. There are two main types of silica ceramic tiles used on the space shuttle:

- **Low-Temperature Reusable Surface Insulation (LRSI).** LRSI tiles cover relatively low-temperature areas of one of the shuttles, the Columbia, where the maximum surface temperature runs between 370 and 650 degrees Celsius (700 and 1200 degrees Fahrenheit), primarily on the upper surface of fuselage around the cockpit. These tiles have a white ceramic coating that reflects solar radiation while in space, keeping the Columbia cool.



Show the cadets Figure 17O-4.

- **High-Temperature Reusable Surface Insulation (HRSI).** HRSI tiles cover areas where the maximum surface temperature runs between 650 and 1260 degrees Celsius (1200 and 2300 degrees Fahrenheit). They have a black ceramic coating, which helps them radiate heat during re-entry.

Both LRSI and HRSI tiles are manufactured from the same material and their primary difference is the coating.

A different and even more sophisticated material, Reinforced Carbon-Carbon (RCC), is used for the nose cone and leading edges of the space shuttle. It is a composite material consisting of carbon fibre reinforcement in a matrix of graphite, often with a silicon carbide coating to prevent oxidation.

CONFIRMATION OF TEACHING POINT 2

QUESTIONS

- Q1. What type of glass is used in fibreglass strands?
- Q2. What is best known aramid material?
- Q3. What method is used to stiffen carbon fibre materials?

ANTICIPATED ANSWERS

- A1. Silica glass.
- A2. Kevlar®.
- A3. Immersing cross-directional layers of carbon fibres in a matrix compound such as epoxy plastic.

Teaching Point 3**Describe Metals Used in Aircraft Construction**

Time: 5 min

Method: Interactive Lecture

METALS USED IN AIRCRAFT CONSTRUCTION**Aluminum**

Pure aluminum lacks sufficient strength to be used for aircraft construction. However, its strength increases considerably when it is alloyed or mixed with other compatible metals. For example, when aluminum is mixed with copper or zinc, the resultant aluminum alloy is as strong as steel, with only one-third the weight. As well, the corrosion resistance possessed by the aluminum carries over to the newly formed alloy.

Alclad®

Most external aircraft surfaces are made of clad aluminum. Alclad® consists of a pure aluminum coating rolled onto the surface of heat-treated aluminum alloy. The thickness of the aluminum coating is approximately five percent of the alloy thickness, on each side of the alloy sheet. This clad surface greatly increases the corrosion resistance of the aluminum alloy. However, if the aluminum coating is penetrated, corrosion can attack the alloy within.

Magnesium

Magnesium is one of the lightest metals with sufficient strength and suitable working characteristics for use in aircraft structures. In its pure form it lacks sufficient strength, but like aluminum, mixing it with other metals to create an alloy produces strength characteristics that make magnesium useful.

Titanium

Titanium and its alloys are lightweight metals with very high strength. Pure titanium weighs only half as much as stainless steel and is soft and ductile. Titanium's alloys have excellent corrosion resistance, particularly to salt water.



Show the cadets Figure 17P-1 and Figure 17P-2.

Stainless Steel

Stainless steel is a classification of corrosion-resistant steel that contain large amounts of chromium and nickel. It is well suited to high-temperature applications such as firewalls and exhaust system components.

CONFIRMATION OF TEACHING POINT 3

QUESTIONS

- Q1. Why is pure aluminum unsuitable for use in aircraft components?
- Q2. What three characteristics make titanium useful for aircraft components?
- Q3. What two metals are mixed with steel to make stainless steel?

ANTICIPATED ANSWERS

- A1. Pure aluminum lacks sufficient strength.
- A2. Titanium alloys have high strength, are lightweight and are resistant to corrosion.
- A3. Steel is mixed with chromium and nickel.

END OF LESSON CONFIRMATION

QUESTIONS

- Q1. What species is the reference wood for aircraft construction?
- Q2. What is the name used to commonly identify aramid material?
- Q3. What two metals are mixed with steel to make stainless steel?

ANTICIPATED ANSWERS

- A1. The reference wood is Sitka spruce.
- A2. Aramid is commonly called Kevlar®.
- A3. Steel is mixed with chromium and nickel.

CONCLUSION

HOMEWORK/READING/PRACTICE

N/A.

METHOD OF EVALUATION

N/A.

CLOSING STATEMENT

Materials used in aircraft construction have evolved and improved since the earliest construction and the rate of change is accelerating. Advances in associated technologies are continually integrated with aircraft construction as aircraft become larger, more powerful and more complex.

INSTRUCTOR NOTES/REMARKS

N/A.

REFERENCES

- C3-136 (ISBN 0-88487-207-6) Sanderson Training Systems. (2001). *A&P Technician Airframe Textbook*. Englewood, CO: Jeppesen Sanderson Inc.



ROYAL CANADIAN AIR CADETS
PROFICIENCY LEVEL THREE
INSTRUCTIONAL GUIDE



SECTION 6

**EO C370.03 – IDENTIFY BASIC POWER TOOLS USED
 IN AIRCRAFT MANUFACTURING AND MAINTENANCE**

Total Time:

30 min

PREPARATION

PRE-LESSON INSTRUCTIONS

Resources needed for the delivery of this lesson are listed in the lesson specification located in A-CR-CCP-803/PG-001, Chapter 4. Specific uses for said resources are identified throughout the instructional guide within the TP for which they are required.

Review the lesson content and become familiar with the material prior to delivering the lesson.

Create slides of figures located at Annexes Q to S.

PRE-LESSON ASSIGNMENT

N/A.

APPROACH

An interactive lecture was chosen for TPs 1–3 to identify basic power tools used in aircraft manufacturing and maintenance and to give an overview of them.

An in-class activity was chosen for TP 4 as it is an interactive way to confirm the cadets' comprehension of the material.

INTRODUCTION

REVIEW

N/A.

OBJECTIVES

By the end of this lesson the cadet will have identified basic power tools used in aircraft manufacturing and maintenance.

IMPORTANCE

It is important for the cadets to know about basic power tools used in aircraft manufacturing and maintenance because this will enhance their knowledge of aircraft construction and the aviation maintenance field.

Teaching Point 1**Describe the Characteristics and Methods of Application for Power Hand Tools Used With Aircraft**

Time: 5 min

Method: Interactive Lecture

POWER HAND TOOLS

Power hand tools were originally developed to speed up work. However, some hand tools have improved to the point that they allow a novice to produce a degree of precision and excellence that was previously only attainable by expert master craftsmen.

Power hand tools also create safety concerns. Their power allows them to do a lot of damage in a very short time and their power also makes them hard to control. A twisting or reciprocating power tool can easily cause the user to lose their balance when it is first applied to the work piece. This loss of balance can result in damage to the work piece and injuries to the worker.



Show the cadets the slide of each tool at Annex Q, as they are discussed.

Drill. If there were no restrictions on technician's space or movement, there would only need to be one type of drill. However, when working in and around aircraft, drill requirements become more complex, which has given rise to various types and shapes of drills, to include:

- electric,
- pneumatic,
- right angle,
- flexible drive right angle,
- flexible drive straight, and
- long drill bit.

The drills in Figure 17Q-1 look like dentists' tools because the functions are similar. Aircraft construction and maintenance has very confined, hard-to-reach spaces that need to be worked on and worked in.

Electric hand drills can perform a number of tasks. They can drill small round holes using drill bits and they can drill large round holes using hole saw bits. There are many specialty attachments, such as screwdriver bits and sanding disks.

Reciprocating Saw. A reciprocating saw is used to make rough cuts. Reciprocating saw blades are easily replaced. They come in a variety of grades for different materials and cutting speeds. When blades are worn, they are recycled appropriately and replaced.

Sander. A disk sander is used to trim curved cuts in sheet metal, wood or plastic after they have been rough cut. Disks for sanders are easily replaced and they come in a variety of grades and materials for different applications. When worn they are discarded.

CONFIRMATION OF TEACHING POINT 1

QUESTIONS

- Q1. Why are there many different styles of drills?
- Q2. What is a reciprocating saw used for?
- Q3. What materials can a disk sander be used for?

ANTICIPATED ANSWERS

- A1. Drills have to be used in confined, hard-to-reach spaces.
- A2. It is used to make rough cuts.
- A3. A disk sander can be used on metal, wood or plastic.

Teaching Point 2

Describe the Characteristics and Methods of Application for Shop Equipment Used With Aircraft

Time: 5 min

Method: Interactive Lecture

Aircraft are characterized by smooth curved and rounded streamlined shapes intended to reduce turbulence and drag. To form the skin of the aircraft into these shapes, sheet metals must be formed very carefully. A number of tools have developed, which allow fast, accurate metal cutting and forming.



Sheet metal gauges are numbered so that the thicker materials have lower designation numbers. Therefore, 12 gauge metals are thicker than 24 gauge metals.



Show the cadets the slide of each tool at Annex R, as they are discussed.

FORMING TOOLS

Bar Folding Machine. A bar folding machine is used to bend the edges of relatively light sheet metal stock, up to 22 gauge thickness.

Cornice Brake. Cornice brakes, or leaf brakes as they are sometimes called, are used for bending sheet metal of a wide range of thicknesses, including heavier materials up to 12 gauge.

Slip Roll Former. A slip roll former is used to make gentle bends and to fabricate parts such as contoured fuselage skin.

COMPOUND CURVE TOOLS

Mechanical Compound Curve Tools. Large volumes of smaller compound curve components can be fabricated in a hydropress, which uses a rubber blanket and water pressure to form the component from a carefully shaped die.

Manual Compound Curve Tools. Sandbags and hammers are often used when only one compound curve component is to be formed.

CUTTING TOOLS

Squaring Shear. A squaring shear is used to make straight cuts across sheet metal.

Scroll Shear. Scroll shears are used to make irregular cuts on the inside of a sheet of metal without cutting through to the edge.

Band Saw. A band saw is used for cutting curved lines in metal, wood or plastic. The blade speed can be varied for each material.

Drill Press. A drill press is used to increase accuracy and straightness beyond what a hand-held drill can accomplish.

Lathe. A lathe is used for spinning objects so that they can be cut into a circular shape. A lathe makes circular objects in the way that a drill press makes circular holes.

Rotary Punch Press. A rotary punch press is used to punch holes or make circular cuts in metal parts.

CONFIRMATION OF TEACHING POINT 2

QUESTIONS

- Q1. What are scroll shears used for?
- Q2. What is another name for a cornice break?
- Q3. What are two tools used to make components with compound curves?

ANTICIPATED ANSWERS

- A1. Scroll shears are used to make irregular cuts on the inside of a sheet of metal without cutting through to the edge.
- A2. A cornice break is also called a leaf break.
- A3. A hydropress or a sandbag and hammer can be used for compound curves.

Teaching Point 3

Describe the Characteristics and Methods of Application for Fastening Tools and Associated Fasteners Used With Aircraft

Time: 5 min

Method: Interactive Lecture



Show the cadets the slide of each tool at Annex S, as they are discussed.

FASTENING TOOLS

Rivet Gun. Most rivets in aircraft construction are driven by a rivet gun. This is because a rivet gun is fast and can get into tight spaces. However, a rivet gun does less perfect riveting than a compression riveting tool.

Lighter rivet guns are used for placing rivets with small diameter shanks and heavier rivet guns are used for rivets with large shanks.

Rivet Cutter. Rivet cutters have holes for common-size rivet shank diameters. If a rivet is too long for the intended application, the rivet cutter is used to shorten the shank length. To reduce stocking requirements, some shops only stock rivets with long shanks and then cut them to the desired length. A rivet cutter has holes for common shank diameters and leaves that can be selected for the desired shank length.

Bucking Bar. Bucking bars are placed against the opposite end of the rivet from the rivet gun or hammer during the riveting operation. The rivet is flattened between the bucking bar and the hammer or rivet gun. The bucking bar gets its name from the way it bucks, or jumps, on the end of the rivet. There are many shapes and sizes of bucking bars and one of the important challenges of this work begins with the careful selection of the correct bucking bar. It must clear the structure and yet fit perfectly squarely on the end of the rivet.

Squeezer. A squeezer, or compression riveter, is used in place of a rivet gun or hammer. The squeezer is fast and produces a more uniform riveting shape than either hammers or rivet guns, but a squeezer can only operate on easily accessible locations near the edge of the material.

ASSOCIATED FASTENERS

Rivet. Rivets have been used since sheet metal was first used in aircraft construction and they remain the single most common aircraft fastener. Rivets change in dimension to fill their hole during riveting. This makes for a very solid attachment. The rivet part number designation conveys much information, including the style of rivet head, the material it is made from, the shank diameter and the shank length.

CONFIRMATION OF TEACHING POINT 3

QUESTIONS

- Q1. What tool places most aircraft rivets?
- Q2. What tool is fastest and produces the best rivet shapes?
- Q3. How did the bucking bar get its name?

ANTICIPATED ANSWERS

- A1. The rivet gun.
- A2. The compression riveting tool, sometimes referred to as a squeezer.
- A3. Bucking bars are called that because of the way they buck, or jump, during riveting.

Teaching Point 4

Conduct a Tool Identification Activity

Time: 10 min

Method: In-Class Activity

ACTIVITY

OBJECTIVE

The objective of this activity is to give the cadets an opportunity to test their knowledge of basic power tools used in aircraft manufacturing and maintenance.

RESOURCES

Pictures of shop tools located at Annexes Q to S, with titles blocked out (with sticky notes).

ACTIVITY LAYOUT

N/A.

ACTIVITY INSTRUCTIONS

1. Divide the cadets into two teams on opposite sides of the room.
2. Display a picture of a shop tool.
3. Have one team attempt to identify the tool and its use in 10 seconds.
4. Award one point for the tool's name and another for the tool's use.
5. If the first team is unable to name the tool or its use, offer an opportunity to the second team.
6. Award two points for successful tool or application naming by the second team.
7. Alternate the successive pictures and opportunities between the two teams.
8. The team with the most points after 10 minutes is the winner.

SAFETY

N/A.

CONFIRMATION OF TEACHING POINT 4

The cadets' participation in the activity will serve as the confirmation of this TP.

END OF LESSON CONFIRMATION

The cadets' participation in the tool identification activity will serve as the confirmation of this lesson.

CONCLUSION

HOMEWORK/READING/PRACTICE

N/A.

METHOD OF EVALUATION

N/A.

CLOSING STATEMENT

Tools and equipment used in aircraft manufacturing and maintenance have developed over the years to increase the speed of the work to be done and to allow a more consistent product. The variety of these tools presents both a challenge and an opportunity to aviation technicians.

INSTRUCTOR NOTES/REMARKS

N/A.

REFERENCES

- C3-136 (ISBN 0-88487-207-6) Sanderson Training Systems. (2001). *A&P Technician Airframe Textbook*. Englewood, CO: Jeppesen Sanderson Inc.
- C3-137 (ISBN 0-88487-203-3) Sanderson Training Systems. (2000). *A&P Technician General Textbook*. Englewood, CO: Jeppesen Sanderson Inc.

THIS PAGE INTENTIONALLY LEFT BLANK



ROYAL CANADIAN AIR CADETS
PROFICIENCY LEVEL THREE
INSTRUCTIONAL GUIDE



SECTION 7

EO C370.04 – CONSTRUCT AN ALUMINUM MODEL BIPLANE

Total Time:	360 min
-------------	---------

PREPARATION

PRE-LESSON INSTRUCTIONS

Resources needed for the delivery of this lesson are listed in the lesson specification located in A-CR-CCP-803/PG-001, Chapter 4. Specific uses for said resources are identified throughout the instructional guide within the TP for which they are required.

Review the lesson content and become familiar with the material prior to delivering the lesson.

View reference C3-160 *Building the B.C. Air Originals Biplane* DVD.

Photocopy all templates and construct one set of wood jigs and wood templates located at Annex T for the cadets. Make Mylar templates of Figures 17T-1 and 17T-2. Using these templates and wood jigs, create parts for two aluminum model biplanes.

Assemble one aluminum model biplane for demonstration purposes, as shown at Annex AG.

Assemble one part for each assembly line.

Photocopy assembly line instructions at Annexes U to AF for each assembly line.

Photocopy one set of final assembly plans at Annex AG for each cadet.

Set up the classroom for the first set of assembly lines outlined in TP 1.

The workstations using power tools for cutting and tapering wood require supervisors.

PRE-LESSON ASSIGNMENT

N/A.

APPROACH

A practical activity was chosen for this lesson as it is an interactive way to introduce cadets to aluminum model biplane construction in a safe, controlled environment. This activity contributes to the development of these skills and knowledge in a fun and challenging setting.

INTRODUCTION

REVIEW

N/A.

OBJECTIVES

By the end of this lesson the cadet shall have constructed an aluminum model biplane.

IMPORTANCE

It is important for cadets to construct an aluminum model biplane because it will allow them to learn about mass production. The aircraft manufacturing industry employs precision mass production techniques to produce modern aircraft.

Teaching Point 1

Explain and Prepare Mass Production of Aluminum Model Biplane Parts

Time: 70 min

Method: Practical Activity

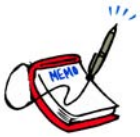

Show the cadets a completed aluminum model biplane.

At the beginning of the 20th century, vehicles were produced one at a time in a manner that today would be called customized. An American named Ransome Eli Olds applied the idea of an assembly line to produce his 1901 Curved Dash Oldsmobile in greater numbers. Henry Ford then improved the assembly line so that his 1914 Model T Ford was assembled in 93 minutes, thus making it possible for the majority of people to afford an automobile.

The Wright brother's 1903 Flyer was produced in a customized manner as well, but Olds' methods were soon applied to aeronautical manufacture when the Wright Aircraft Company was formed in Dayton, Ohio in 1909. Although the mass market for aircraft was slower to grow than the market for automobiles, World War I prompted the United States government to order thousands of aircraft.

Mass production is not limited to large assemblies. It can also be applied to production of models.



Production of parts for the aluminum model biplane will be carried out using a simple assembly line. However, final assembly will be by customization so that each cadet can make a unique model using mass-produced parts.



Show the cadets the parts needed for one aluminum model biplane as well as the templates, tools and raw materials that will be used in mass production.



This EO is intended to introduce the cadets to the methods of mass production. All the parts for the aluminum model biplane will be fabricated by cadets working in assembly lines. However, this cannot be one big assembly line. There are more than 30 pieces, but because each part is very simple, the assembly lines are small and also simple. Some parts must be fabricated first, since other assemblies require them. To begin the process, start as many of the following 13 assembly lines as resources permit, providing work for each cadet:

- raw aluminum material assembly line (described at Annex U),
- wood assembly line (Annex V),
- aluminum billet assembly line (Annex W),
- aluminum panel shearing assembly line (Annex X) using billets from the previous line,
- cardboard insert assembly line (Annex Y),
- wire station assembly line (Annex Z), and
- drill station assembly line for bottle caps (Annex AA).

As soon as these assembly lines have produced materials for stock, the fuselage assembly line, the top wing assembly line, the empennage assembly line and the propeller assembly line can be formed to begin those processes.

Except for certain assembly lines, such as the Wood Assembly Line and the Drill Assembly Line, the cadets will be seated at their tables or desks within proximity of each other so that materials can be passed on for processing. For example, once a cadet with the template has marked an aluminum billet with the shape of the horizontal stabilizer, the billet must be passed on to the next cadet with scissors to be cut out. This is also the case with cardboard inserts. All such work takes place at a desk or table.



Beyond the initial start-up phase, timings for other assembly lines cannot be predicted since this depends on the speed at which individual lines work and the parts for aluminum model biplanes are made. As well, additional manpower may have to be provided for assembly lines that cannot keep up; any cadet can do this work but some cadets will be faster than others. The instructor is expected to balance manpower as work progresses.

To allow for spare parts, an additional 10 per cent of parts should be made above the amounts required. This is due to inevitable losses as a result of poor workmanship. Make enough parts so that each cadet can assemble at least one aluminum model biplane. If some cadets finish ahead of others, they can make additional models or be assigned to making additional parts for additional models.

ACTIVITY

Time: 65 min

OBJECTIVE

Two objectives of this activity are for the cadets in each work group to set up their work area and also for the cadets to learn to mass produce the parts for aluminum model biplanes.

RESOURCES

- Instructions for constructing an aluminum model biplane,
- Example parts for each assembly line,
- Templates for constructing aluminum model biplane parts,
- Mechanic's gloves,
- Aluminum cans (36 per cadet),
- Softwood, 20 mm thick (fence boards),
- Bottle caps (ten per cadet),
- Corrugated cardboard,
- Tape (masking),
- Glue (two-part epoxy),
- Poster board (thin cardboard not corrugated),
- Mylar,
- Copper-coated welding rod or music wire (two sizes 1/16 inch and 3/32 inch),
- Ball-peen hammer,
- Pliers,
- Flat screwdriver,
- Rasp,
- Hand stapler,
- Staple gun,
- Push-pin,
- Hot glue gun,
- Awl,
- Wire cutter,
- Box knife,
- Scissors,
- Ruler,
- Felt-tipped pen,
- Needle-nose pliers,
- Adjustable wrench,
- Electric hand drill, and

- Hole saw bits (2-3/4 inch and 1-7/8 inch).

ACTIVITY LAYOUT

- Arrange assembly lines as shown in the layout figures located at Annexes U to AA.
- Provide a shop environment for the wood assembly line.

ACTIVITY INSTRUCTIONS

1. Organize the cadets into the work groups described at Annexes U to AA, providing them with wood jigs and prefabricated wood templates constructed from the templates in reference C3-146, or those located at Annex T, as required.
2. Assembly line assignments include:

Raw Aluminum Material Assembly Line (Annex U)

Prepare aluminum billets from aluminum cans by:

- a. washing the aluminum cans and removing the pull tabs;
- b. removing the bottom from one can per biplane (parts B-1 to stock);
- c. removing the bottom from one can per biplane leaving 2-inch tops (parts B-3 to stock); and
- d. removing the top and bottom from fifteen cans per biplane (raw blanks to stock).

Wood Assembly Line (Annex V)

Produce wood rounds for aluminum model biplane fuselages by:

- a. cutting 3/4 inch thick rounds (2-3/4 inch and 1-7/8 inch diameters); and
- b. tapering wood rounds 10 degrees to create F-1 and F-2.

Aluminum Billet Assembly Line (Annex W)

Cut cans vertically on the nutrition label (blanks).

Aluminum Panel Shearing Assembly Line (Annex X)

Using raw aluminum billets from stock, fabricate the following parts:

- a. aluminum panels (dimensions 2-5/8 inch by 8-1/8 inch) for under-wing panels, and
- b. aluminum panels (dimensions 3-5/8 inch by 8-1/8 inch) for wing panels bent 90 degrees on the 1/8 inch edge.

Cardboard Insert Assembly Line (Annex Y)

Fabricate the following parts from corrugated cardboard sheets:

- a. cardboard inserts for Bottom Wing (BWC) 7-1/4 inch by 2-5/8 inch,
- b. cardboard inserts for Bottom Wing (BWA) 6-1/2 inch by 3/4 inch,
- c. cardboard inserts for Top Wing (TWC) 18-1/4 inch by 2-3/4 inch,
- d. cardboard inserts for Top Wing (TWA) 18-1/4 inch by 3/4 inch,

- e. cardboard inserts for Horizontal Stabilizer (HS) from Template No. 8, and
- f. cardboard inserts for Vertical Stabilizers (VS) from Templates No. 9/10.

Wire Station Assembly Line (Annex Z)

Fabricate the following parts from wire stock:

- a. 3/32-inch welding rods 7-3/4 inches long and bend landing gear wire,
- b. 1/16-inch welding rods 6-3/4 inches and bend landing gear support wire,
- c. 3/32-inch wire 15-3/4 inches long for wing spars, and
- d. 3/32-inch wire 18 inches long for propeller shaft.

Drill Station Assembly Line (Annex AA)

Perform the following operations:

- a. Drill a 3/32-inch hole in the centre of bottle caps for wheels.
 - b. Drill a 3/32-inch hole in the centre of can B-1 for front fuselage.
 - c. Drill a 3/32-inch hole in the centre of can P-2 for propeller.
 - d. Drill a 3/32-inch hole in the centre of can P-1 for propeller face.
 - e. Enlarge holes A, B and C in fuselage assembly to 3/32 inch.
 - f. Enlarge hole D in fuselage assembly to 1/16 inch.
 - g. Enlarge holes E and F in fuselage assembly to 10-24 bolt size, as required.
 - h. Enlarge eight bolt holes in top wing for 10-24 bolts as required.
 - i. Enlarge four bolt holes for 10-24 bolts in bottom wing as required.
- 3. Inform the cadets that they will be rotated among the workstations.
 - 4. Assign the cadets to workstations.
 - 5. Have each work group produce units for prototype assembly as well as stock for assembly line start-up in subsequent mass production sessions.
 - 6. When sufficient parts have been fabricated for building more than two aluminum model biplanes, halt production and, as a demonstration in front of the class, assemble a prototype aluminum model biplane by combining the fuselage, upper wing and empennage. Do not attach propeller or landing gear at this stage.

SAFETY

- Supervised assembly lines, including the hole-saw station and the rasp station, will be used by one cadet at a time. Each of the supervised stations, using electric power tools, must be constantly supervised.
- Before beginning, ensure each cadet can perform the activity safely.
- Cadets shall wear mechanic's gloves while working with sharp materials.

CONFIRMATION OF TEACHING POINT 1

The cadets' participation in the activity will serve as the confirmation of this TP.

Teaching Point 2**Demonstrate, Explain and Have the Cadets Manufacture the Parts for Aluminum Model Biplanes**

Time: 120 min

Method: Practical Activity

ACTIVITY

OBJECTIVE

The objective of this activity is to have the cadets experience mass production of various aluminum model biplane parts at a variety of workstations.

RESOURCES

- Instructions for constructing an aluminum model biplane,
- Templates for constructing aluminum model biplane parts,
- Mechanic's gloves (one pair per cadet),
- Empty aluminum beverage cans (36 per cadet),
- Bottle caps (ten per cadet),
- Corrugated cardboard,
- Tape,
- Glue (two-part epoxy),
- Poster board (thin cardboard not corrugated),
- Mylar,
- Copper-coated welding rod or music wire (two sizes 1/16 inch and 3/32 inch),
- Ball-peen hammer,
- Pliers,
- Flat screwdriver,
- Hand stapler,
- Staple gun,
- Push-pin,
- Hot glue gun,
- Awl,
- Wire cutters,

- Box knife,
- Scissors,
- Ruler,
- Felt-tipped pen,
- Needle-nose pliers,
- Adjustable wrench,
- Electric hand drill, and
- Hole saw bits (2-3/4 inch and 1-7/8 inch).

ACTIVITY LAYOUT

A classroom with desks or tables for work groups with assignments.



Assembly lines can be combined to work together if space and manpower permit. Lines should be selected and set up based on resources such as cadet manpower, working area and also manufactured parts that are available from previous work sessions. For example, the Top Wing assembly line cannot begin without the aluminum panels and cardboard panels provided by previous assembly lines. However, the Top Wing Assembly Line (Annex AD) can operate concurrently with the Aluminum Panel Shearing Assembly Line (Annex X) and the Cardboard Insert Assembly Line (Annex Y) if space and manpower permit.

ACTIVITY INSTRUCTIONS

1. Assign cadets to workstations.
2. In addition to the work groups and assembly lines already used, if still required, the following work groups and assembly lines will be established as manpower becomes available:

Aluminum Rear Fuselage Assembly Line (Annex AB)

Fabricate the rear fuselage from the following parts:

- a. raw billets from scissor station,
- b. softwood parts F-1 from stock,
- c. softwood parts F-2 from stock, and
- d. fabricated rear fuselages from assembly stations 1–6.

Fuselage and Bottom Wing Assembly Line (Annex AC)

Combine parts B-1, B-2, wood rounds and staples to make fuselages and bottom wings.

Top Wing Assembly Line (Annex AD)

To fabricate top wings:

- a. combine cardboard parts TWC, TWAS and three pre-bent aluminum panels dimensions of 3-5/8 inch by 8-1/8 inch to form top wing (all from stock);

- b. insert panels (dimensions of 2-5/8 inch by 8-1/8 inch) under wing (from stock);
- c. staple top wing (ten staples); and
- d. apply Wing Bolt Hole Placement Template (WBHPT) to top of top wing and with a push-pin, make eight holes for bolts in the top wing (top wing to stock).

Empennage Assembly Line (Annex AE)

Fabricate the empennage by combining the following parts:

- a. aluminum horizontal stabilizer – Bottom,
- b. aluminum horizontal stabilizer – Top Right,
- c. aluminum horizontal stabilizer – Top Left,
- d. cardboard insert HS – Horizontal Stabilizer, and
- e. cardboard insert VS – Vertical Stabilizer.

Propeller Assembly Line (Annex AF)

Fabricate the fan propeller by combining the following parts:

- a. aluminum propeller, and
 - b. aluminum propeller cover.
3. Inform each work group of the number of parts they will make.
 4. As each work group completes fabrication of a particular part, have the cadets produce other parts until all parts required are in stock.
 5. Ensure that each cadet fabricates a variety of parts.

SAFETY

- Supervised assembly lines, including the hole-saw station and the rasp station, will be used by one cadet at a time. Each of the supervised stations, using electric power tools, must be constantly supervised.
- Before beginning, ensure each cadet can perform the activity safely.
- Cadets shall wear mechanic's gloves while working with sharp materials.

CONFIRMATION OF TEACHING POINT 2

The cadets' participation in the activity will serve as the confirmation of this TP.

Teaching Point 3

Demonstrate, Explain and Have the Cadet Construct an Aluminum Model Biplane

Time: 150 min

Method: Practical Activity

ACTIVITY

OBJECTIVE

The objective of this activity is to have the cadet assemble an aluminum model biplane.

RESOURCES

- One complete set of parts for one aluminum model biplane per cadet,
- Instructions for assembling an aluminum model biplane parts located at Annex AG,
- Tape (masking),
- Glue, and
- Tools, to include:
 - ball-peen hammer,
 - pliers,
 - flat screwdriver,
 - hand stapler,
 - staple gun,
 - glue gun,
 - awl,
 - wire cutters,
 - box knife,
 - scissors,
 - ruler,
 - felt-tipped pen,
 - needle-nose pliers, and
 - adjustable wrench.

ACTIVITY LAYOUT

N/A.

ACTIVITY INSTRUCTIONS

1. Divide the cadets into groups of four.

2. Demonstrate the assembly of the aluminum model biplane.
3. Ensure that every cadet is ready to proceed before moving to the next step in the assembly.
4. Assist each cadet with installation of landing gear to prevent tearing the aluminum fuselage.

SAFETY

Cadets shall wear mechanic's gloves while working with sharp material.

CONFIRMATION OF TEACHING POINT 3

The cadets' participation in the activity will serve as the confirmation of this TP.

END OF LESSON CONFIRMATION

The cadets' participation in aluminum model biplane parts fabrication and aluminum model biplane assembly will serve as the confirmation of this lesson.

CONCLUSION

HOMEWORK/READING/PRACTICE

N/A.

METHOD OF EVALUATION

N/A.

CLOSING STATEMENT

Construction of an aluminum model biplane using mass production of parts demonstrates one of the ways that society produces large volumes of equipment, including increasingly complex aircraft.

INSTRUCTOR NOTES/REMARKS

Templates, models and spare parts should be preserved for future training years.

Scheduling this lesson as a weekend activity will reduce preparation and cleanup.

Before beginning the instruction of this EO the instructor shall be familiar with the aluminum model biplane assembly techniques shown at references C3-146 and C3-160.

This lesson may be conducted over a number of separate sessions.

REFERENCES

- C3-146 Mathis, D. P. (2005). *Step by Step Construction Plans: Classic Biplane*. Helena, MT: BC Air Originals.
- C3-160 Mathis, D. P. (2007). *Building the B.C. Air Originals Biplane*. Helena, MT: B.C. Air Originals.

THIS PAGE INTENTIONALLY LEFT BLANK

PITOT STATIC SYSTEM AND TUBES

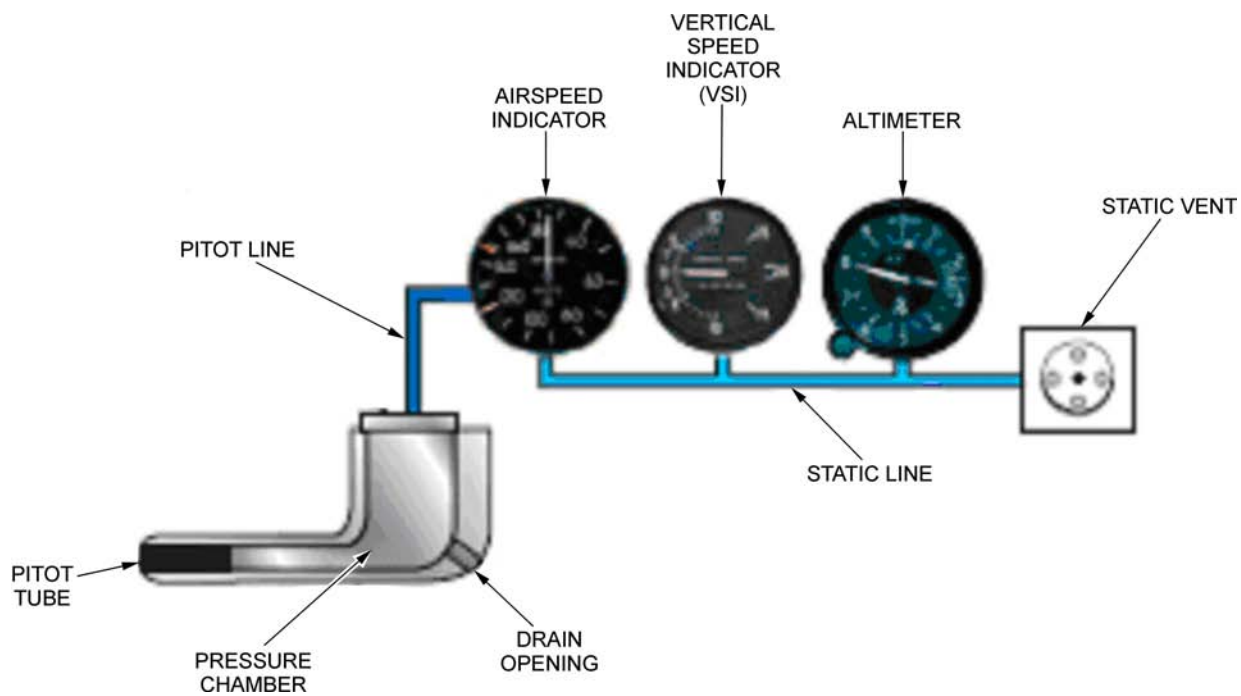

Pilot's Handbook of Aeronautical Knowledge, "Flight Instruments", 2003, United States Department of Transportation Federal Aviation Administration Flight Standards Service. Retrieved March 6, 2008, from http://www.faa.gov/library/manuals/aviation/pilot_handbook/

Figure 17A-1 The Pitot Static System

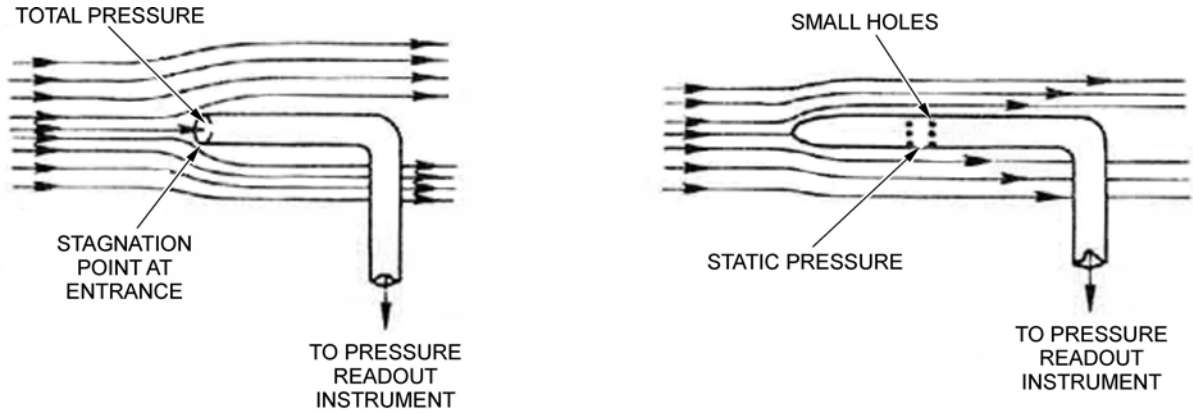

(A) PITOT TUBE

(B) STATIC TUBE

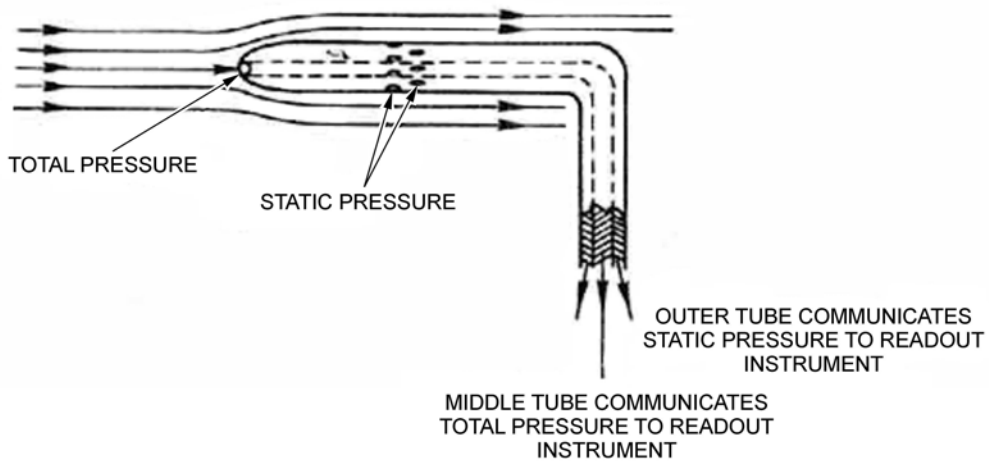

(C) PITOT-STATIC TUBE

NASA SP-367 Introduction to the Aerodynamics of Flight by T. A. Talay (1975), "Ideal Fluid Flow". Retrieved March 6, 2008, from <http://history.nasa.gov/SP-367/chapt3.htm#f27>

Figure 17A-2 Pitot Tubes, Static Tubes and Pitot Static Tubes

INDICATORS

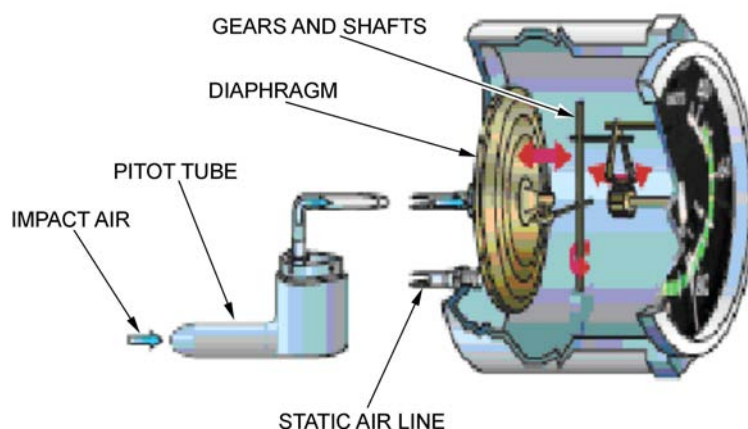

Pilot's Handbook of Aeronautical Knowledge, "Flight Instruments", 2003, United States Department of Transportation Federal Aviation Administration Flight Standards Service. Retrieved March 6, 2008, from http://www.faa.gov/library/manuals/aviation/pilot_handbook/

Figure 17B-1 Airspeed Indicator



North American Powered Parachute Federation, "Flight Instruments". Retrieved October 30, 2007, from http://www.nappf.com/nappf_flight_instruments.htm

Figure 17B-2 Airspeed Indicator Face

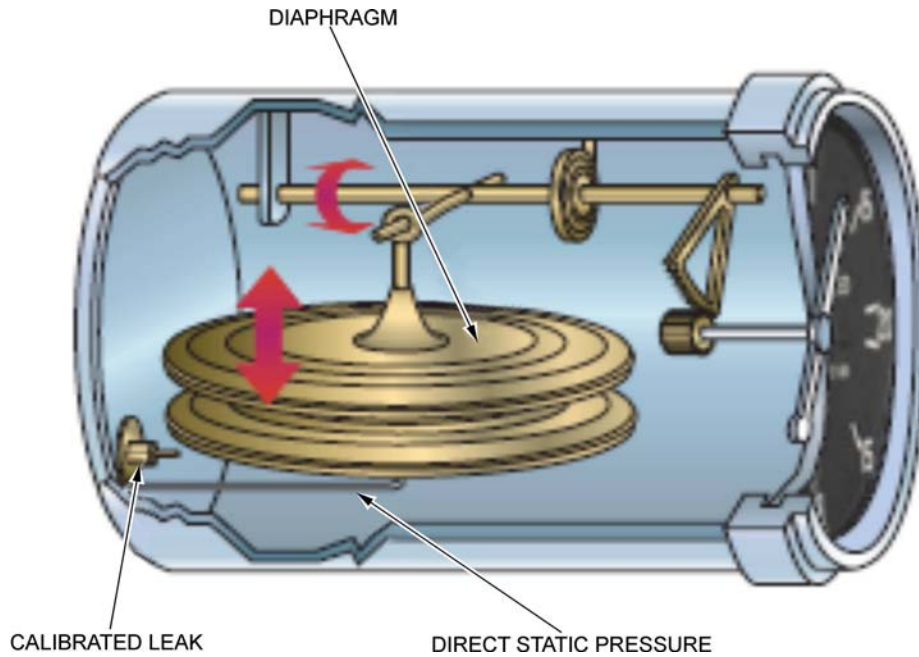

Pilot's Handbook of Aeronautical Knowledge, "Flight Instruments", 2003, United States Department of Transportation Federal Aviation Administration Flight Standards Service. Retrieved March 6, 2008, from http://www.faa.gov/library/manuals/aviation/pilot_handbook/

Figure 17B-3 Vertical Speed Indicator Parts



North American Powered Parachute Federation, "Flight Instruments". Retrieved October 30, 2007, from http://www.nappf.com/nappf_flight_instruments.htm

Figure 17B-4 Vertical Speed Indicator Face

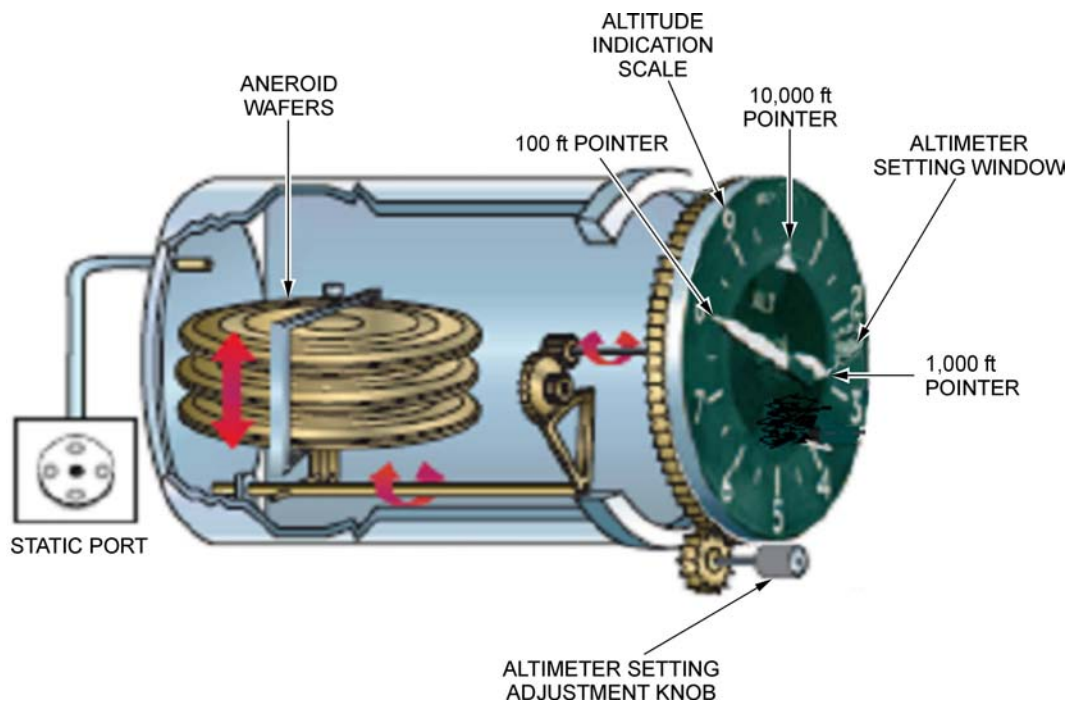

Pilot's Handbook of Aeronautical Knowledge, "Flight Instruments", 2003, United States Department of Transportation Federal Aviation Administration Flight Standards Service. Retrieved March 6, 2008, from http://www.faa.gov/library/manuals/aviation/pilot_handbook/

Figure 17B-5 Altimeter Parts



North American Powered Parachute Federation, "Flight Instruments". Retrieved October 30, 2007, from http://www.nappf.com/nappf_flight_instruments.htm

Figure 17B-6 Altimeter Face

THIS PAGE INTENTIONALLY LEFT BLANK

TYPES OF CESSNA AIRCRAFT

Cessna NGP	Cessna 310
Cessna CH-1 Helicopter	Cessna 320 Skynight
Cessna A	Cessna 335
Cessna BA	Cessna 336 Skymaster, O-2 Skymaster
Cessna AW	Cessna 337 Skymaster
Cessna AT-17 Bobcat	Cessna 340
Cessna C-34 Airmaster	Cessna 350 formerly the Columbia 350
Cessna T-37	Cessna 400 formerly the Columbia 400
Cessna 120	Cessna 401 Utiliner and Businessliner
Cessna 140	Cessna 402 Utiliner and Businessliner
Cessna 150 Commuter, Patroller & Aerobat	Cessna 404 Titan II
Cessna 152	Cessna 406 Caravan II
Cessna 160	Cessna 411
Cessna 162 Skycatcher	Cessna 414 Chancellor
Cessna 165 Airmaster	Cessna 421 Golden Eagle
Cessna 170	Cessna 425 Conquest I
Cessna 172 Skyhawk, T-41 Mescalero	Cessna 441 Conquest II
Cessna 175 Skylark	Cessna 500 Citation I
Cessna 177 Cardinal	Cessna 501 Citation ISP
Cessna 180 Skywagon	Cessna 510 Citation Mustang
Cessna 182 Skylane	Cessna 525 Citation Jet, CJ1, CJ1+
Cessna 185 Skywagon	Cessna 525A CJ2, CJ2+
Cessna 187	Cessna 525B CJ3
Cessna 188 AGwagon, AGpickup, AGtruck, and AGhusky	Cessna 550 Citation II, Cessna Citation Bravo
Cessna 190	Cessna 551 Citation IISP
Cessna 195	Cessna S550 Citation SII
Cessna 205 Super Skywagon	Cessna 560 Citation V, Citation Ultra, Citation Encore, Citation Encore+
Cessna 206 Stationair & Super Skylane	Cessna Citation 560XL Excel, XLS, XLS+
Cessna 207 Skywagon, Stationair 7 & 8	Cessna 620
Cessna 208 Caravan	Cessna 650 Citation III, Citation VI, Citation VII
Cessna 210 Centurion	Cessna 680 Citation Sovereign
Cessna 303	Cessna 750 Citation X
Cessna 305 Bird Dog	Cessna 850 Citation Columbus



Wikimedia Commons by Adrian Pingstone, 2005, "Cessna 172G". Retrieved March 10, 2008, from <http://en.wikipedia.org/wiki/Image:Cessna.f172g.g-bgmp.arp.jpg>

Figure 17C-1 Cessna 172 Skyhawk



*Cessna.com: Our Aircraft, 2008, "Amphibian Cessna Caravan".
Retrieved March 16, 2008, from <http://caravanamphib.cessna.com/#>*

Figure 17C-2 Cessna 208 Caravan Amphibian



*Wikimedia Commons by Adrian Pingstone, 2005, "Cessna 404".
Retrieved March 10, 2008, from http://en.wikipedia.org/wiki/Cessna_404*

Figure 17C-3 Cessna 404 Titan II



Cessna emedia, 2008, "Citation image gallery". Retrieved March 16, 2008, from <http://cessna.com/news/gallery/index.php?model=mustang>

Figure 17C-4 Cessna 510 Citation Mustang



RCA OPS (PAC), 2005, "Aircraft operating instructions Cessna 305 aircraft". Retrieved March 16, 2008, from <http://www.regions.cadets.forces.gc.ca/pac/rgs/doc/L19%20AOIs%201%20Jun%2006%20-%20Complete%20version.pdf>

Figure 17C-5 Cessna 305 (L-19 Bird Dog)

DIAMOND



Diamond Aircraft: The Ultimate Fleet, 2008, "DA20 Eclipse". Retrieved March 16, 2008, from <http://www.diamondair.com/aircraft.php>

Figure 17D-1 Diamond DA20 Eclipse



Diamond Aircraft: The Ultimate Fleet, 2008, "DA42 Twin". Retrieved March 16, 2008, from <http://www.diamondair.com/aircraft.php>

Figure 17D-2 Diamond DA42 Twin Star



Diamond Aircraft D-Jet, 2006, "D-Jet: The features". Retrieved March 16, 2008 from http://www.diamond-air.at/fileadmin/uploads/files/productfacts/d-jet/D_JETbrochure.pdf

Figure 17D-3 Diamond D-Jet

THIS PAGE INTENTIONALLY LEFT BLANK

PIPER



*Piper Aircraft Inc., 2008, "Piper freedom of flight: Heritage" at website
Retrieved March 16, 2008, from <http://www.piper.com/company/heritage.asp>*

Figure 17E-1 Forerunner of the Piper Cub



Controller, "1979 Piper Aztec F", Copyright 2008 by Sandhills Publishing Company. Retrieved March 16, 2008, from <http://www.controller.com/listings/aircraft-for-sale/PIPER-AZTEC-F/1979-PIPER-AZTEC-F/1126249.htm?guid=450D7ACC60104829A0081C4C7E88EFED>

Figure 17E-2 Piper Aztek on Final



Piper Freedom of Flight "Piper unveils the revolutionary piperjet" Retrieved March 12, 2008, from <http://www.prnewswire.com/mnr/carlisle/25816/>

Figure 17E-3 Piper Jet

THIS PAGE INTENTIONALLY LEFT BLANK

VIKING AIR (DE HAVILLAND ORIGINAL PRODUCTS)



"Canada's Air Force", Image Gallery photo search (2007). Retrieved March 8, 2008, from http://www.airforce.forces.gc.ca/site/imagery/search_e.asp

Figure 17F-1 de Havilland DHC-6 Twin Otter (CC-138 Twin Otter)



*Viking Air A New Beginning for a Canadian Legend, 2008, DHC-2T Turbo Beaver.
Retrieved March 16, 2008, from <http://www.vikingair.com/content.aspx?id=270#>*

Figure 17F-2 de Havilland DHC-2T Turbo Beaver



"Canada's Air Force", Image Gallery photo search (2007). Retrieved March 8, 2008, from http://www.airforce.forces.gc.ca/site/imagery/search_e.asp

Figure 17F-3 de Havilland DHC 5 Buffalo (CC-115 Buffalo)

THIS PAGE INTENTIONALLY LEFT BLANK

AIRBUS



Wikimedia Commons by Adrian Pingstone, 2005, "Airbus A300B4-603". Retrieved March 10, 2008, from <http://en.wikipedia.org/wiki/Image:Luft.a300b4.d-aias.750pix..jpg>

Figure 17G-1 Airbus A300



Wikimedia Commons by Adrian Pingstone, 2005, "Airbus A310-200". Retrieved March 10, 2008, from <http://en.wikipedia.org/wiki/Image:Fedex.a310-200.n420fe.arp.jpg>

Figure 17G-2 Airbus A310



Air Canada: Our Fleet, 2007, "Airbus A320-200 (320)". Retrieved March 16, 2008, from <http://www.aircanada.com/en/about/fleet/a320-200xm.html>

Figure 17G-3 Airbus A320



Air Canada: Our Fleet, 2007, "Airbus A330-300 (333)". Retrieved March 16, 2008, from <http://www.aircanada.com/en/about/fleet/a330-300.html>

Figure 17G-4 Airbus A330



Air Canada: Our Fleet, 2007, "Airbus A340-300 (343)". Retrieved March 16, 2008, from <http://www.aircanada.com/en/about/fleet/a340-300.html>

Figure 17G-5 Airbus A340



Airbus Multimedia Library Images, 2007, "The A380". Retrieved March 16, 2008, from http://www.airbus.com/store/photolibrary/AIRCRAFT/AIRBUS/A380/att00009804/media_object_image_lowres_A380_touchdown

Figure 17G-6 Airbus A380

THE BOEING COMPANY



Boeing Commercial Airplanes: Out of Production, "707". Copyright 2008. Retrieved March 16, 2008, from <http://www.boeing.com/commercial/gallery/707-04.html>

Figure 17H-1 Dash-80 First Boeing 707



Air Canada: Historical Fleet, 2007, "737-200". Retrieved March 16, 2008, from <http://www.aircanada.com/shared/images/common/fleet/pictures/737b.jpg>

Figure 17H-2 Boeing 737



Air Canada: Historical Fleet, 2007, "747-400". Retrieved March 16, 2008, from <http://www.aircanada.com/shared/images/common/fleet/pictures/747combi.jpg>

Figure 17H-3 Boeing 747



*Air Canada: Our Fleet, 2007, "767-300". Retrieved March 16, 2008,
from <http://www.aircanada.com/en/about/fleet/b767-300er.html>*

Figure 17H-4 Boeing 767



Air Canada: Our Fleet, 2007, "777-300ER". Retrieved March 16, 2008, from <http://www.aircanada.com/en/about/fleet/77W.html>

Figure 17H-5 Boeing 777

THIS PAGE INTENTIONALLY LEFT BLANK

AIR CANADA'S FLEET

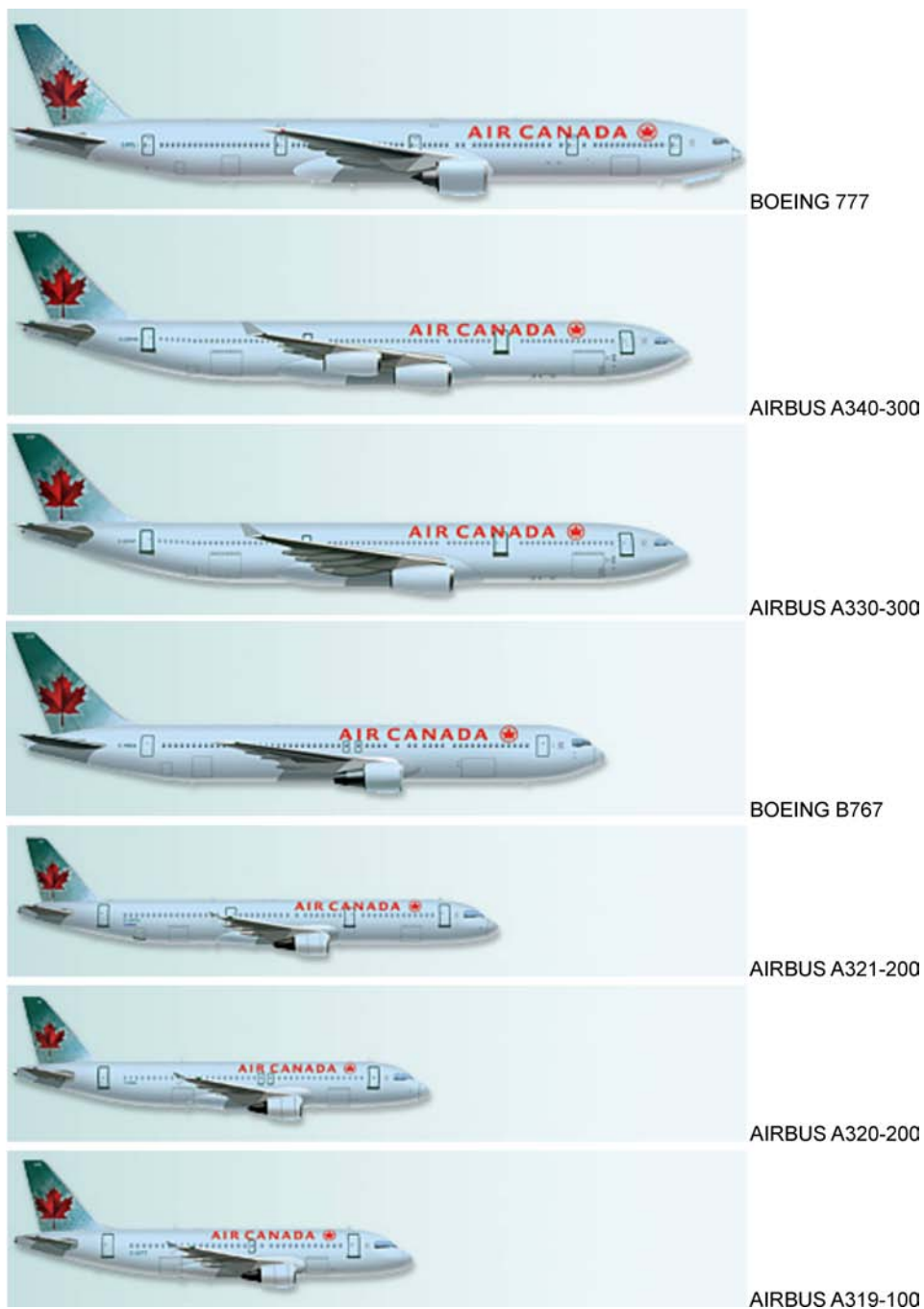

Air Canada, 2008, "Our Fleet". Retrieved March 16, 2008, from <http://www.aircanada.com/en/about/fleet/>

Figure 171-1 Air Canada Fleet Comparison

THIS PAGE INTENTIONALLY LEFT BLANK

SKYHAWK CHECKLIST

Cessna 172	Preflight	Cessna 172	In Flight
Preflight Inspection Cockpit			Cruise
Aircraft docs (ARROW) Check	Alternator belt Check	Transponder Standby	Pitch Set
Weight & Balance Check	Air intake Check	Flaps Up	Throttle As required
Parking Brake Set	Carburetor air filter Check	Ammeter Check	Trim Set
Control wheel lock Remove	Landing lights Check	Heading Indicator Set	Mixture Adjust
Hobbs/Tach Check/Remove	Nose wheel strut & tire Check	ATIS/AWOS/ASOS Obtain	
Ignition Off	Nose-Tie down Disconnect	Altimeter Set	Pre-landing checklist
Avionics Power Switch Off	Static source opening Check	Autopilot Engage	Fuel selector On
Master Switch On	Left Wing	Flight Controls Move Against AP	Mixture Rich
Fuel quantity indicators Check	Wing tie-down Disconnect	Autopilot Disconnect (Sound)	Carb Heat On
Pitot Heat On	Aileron Free and Secure	Departure & Taxi Clmce Contact	Seatbelts Fastened
Avionics Master Switch On	Flaps Secure	Before Takeoff	Approach
Avionics Cooling Fan Audible	Main wheel tire Inflated/Cond	Parking brake Set	Flight instruments Ckd & Set
Avionics Master Switch Off	Brakes Not Leaking	Cabin doors Closed & Locked	Radios Checked
Static Pressure Alt Src Valve Off	Fuel tank vent open Check	Seats, belts Adjust & Lock	ATIS Checked
Annunciator Panel Switch Test	Fuel tank sump Sample	Flight controls Free & Correct	Carb Heat On (Out)
Annunciator's Illuminate Check	Fuel Quantity Check	Instruments (4) Set	Mixture Rich
Annunciator Panel Switch Off	Fuel Filler cap Secure	Fuel Quantity Check	Landing light On
Flaps Extend	Pitot tube Uncover and Check	Fuel Shutoff Valve On	Airspeed 65-75 KIAS (Flaps Up)
Pitot Heat Off	Stall warning Check	Mixture Rich (IN)	60-70 KIAS (Flaps Dn)
Master Switch Off	Landing/Taxi Light(s) Clean/Cond	Fuel Selector Valve Both	After landing
Pitot Tube Test for Heat	Before starting engine	Elevator Trim Set for TAKEOFF	Flaps Up
Fuel shutoff valve On (In)	Preflight inspection Complete	Throttle 1800 rpm	Carb Heat Cold (In)
Fuselage and Empenage	Passenger Briefing Complete	Magnetos Check	Transponder Standby
Baggage Door Closed & Locked	Seats, belts Adjust & Lock	Suction gage Check	Landing light Off
Rivets Check	Doors Closed & Locked	Engine Instruments Check	Parking
Rudder Gust Lock Remove	Brakes Test & Set	Ammeter Check	Avionics Off
Tail Tie-Down Disconnect	Circuit breakers Check In	Mixture Set for Density Alt	Electrical Off
Control surfaces Free & Secure	Electrical Equip/Autopilot Off	Carb heat On	Throttle 1000 RPM
Trim Tab Check Security	Avionics Power Switch Off	Annunciator Panel Clear	Mixture Cut-off
Antennas Check Security	Fuel Selector Valve Both	Throttle 1000 rpm	Ignition switch Off
Right wing	Fuel shutoff valve On (In)	Throttle Friction Lock Adjust	Master switch Off
Wing tie-down Disconnect	Starting Engine	Strobe Lights On	Securing the aircraft
Aileron Free and Secure	Throttle Open 1/4 inch	Radios/Avionics Set	Control Lock Install
Flaps Secure	Mixture Rich (IN)	Autopilot Off	Hobbs/Tach Record
Main wheel tire Inflated/Cond	Carb heat Cold (IN)	Flaps Set for Takeoff (0°-10°)	Door/Window Secure
Brakes Not Leaking	Prime As required; locked	Parking Brake Release	Tie-downs Secure
Fuel tank sump Sample	Aux Fuel Pump On	Windows Closed	Comm Freq
Fuel Quantity Check	Propeller area Clear	Takeoff	
Fuel Filler cap Secure	Master Switch On	Flaps Up	ATIS
Nose	Beacon On	Carb heat Cold (In)	Ground
Engine oil level Check	Ignition Start	Transponder Altitude	Tower
Fuel strainer Sample	Throttle Adjust 1000 rpm	Trim set for TAKEOFF	Club
Propeller and spinner Check	Oil Pressure Check normal	Throttle Full	Fuel
	Aux Fuel Pump Off	Tach, oil, airspeed Check	
	Avionics Master Switch On	Elevator Lift at 55 KIAS	
	Radios On	Climb 70-80 KIAS	

International Flying Club, 2005, "Cessna 172 Preflight Cessna 172 In Flight". Retrieved March 17, 2008, from <http://www.internationalflyingclub.org/docs/c172-chklist.pdf>

Figure 17J-1 Skyhawk Checklist

THIS PAGE INTENTIONALLY LEFT BLANK

**ELEMENTARY WORK TASK LISTINGS FROM STANDARD 625 APPENDIX A – ELEMENTARY WORK,
CANADIAN AVIATION REGULATIONS PART VI – GENERAL OPERATING AND FLIGHT RULES**

1. fabric patches measuring not more than 15 cm (6 in) in any direction and not requiring rib stitching or the removal of control surfaces or structural parts, on small privately operated aircraft;
2. removal and replacement of tires, wheels, landing skids or skid shoes, not requiring separation of any hydraulic lines, on small privately operated aircraft;
3. removal and replacement of skis on fixed landing gear, not requiring separation of any hydraulic lines, on small privately operated aircraft;
4. repair of non-structural fairings, cover plates and cowlings, on small privately operated aircraft;
5. cleaning and replacement of spark plugs, on small privately operated aircraft;
6. checking of cylinder compression, on small privately operated aircraft;
7. cleaning or changing of fuel, oil, and air filters, on small privately operated aircraft;
8. draining and replenishing engine oil, on small privately operated aircraft;
9. checking the electrolyte level and specific gravity of lead acid batteries, on small privately operated aircraft;
10. adjustment of generator or alternator drive belt tension, on small privately operated aircraft;
11. cleaning of balloon burner nozzles;
12. removal and replacement of balloon baskets, burners and gas tanks that are designed for rapid change in service;
13. removal and replacement of glider wings and tail surfaces that are designed for quick assembly;
14. repair of upholstery, trim and cabin furnishings;
15. removal and replacement of role equipment designed for rapid removal and replacement;
16. removal and replacement of passenger seat belts and harnesses;
17. removal and replacement of fuses, light bulbs and reflectors;
18. removal and replacement of avionics components that are rack mounted or otherwise designed for rapid removal and replacement, where the work does not require testing other than an operational check;
19. removal and replacement of aircraft batteries;
20. removal and replacement of co-pilot control levers, wheels, pedals and pedal guard plates that are designed for rapid removal and replacement, on other than transport category aircraft;
21. opening and closing of non-structural access panels;
22. removal and replacement of cabin doors on unpressurized aircraft, where the door is designed for rapid removal and replacement;
23. removal, replacement and repositioning of non structural partitions in the passenger cabin;
24. inspection and continuity checking of self-sealing chip detectors;
25. removal and replacement of induction system anti-icing baffles, scoops and deflectors that are designed for rapid removal and replacement;

26. removal, cleaning, replacement and adjustment of external components of chemical dispersal systems that are designed for rapid removal and replacement;
27. deactivating or securing inoperative systems in accordance with sections 605.09 or 605.10 of the CARs, including the installation of devices specifically intended for system deactivation, where the work does not involve disassembly, the installation of parts, or testing other than operational checks;
28. checking and adjusting air pressure in helicopter floats, and aircraft tires having an operating pressure below 100 psi, except on aircraft operated under CAR 704 and CAR 705; and
29. repetitive visual inspections or operational checks (including inspections and tests required by airworthiness directives) not involving disassembly or the use of visual aids, performed out of phase with the aircraft's scheduled check cycle at intervals of less than 100 hours air time, provided the tasks are also included in the most frequent scheduled maintenance check.

THIS PAGE INTENTIONALLY LEFT BLANK

WOODEN AIRCRAFT



"The Aviation History Online Museum", 2007, Aircraft: Sopwith Triplane. Retrieved November 25, 2007, from <http://www.aviation-history.com/sopwith/triplane.htm>

Figure 17N-1 The Black Maria Sopwith Triplane

THIS PAGE INTENTIONALLY LEFT BLANK

COMPOSITE MATERIALS USED IN AIRCRAFT CONSTRUCTION



"A380 Navigator", 2007, Manufacturing Process. Retrieved November 24, 2007, from <http://events.airbus.com/A380/Default2.aspx?ArtId=644>

Figure 17O-1 A380 Rear Pressure Bulkhead

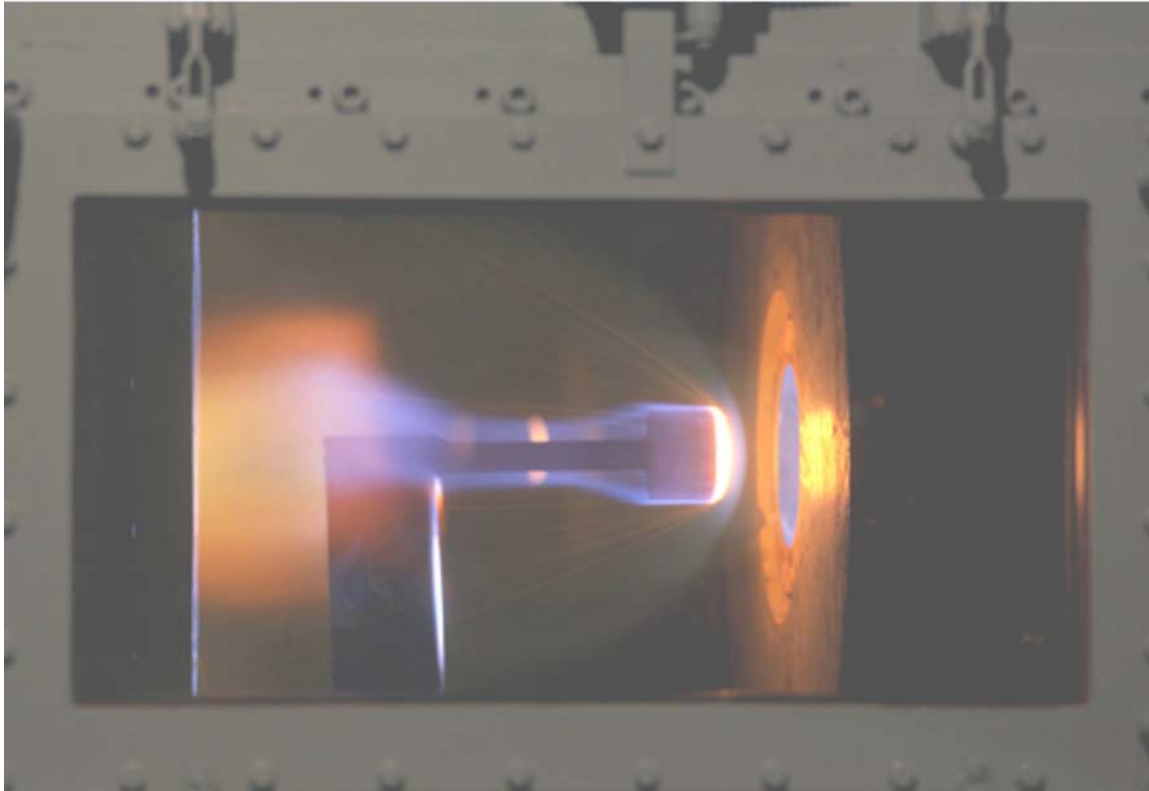

"US Centennial of Flight Commission", 2004, Shuttle Thermal Protection System. Retrieved November 25, 2007, from http://www.centennialofflight.gov/essay/Evolution_of_Technology/TPS/Tech41.htm

Figure 17O-2 Testing Thermal Insulation in a Wind Tunnel

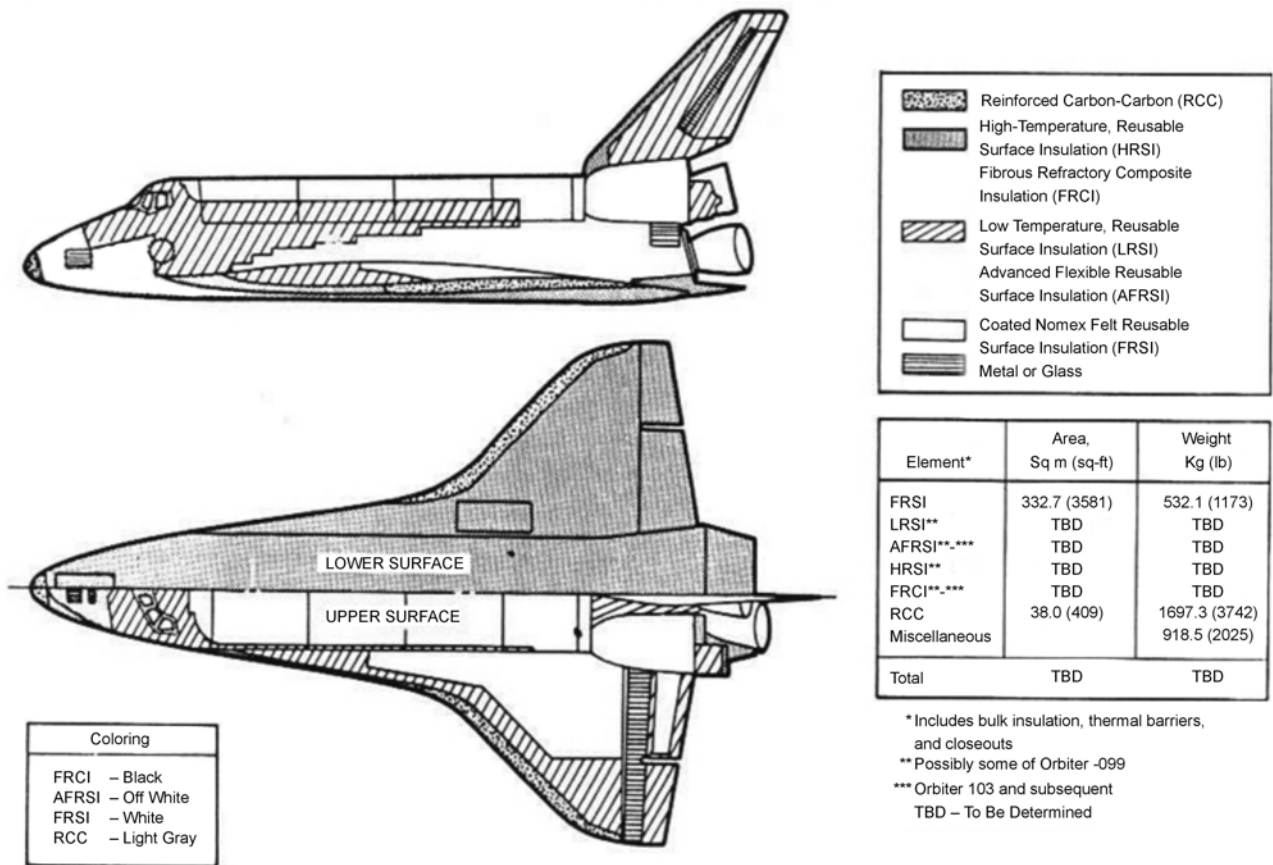

“US Centennial of Flight Commission”, 2004, Shuttle Thermal Protection System. Retrieved November 25, 2007, from http://www.centennialofflight.gov/essay/Evolution_of_Technology/TPS/Tech41.htm

Figure 17O-3 Orbiter Thermal Protection System



"US Centennial of Flight Commission", 2004, Shuttle Thermal Protection System. Retrieved November 25, 2007, from http://www.centennialofflight.gov/essay/Evolution_of_Technology/TPS/Tech41.htm

Figure 17O-4 Repairing TPS on Columbia

METAL USED IN AIRCRAFT CONSTRUCTION



"A380 Navigator", 2007, Manufacturing Process. Retrieved November 24, 2007, from <http://events.airbus.com/A380/Default2.aspx?ArtId=644>

Figure 17P-1 Titanium Pylon for an A380 Airbus Engine



"A380 Navigator", 2007, Manufacturing Process. Retrieved November 24, 2007, from <http://events.airbus.com/A3>

Figure 17P-2 Empty Pylons on an A380 Airbus

THIS PAGE INTENTIONALLY LEFT BLANK

POWER TOOLS

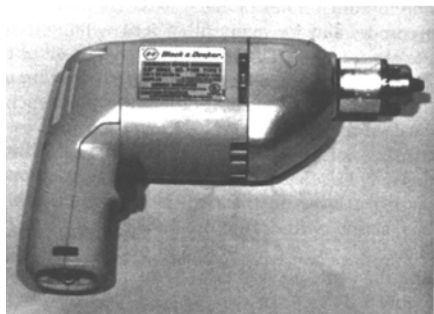

ELECTRIC



PNEUMATIC

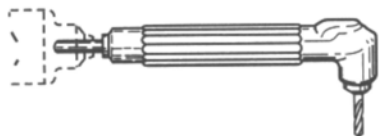

RIGHT ANGLE



FLEXIBLE DRIVE RIGHT ANGLE



FLEXIBLE DRIVE STRAIGHT

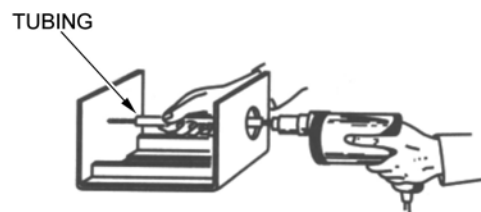

LONG DRILL BIT APPLICATION

A&P Technician Airframe Textbook, Sanderson Training Systems (pp. 2-24 to 2-26)

Figure 17Q-1 Various Drill Types

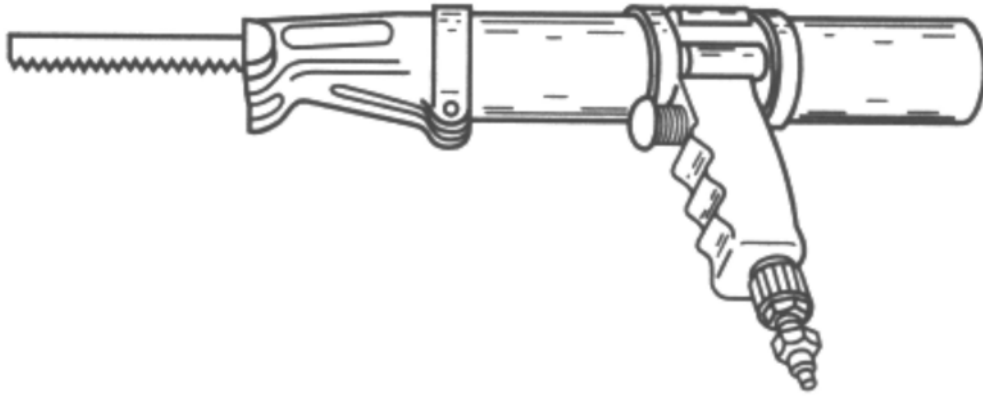

A&P Technician Airframe Textbook, Sanderson Training Systems (pp. 2-19)

Figure 17Q-2 Reciprocating Saw

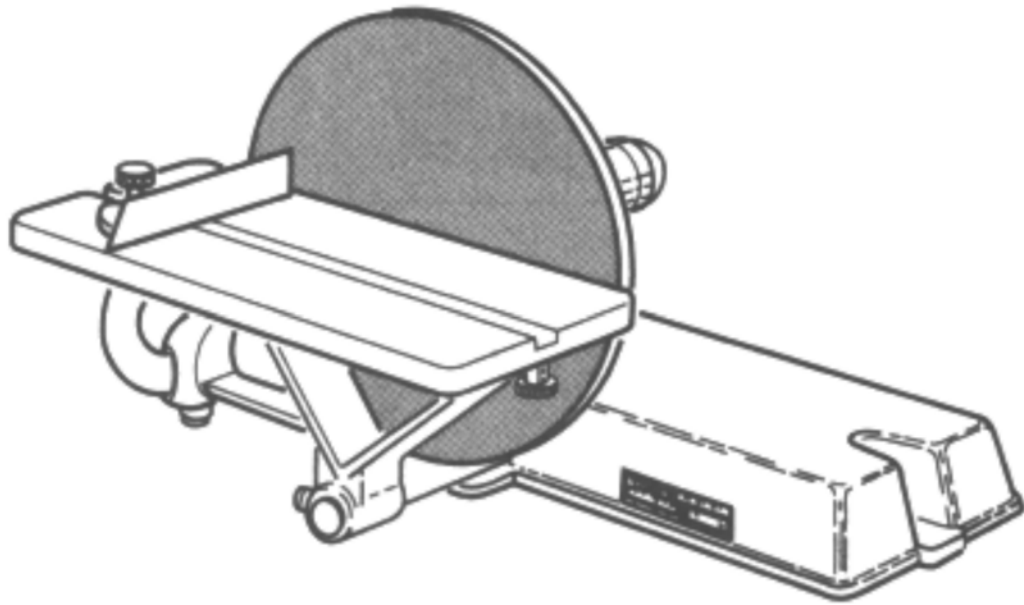

A&P Technician Airframe Textbook, Sanderson Training Systems (pp. 2-24)

Figure 17Q-3 Disk Sander

THIS PAGE INTENTIONALLY LEFT BLANK

FORMING AND CUTTING TOOLS

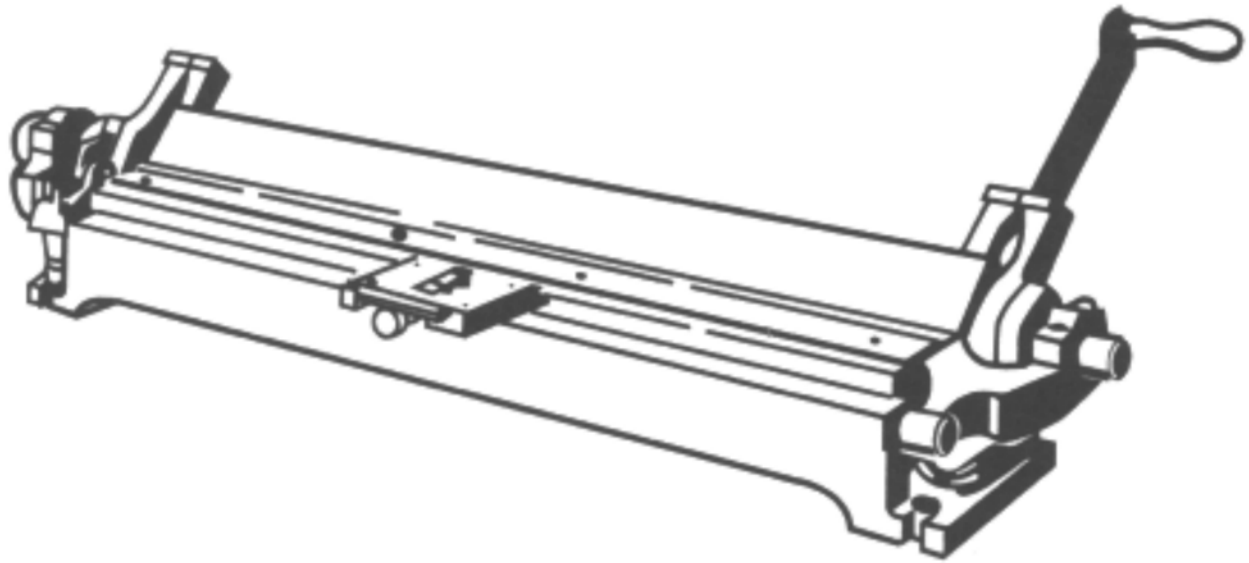

A&P Technician Airframe Textbook, Sanderson Training Systems (pp. 2-30)

Figure 17R-1 Bar Folding Machine

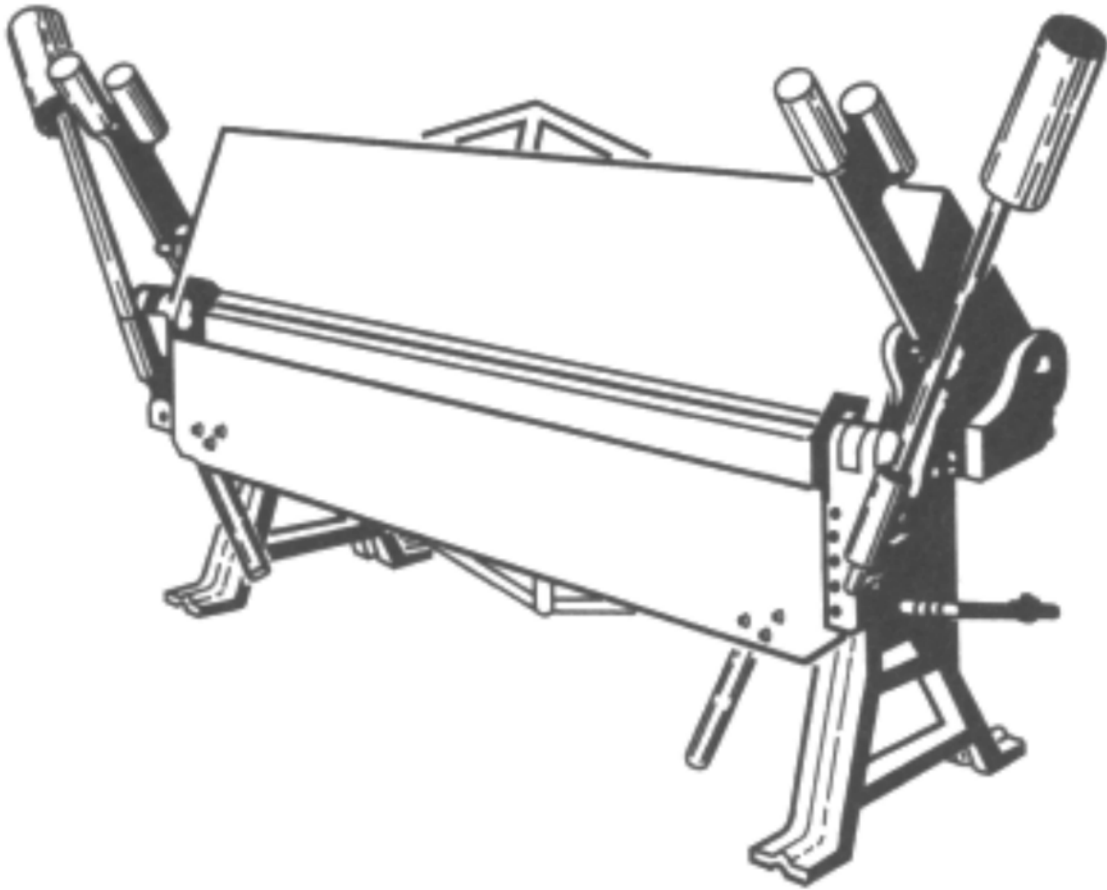

A&P Technician Airframe Textbook, Sanderson Training Systems (pp. 2-29)

Figure 17R-2 Cornice Break

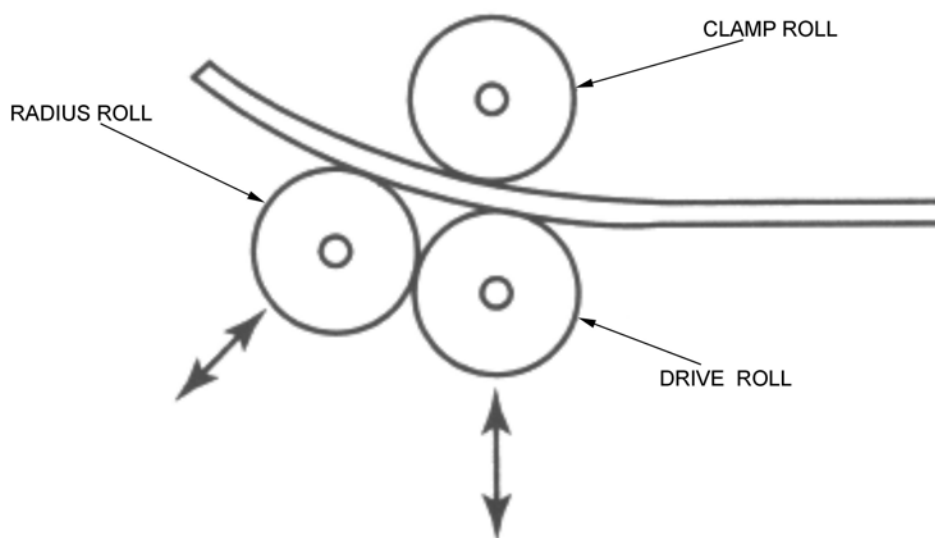
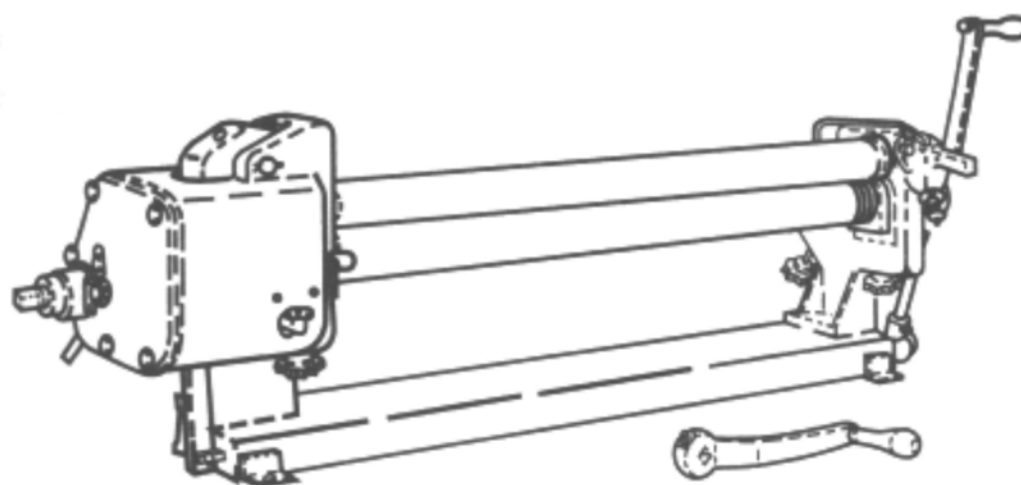

A&P Technician Airframe Textbook, Sanderson Training Systems (pp. 2-31)

Figure 17R-3 Slip Roll Former



Triway YangZhong International Trade Company, Hydropress. Retrieved November 17, 2007, from <http://www.nantex-triway.com/equipment.htm>

Figure 17R-4 Hydropress

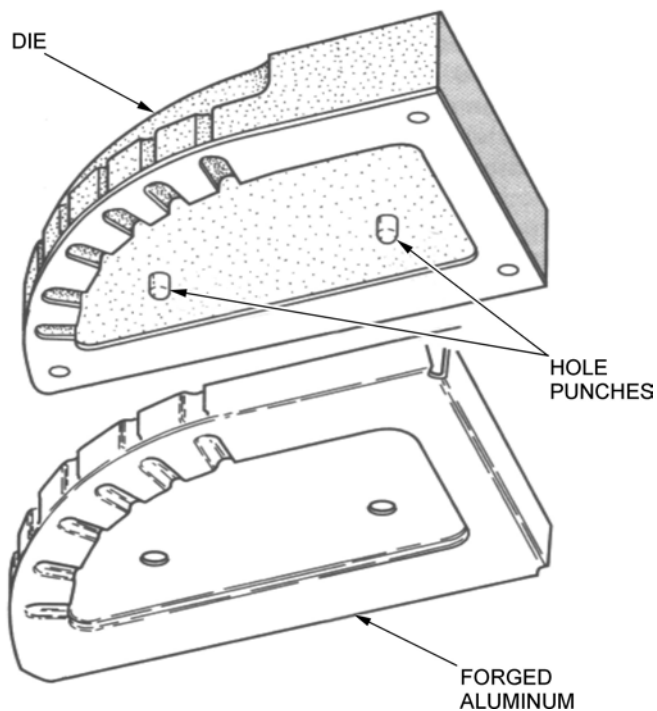

A&P Technician Airframe Textbook, Sanderson Training Systems (pp. 2-32)

Figure 17R-5 Hydropress Die With Forged Aluminum Product

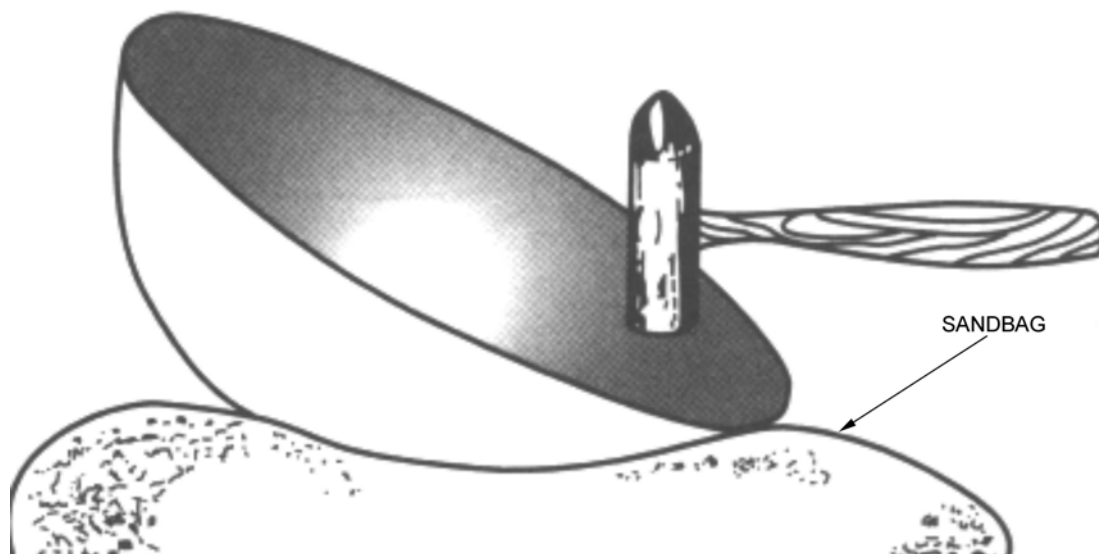

A&P Technician Airframe Textbook, Sanderson Training Systems (pp. 2-32)

Figure 17R-6 Sandbag Forming

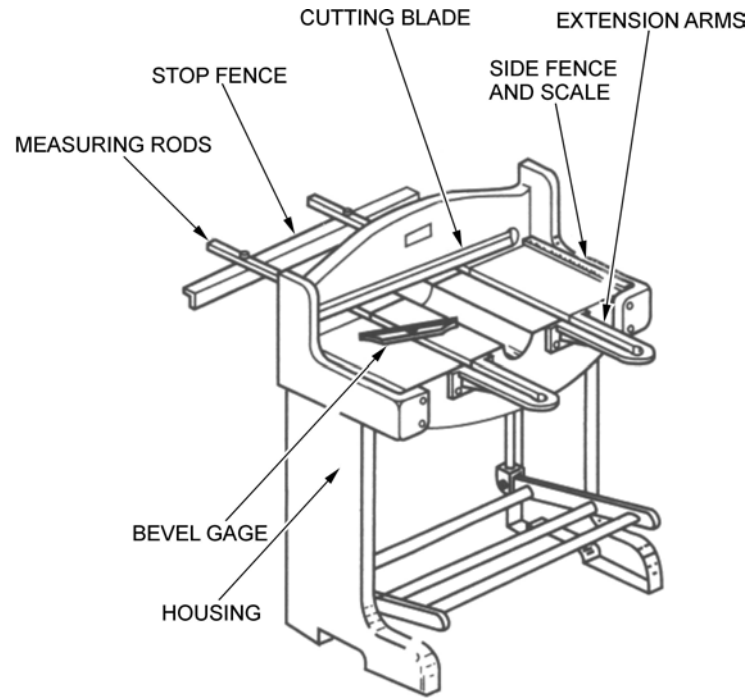

A&P Technician Airframe Textbook, Sanderson Training Systems (pp. 2-22)

Figure 17R-7 Squaring Shear

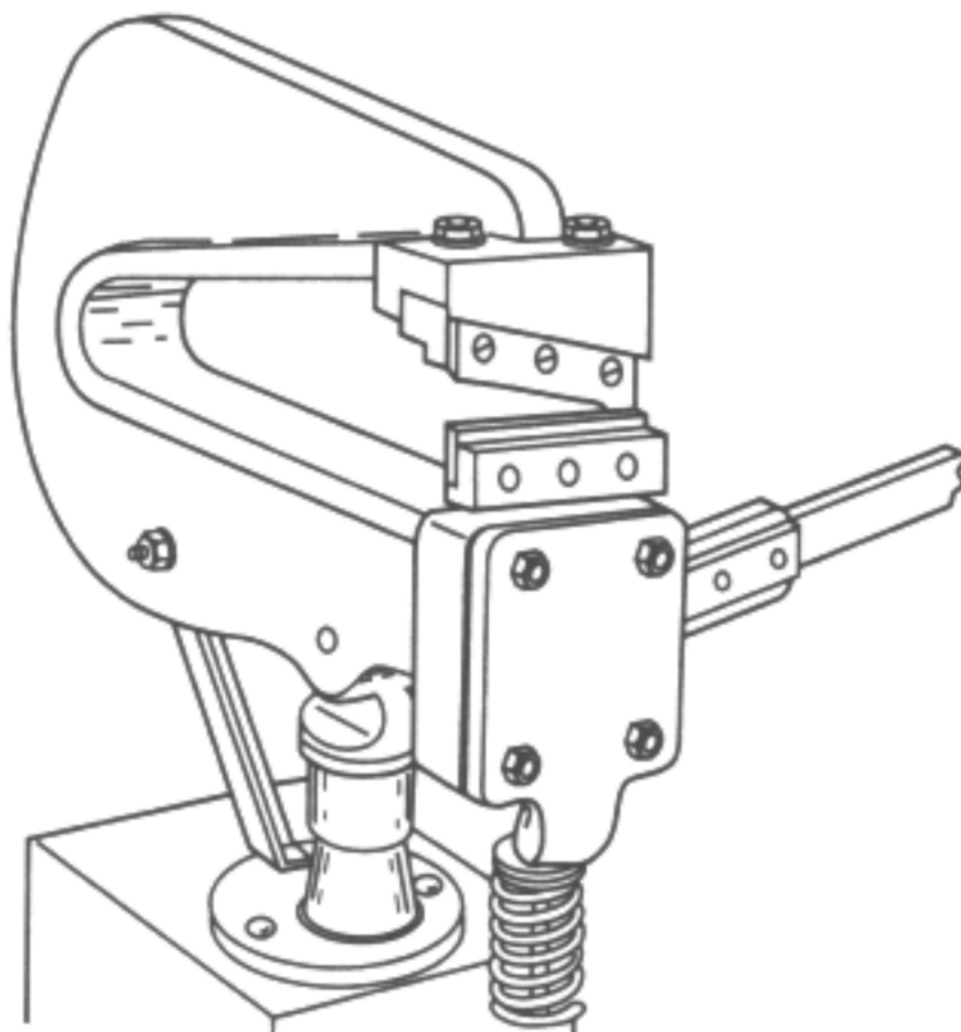

A&P Technician Airframe Textbook, Sanderson Training Systems (pp. 2-24)

Figure 17R-8 Scroll Shears

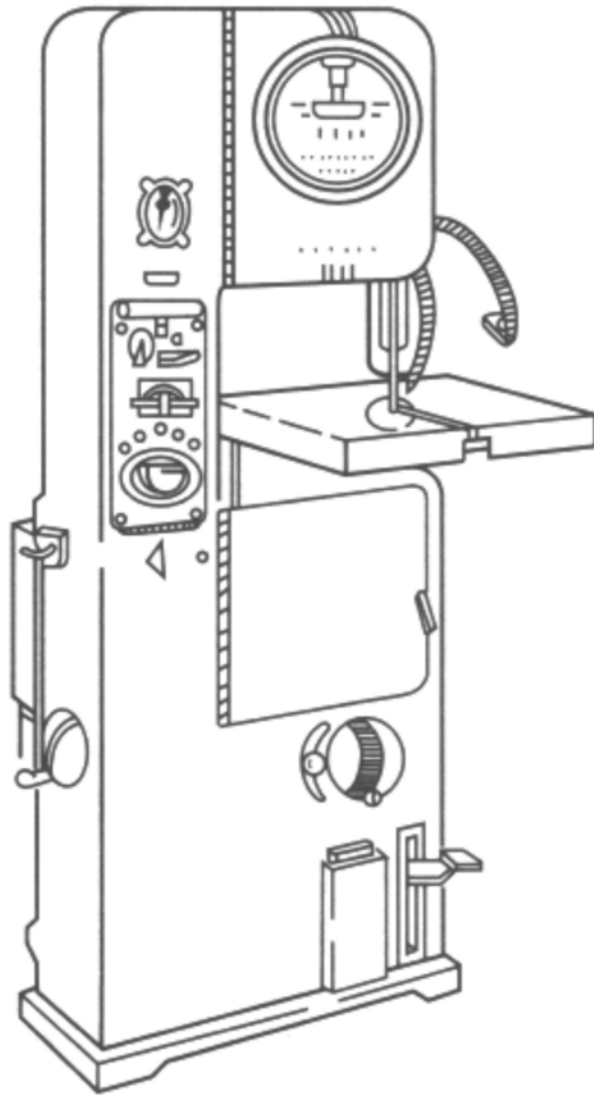

A&P Technician Airframe Textbook, Sanderson Training Systems (pp. 2-23)

Figure 17R-9 Band Saw

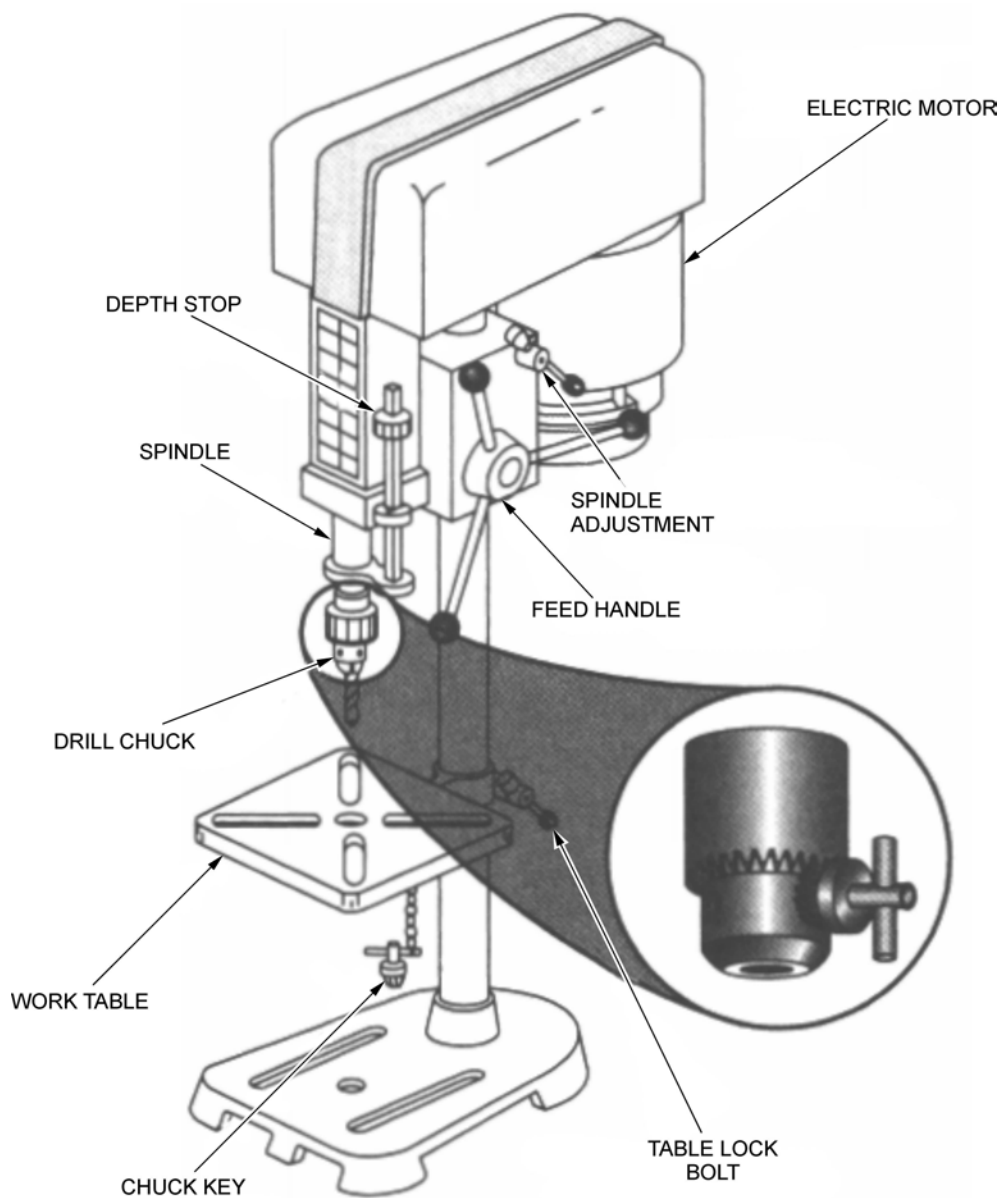

A&P Technician Airframe Textbook, Sanderson Training Systems (pp. 2-26)

Figure 17R-10 Drill Press

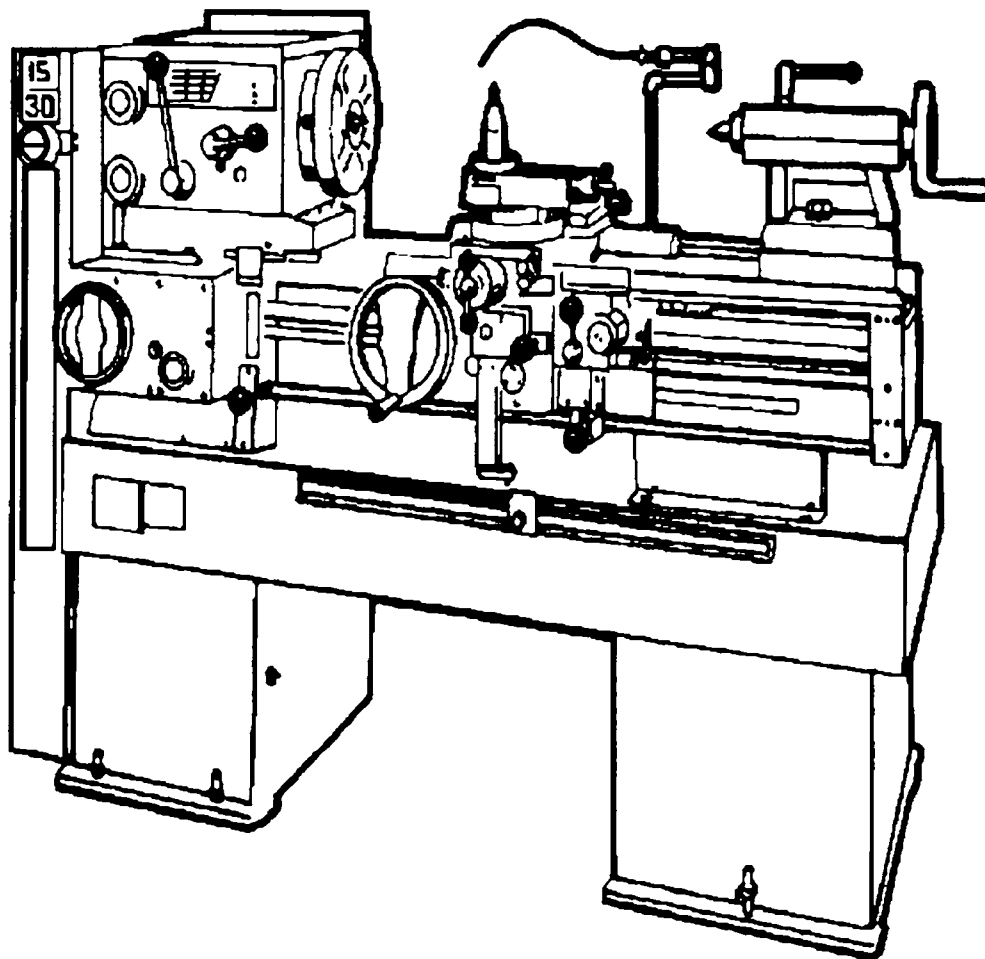

Fundamentals of Machine Tools, Headquarters Department of the Army Washington DC ,1996, Training Circular No. 9-524. Retrieved November 23, 2007, from <http://metalworking.com/tutorials/army-TC-9-524/TOC.pdf>

Figure 17R-11 Metal Lathe

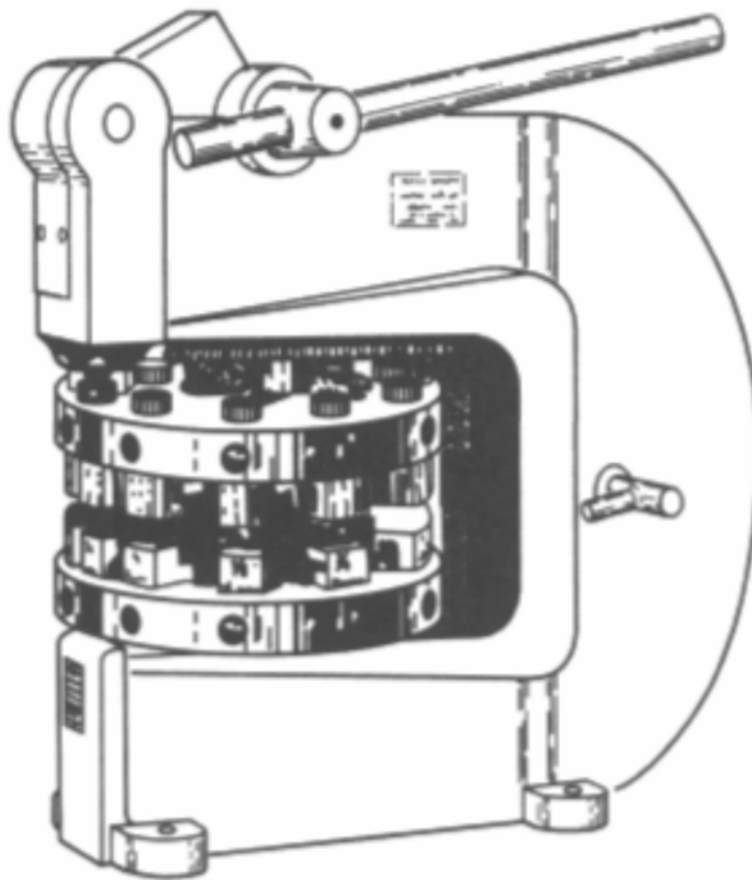

A&P Technician Airframe Textbook, Sanderson Training Systems (pp. 2-23)

Figure 17R-12 Rotary Punch

THIS PAGE INTENTIONALLY LEFT BLANK

FASTENING TOOLS

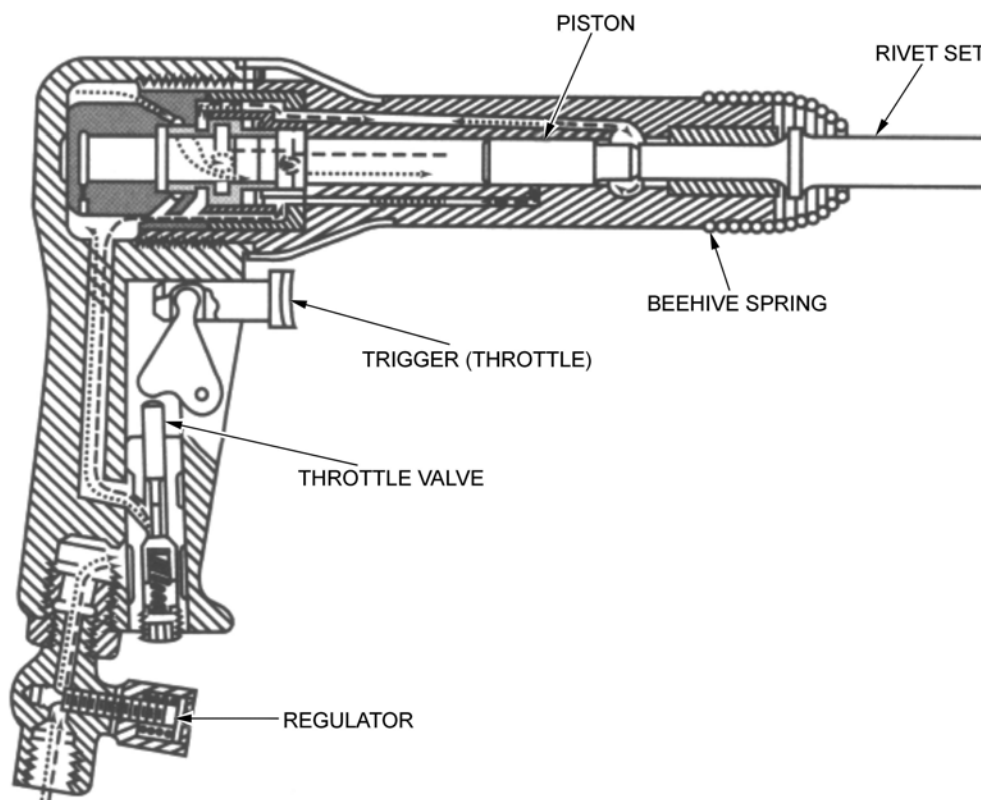
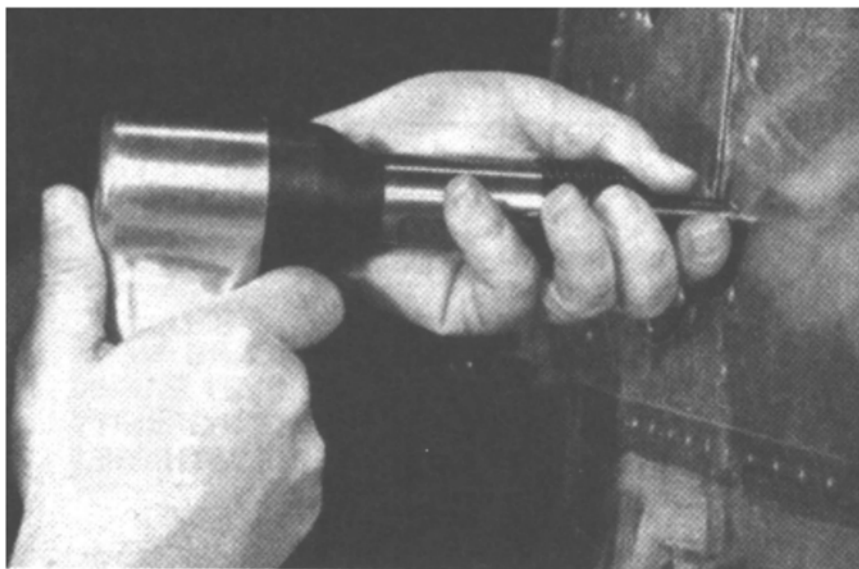

A&P Technician Airframe Textbook, Sanderson Training Systems (pp. 2-63 and 2-66)

Figure 17S-1 Rivet Gun

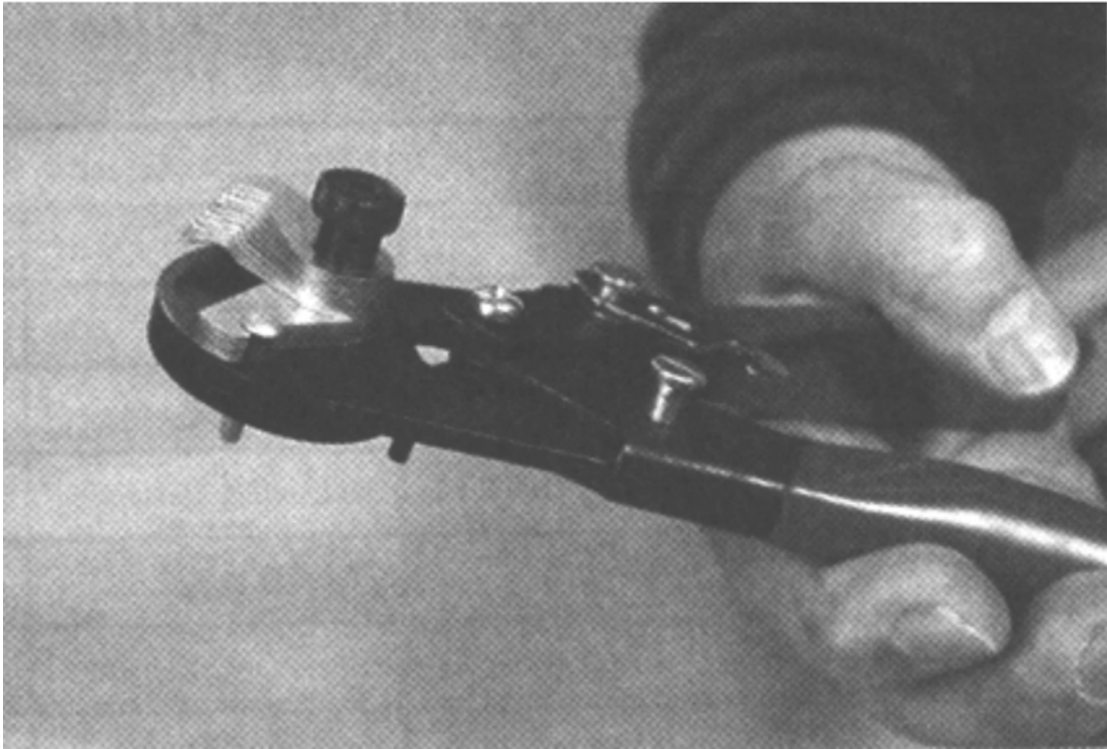

A&P Technician Airframe Textbook, Sanderson Training Systems (pp. 2-53)

Figure 17S-2 Rivet Cutter

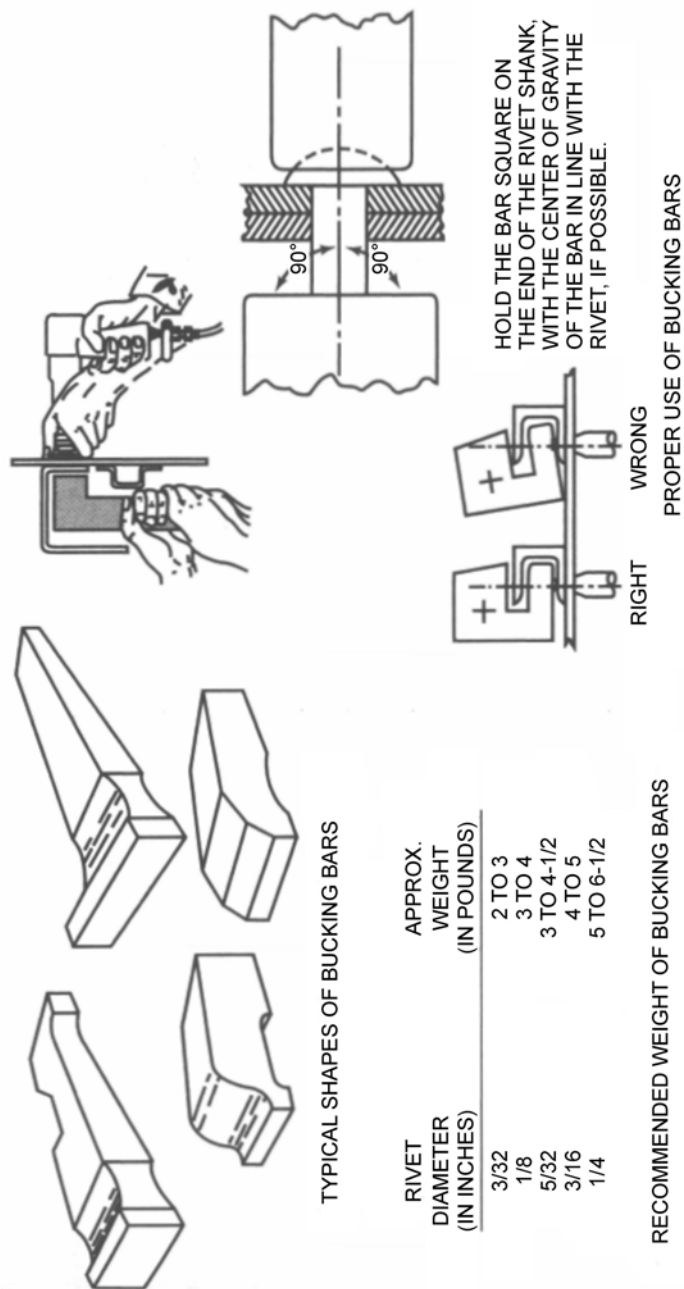

A&P Technician Airframe Textbook, Sanderson Training Systems (pp. 2-65)

Figure 17S-3 Bucking Bars

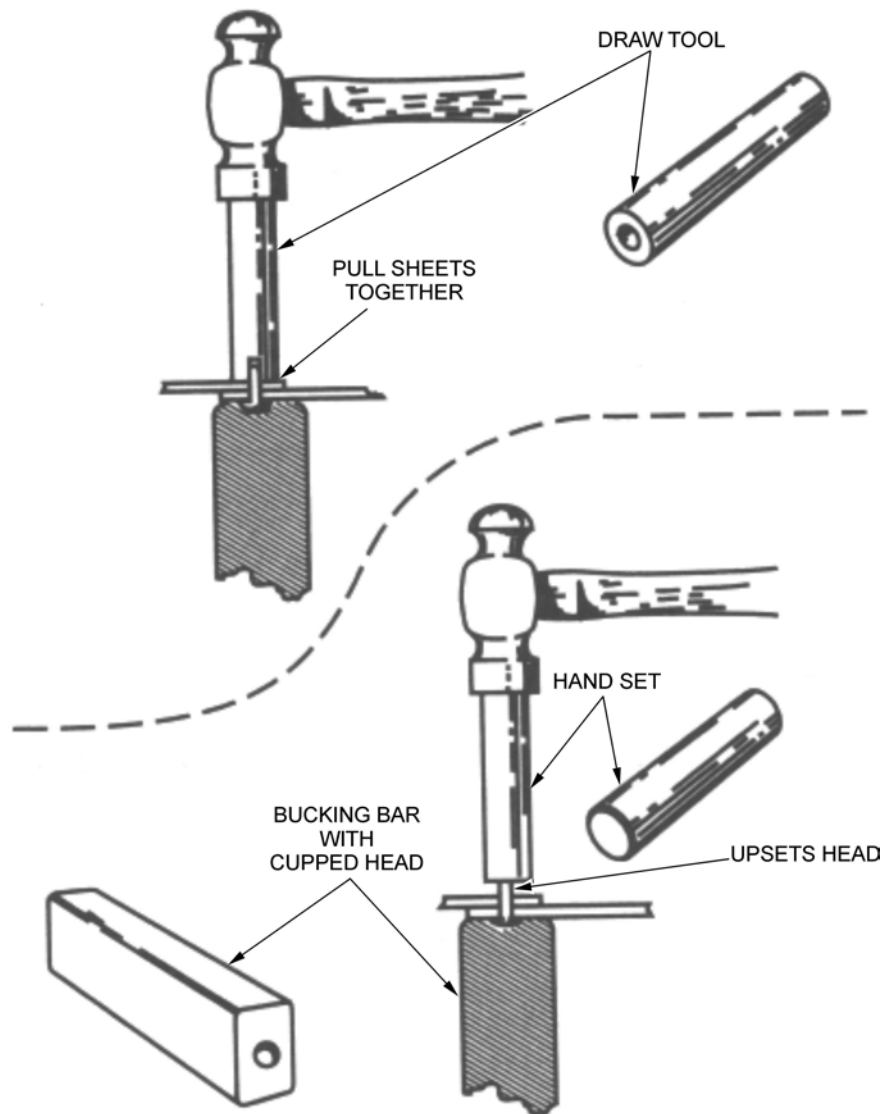

A&P Technician Airframe Textbook, Sanderson Training Systems (pp. 2-61)

Figure 17S-4 Hand Riveting

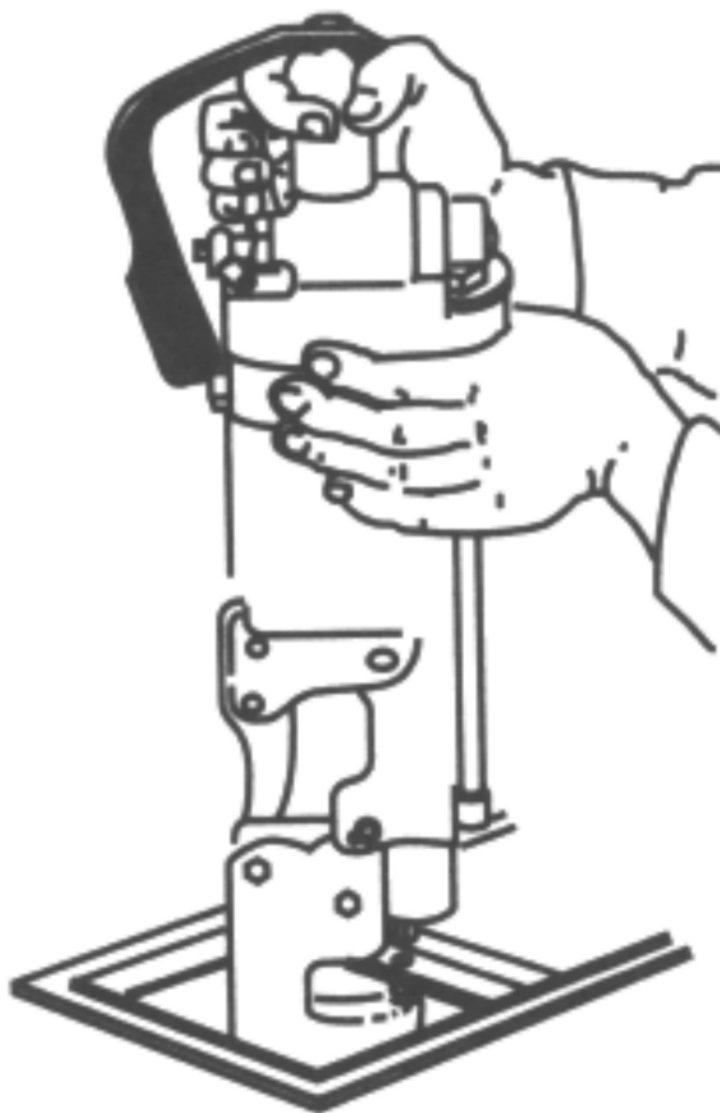

A&P Technician Airframe Textbook, Sanderson Training Systems (pp. 2-61)

Figure 17S-5 Squeezer

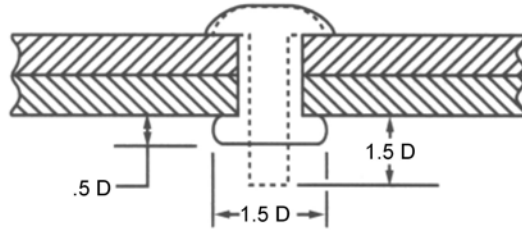

WHEN DRIVEN RIVET SWELLS TO THE SIZE OF THE DRILL HOLE

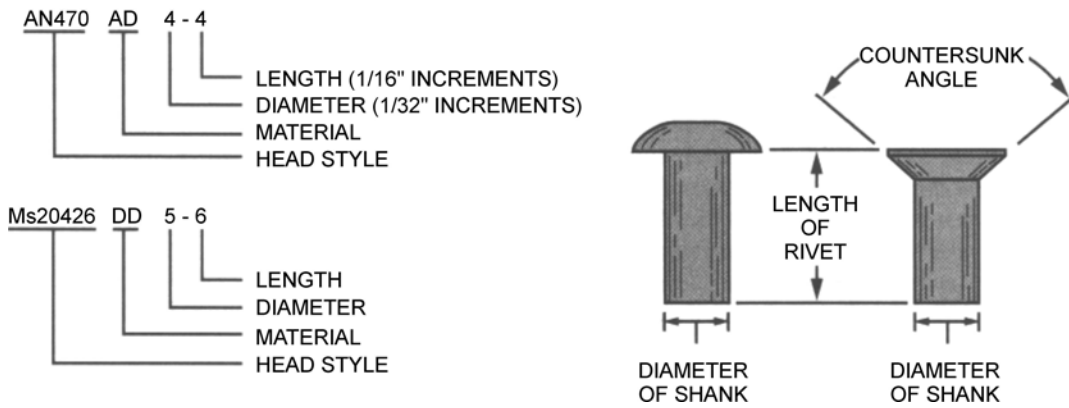

A&P Technician Airframe Textbook, Sanderson Training Systems (pp. 2-36)

Figure 17S-6 Rivet Applications, Dimensions and Designations

TOOLS AND MATERIALS REQUIRED TO CONSTRUCT AN ALUMINUM MODEL BIPLANE

Tools

- Mechanic's gloves,
- Ball-peen hammer,
- Pliers,
- Flat screwdriver,
- Rasp,
- Hand stapler,
- Staple gun,
- Push-pin,
- Hot glue gun,
- Awl,
- Wire cutters,
- Box knife,
- Scissors,
- Ruler,
- Felt-tipped pen,
- Needle-nose pliers,
- Adjustable wrench,
- Electric hand drill,
- Hole saw 2-3/4 inch bits, and
- Hole saw 1-7/8 inch bits.

Materials

- Empty aluminum beverage cans (36 per cadet),
- Softwood, 20 mm thick (fence boards),
- Bottle caps (ten per cadet),
- Corrugated cardboard,
- Poster board,
- Tape (masking),
- Glue,
- Mylar,
- Copper-coated welding rod (2 sizes 1/16 inch and 3/32 inch),

- Cap nuts or toothpaste tube caps (two per aluminum model biplane),
- Bolts, 2-1/2 inch 10-24, with nuts (four per aluminum model biplane),
- Bolts, 3-1/2 inch 10-24, with nuts (eight per aluminum model biplane), and
- Wire clip (speed nut) to fit the copper coated welding rod (two per aluminum model biplane).

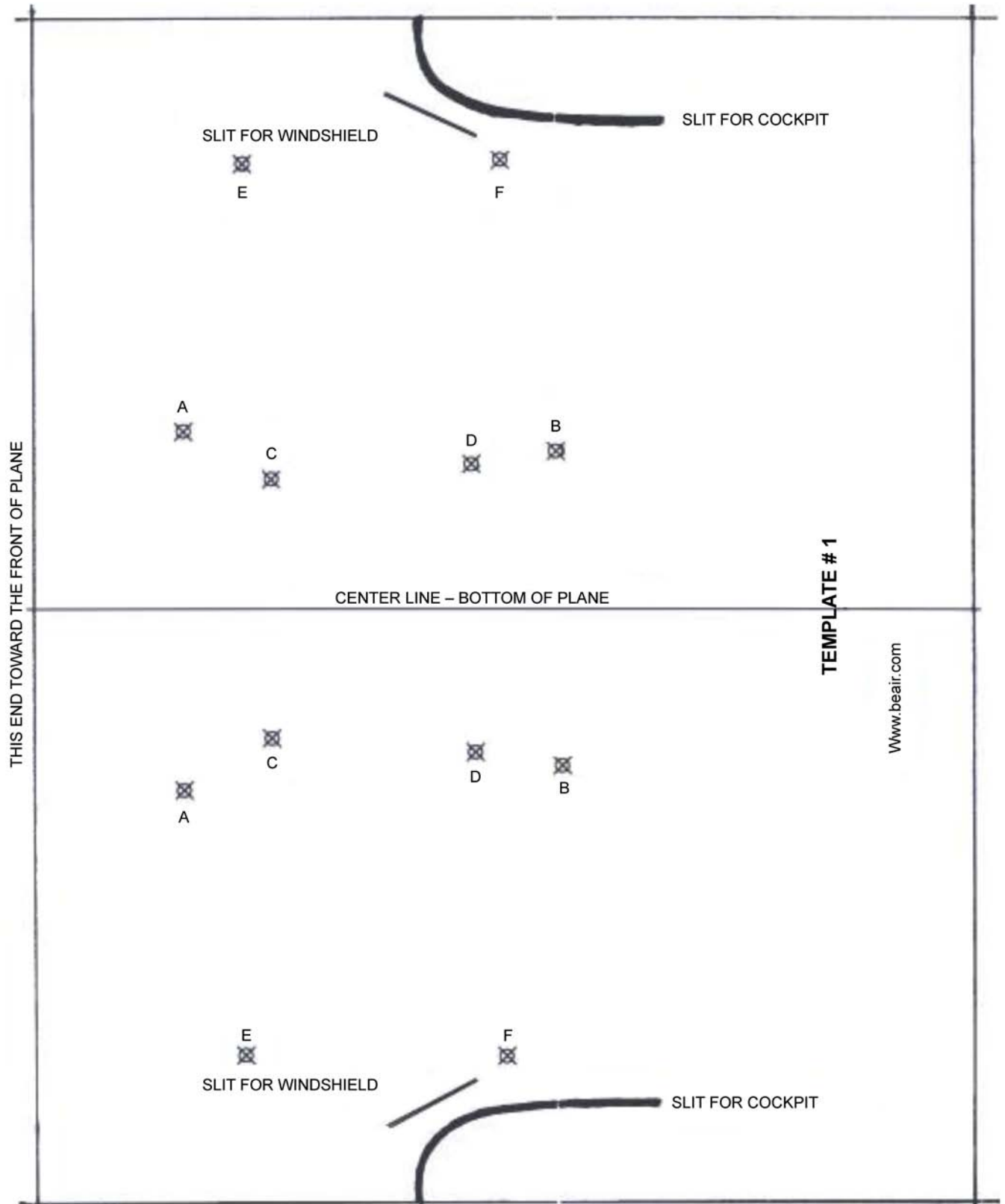

D. P. Mathis, Building the B.C. Air Originals Biplane, B.C. Air Originals (p. 3)

Figure 17T-1 Fuselage Template

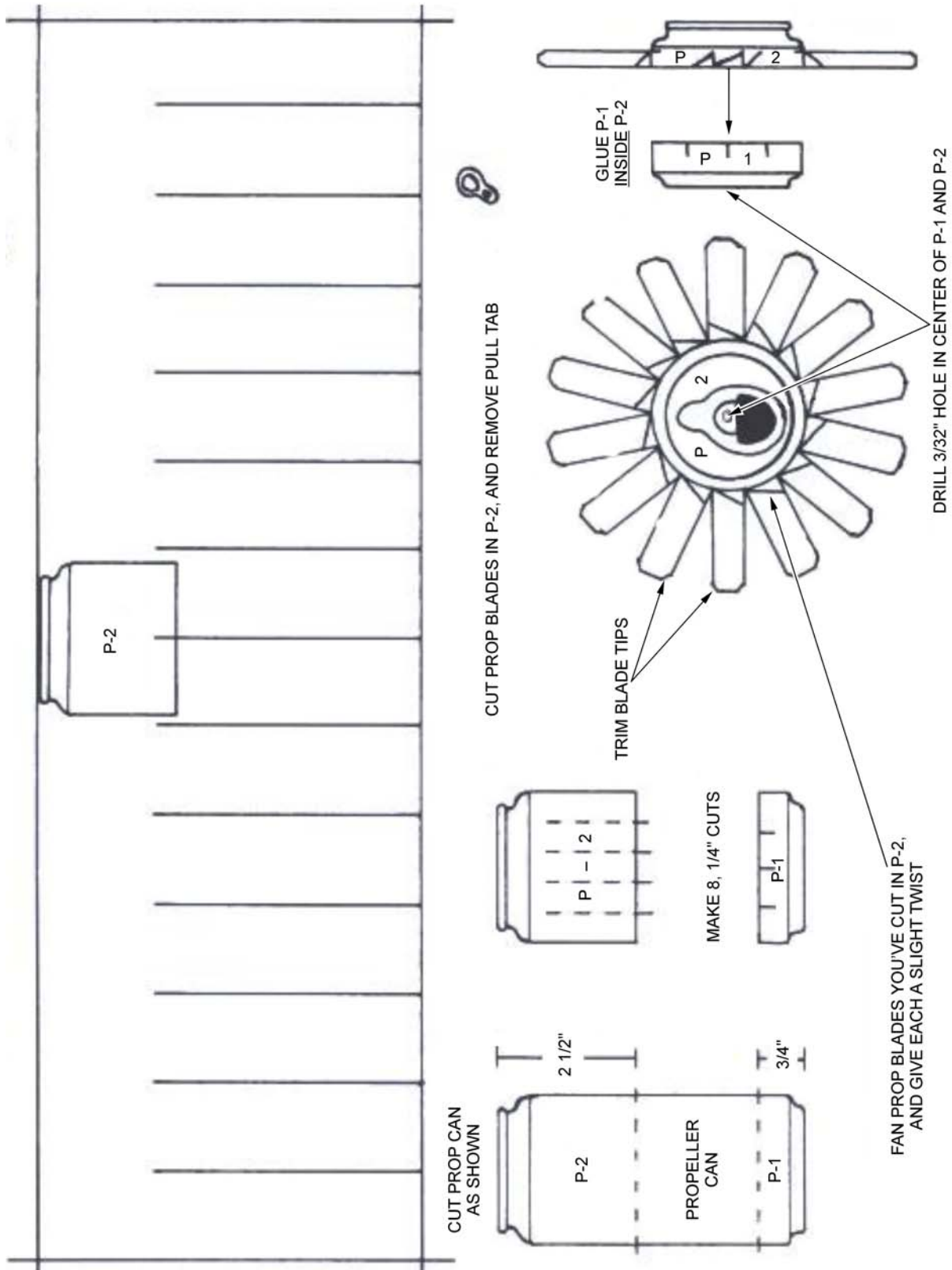

D. P. Mathis, *Building the B.C. Air Originals Biplane*, B.C. Air Originals (p. 21)

Figure 17T-2 Fuselage Template

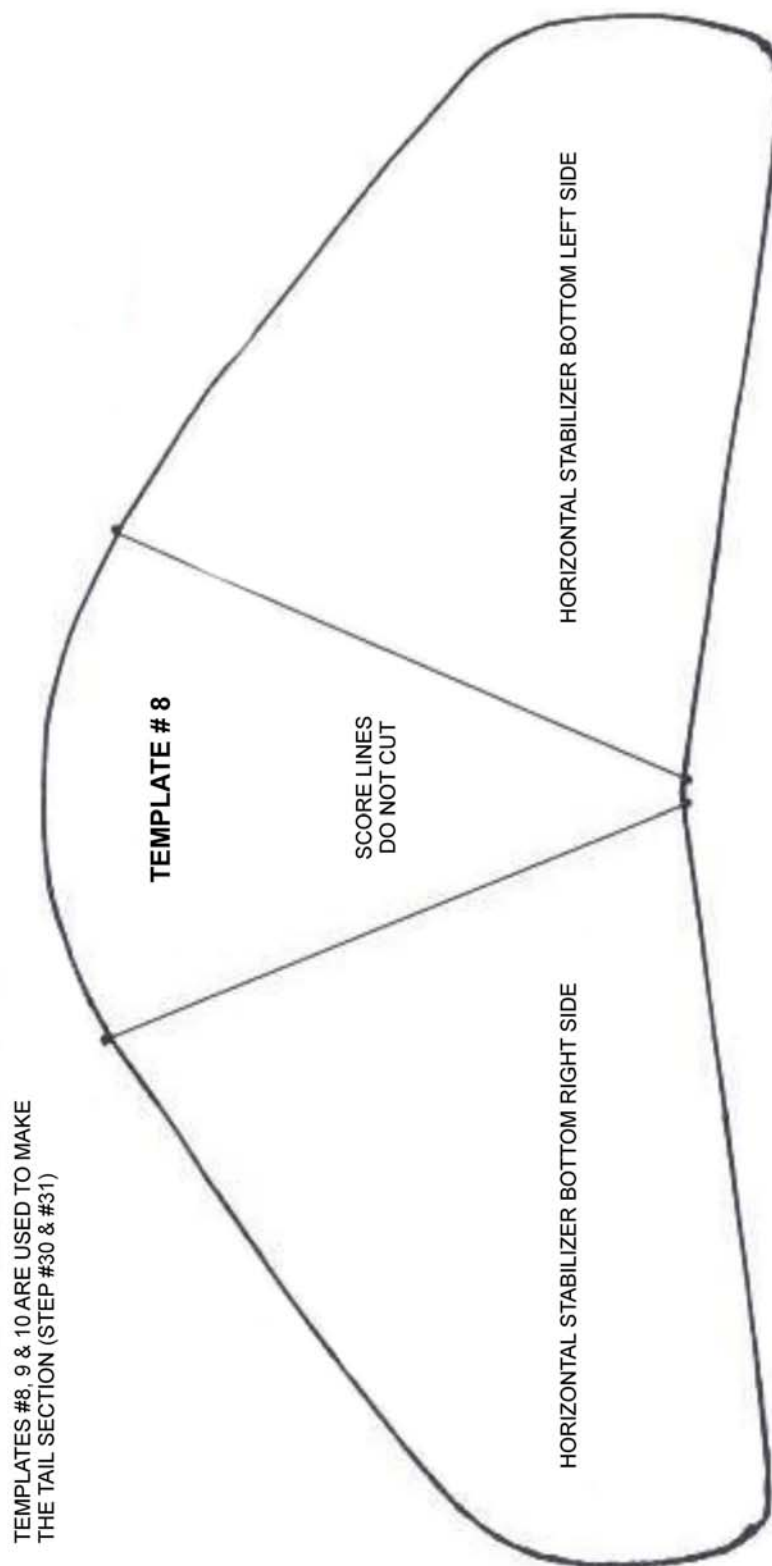

D. P. Mathis, *Building the B.C. Air Originals Biplane*, B.C. Air Originals (p. 20)

Figure 17T-3 Horizontal Stabilizer Bottom Template

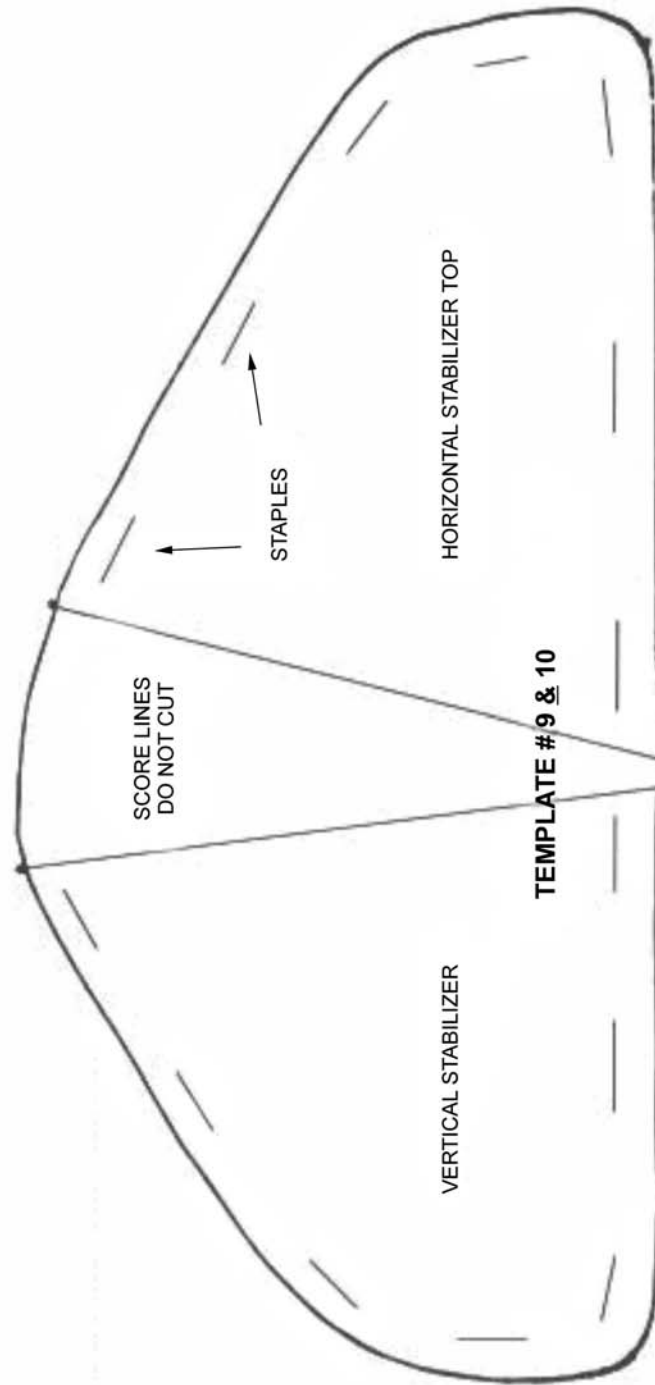

D. P. Mathis, Building the B.C. Air Originals Biplane, B.C. Air Originals (p. 20)

Figure 17T-4 Left and Right Vertical Stabilizer Template

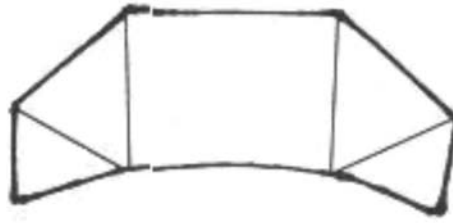

D. P. Mathis, Building the B.C. Air Originals Biplane, B.C. Air Originals (p. 20)

Figure 17T-5 Windshield Template

THIS PAGE INTENTIONALLY LEFT BLANK

RAW ALUMINUM MATERIAL ASSEMBLY LINE

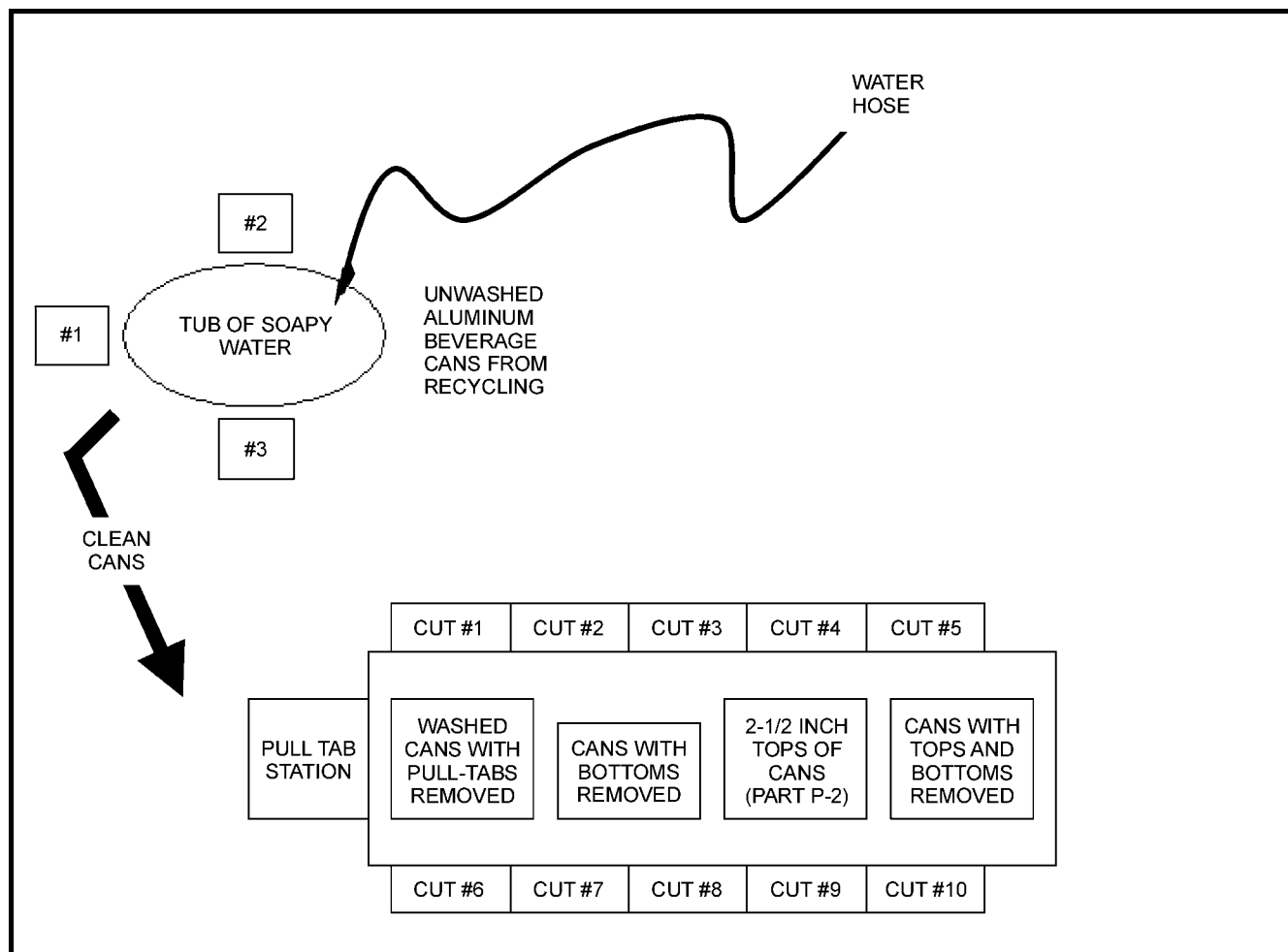

Director Cadets 3, 2007, Ottawa, ON: Department of National Defence

Figure 17U-1 Raw Aluminum Material Assembly Line

1. Wash 17 cans.
2. Remove pull-tabs from all cans.
3. Cut tops and bottoms from 15 cans using box knives (to stock as raw material) (Figure 17U-2).
4. Cut bottom from one can (can B-1 to stock for fuselage) (Figure 17U-3).
5. Cut one 2-1/2-inch top from can for propeller (can-top P2 to stock) (Figure 17U-4).
6. Cut one 3/4-inch bottom from can for propeller cover (can bottom P1 to stock).



D. P. Mathis, Building the B.C. Air Originals Biplane, B.C. Air Originals (p. 5)
Figure 17U-2 Unended Can



D. P. Mathis, Building the B.C. Air Originals Biplane, B.C. Air Originals (p. 5)
Figure 17U-3 Bottomless Can



D. P. Mathis, Building the B.C. Air Originals Biplane, B.C. Air Originals (p. 5)

Figure 17U-4 Can Top P-2

THIS PAGE INTENTIONALLY LEFT BLANK

WOOD ASSEMBLY LINE

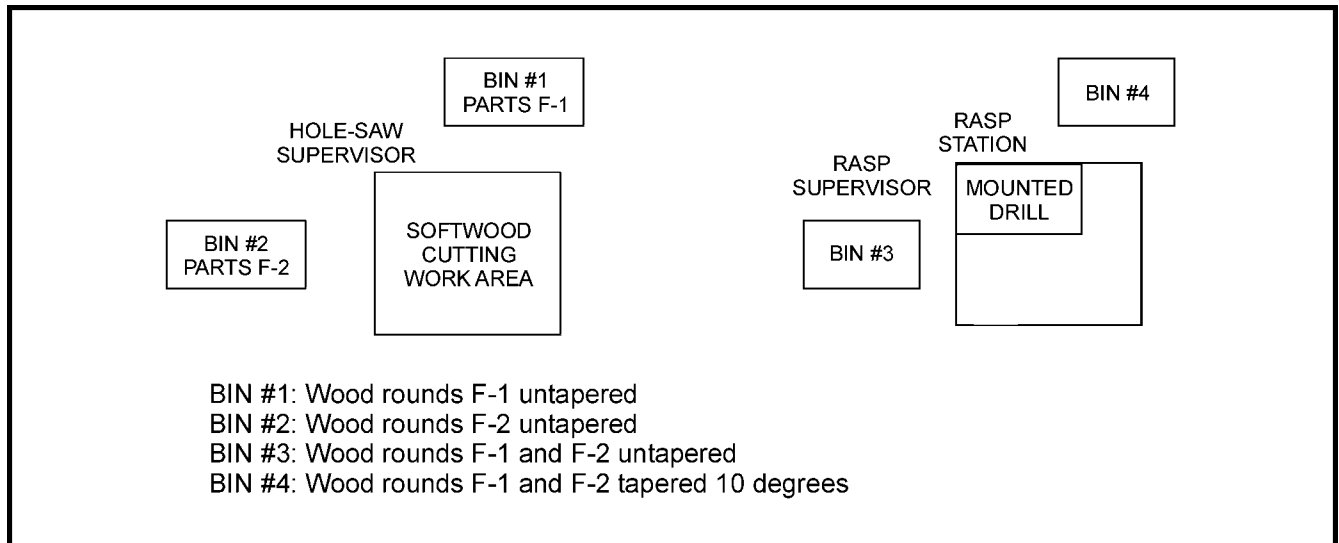

Director Cadets 3, 2007, Ottawa, ON: Department of National Defence

Figure 17V-1 Wood Assembly Line

For each aluminum model biplane to be constructed:

1. Cut one 3/4 inch thick softwood round 2-1/2 inch diameter for F-1.
2. Cut one 3/4 inch thick softwood round 1-5/8 inch diameter for F-2.
3. Place bolt through hole in centre of wood round.
4. Place nut on bolt and tighten.
5. Place bolt with wood round in electric drill.
6. Use the drill to spin the wood round (F-1) and use the rasp to taper the edge to 10 degrees (to stock as F-1).
7. Use the drill to spin the wood round (F-2) and use the rasp to taper the edge to 10 degrees (to stock as F-2).

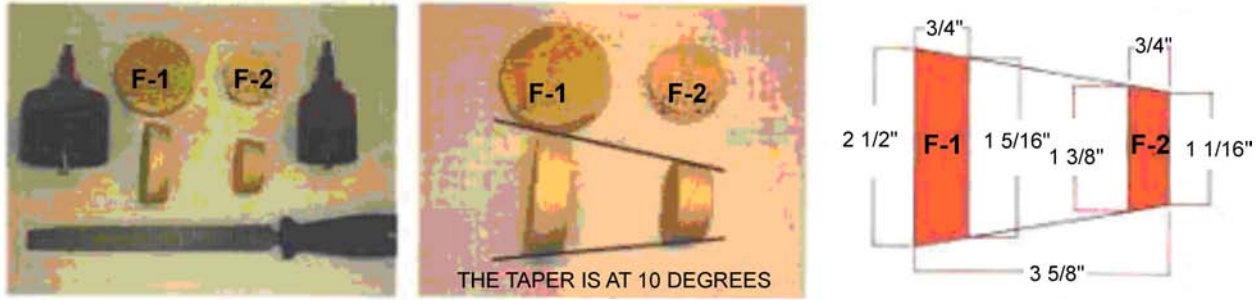

D. P. Mathis, Building the B.C. Air Originals Biplane, B.C. Air Originals (p. 4)

Figure 17V-2 Steps to Make Rear Fuselage Parts

ALUMINUM BILLET ASSEMBLY LINE

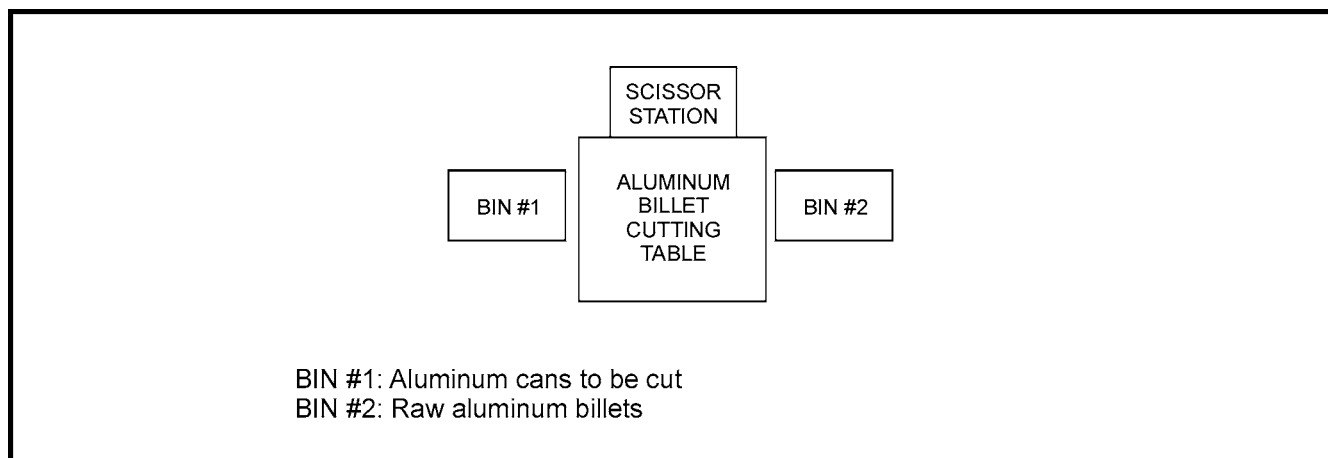

Director Cadets 3, 2007, Ottawa, ON: Department of National Defence

Figure 17W-1 Aluminum Billet Assembly Line

For each aluminum model biplane to be constructed:

1. Cut 15 unended cans vertically through the nutrition label.
2. Do not attempt to flatten cans (to stock as raw billets).

THIS PAGE INTENTIONALLY LEFT BLANK

ALUMINUM PANEL SHEARING ASSEMBLY LINE

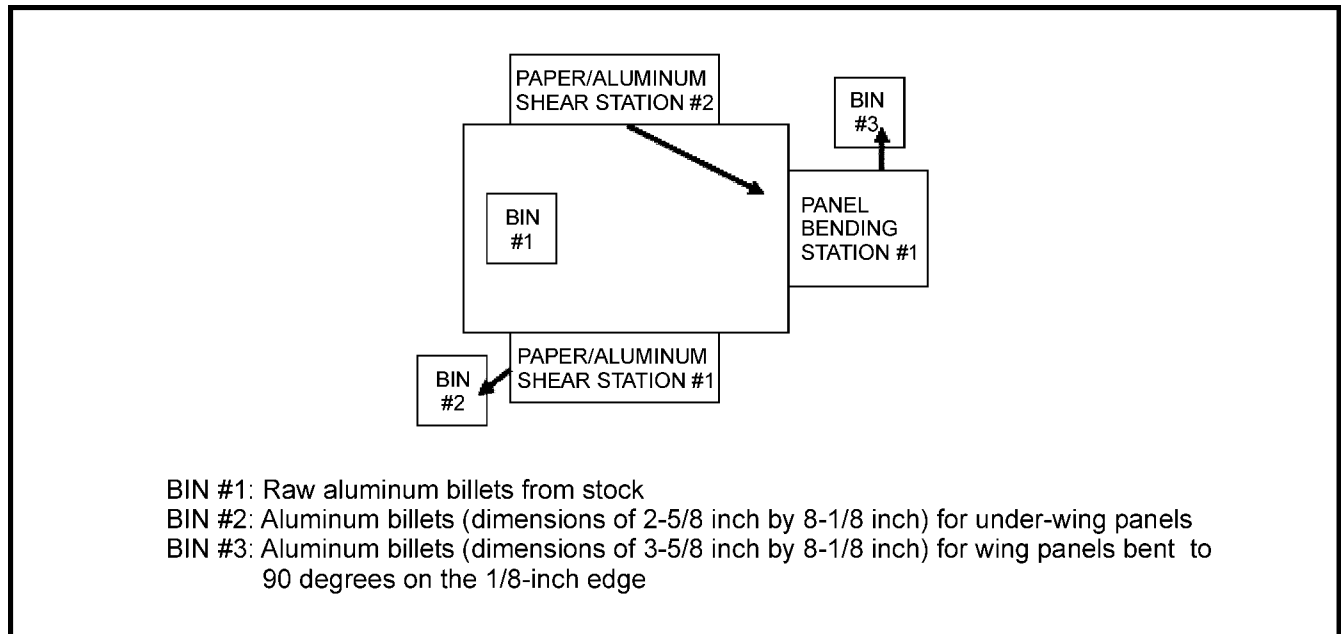

Director Cadets 3, 2007, Ottawa, ON: Department of National Defence

Figure 17X-1 Aluminum Panel Shearing Assembly Line

For each aluminum model biplane to be constructed:

1. Cut five billets to dimensions of 3-5/8 inch by 8-1/8 inch for wing panels (Figure 17X-2).
2. Bend these wing panels edges down 90 degrees on each 8-1/8 inch edge (to stock).
3. Cut five cans to dimensions of 2-5/8 inch by 8-1/8 inch for under-wing panels (Figure 17X-3) (to stock).



D. P. Mathis, Building the B.C. Air Originals Biplane, B.C. Air Originals (p. 5)

Figure 17X-2 Wing Top Panels



D. P. Mathis, Building the B.C. Air Originals Biplane, B.C. Air Originals (p. 5)

Figure 17X-3 Under-Wing Panels

CARDBOARD INSERT ASSEMBLY LINE

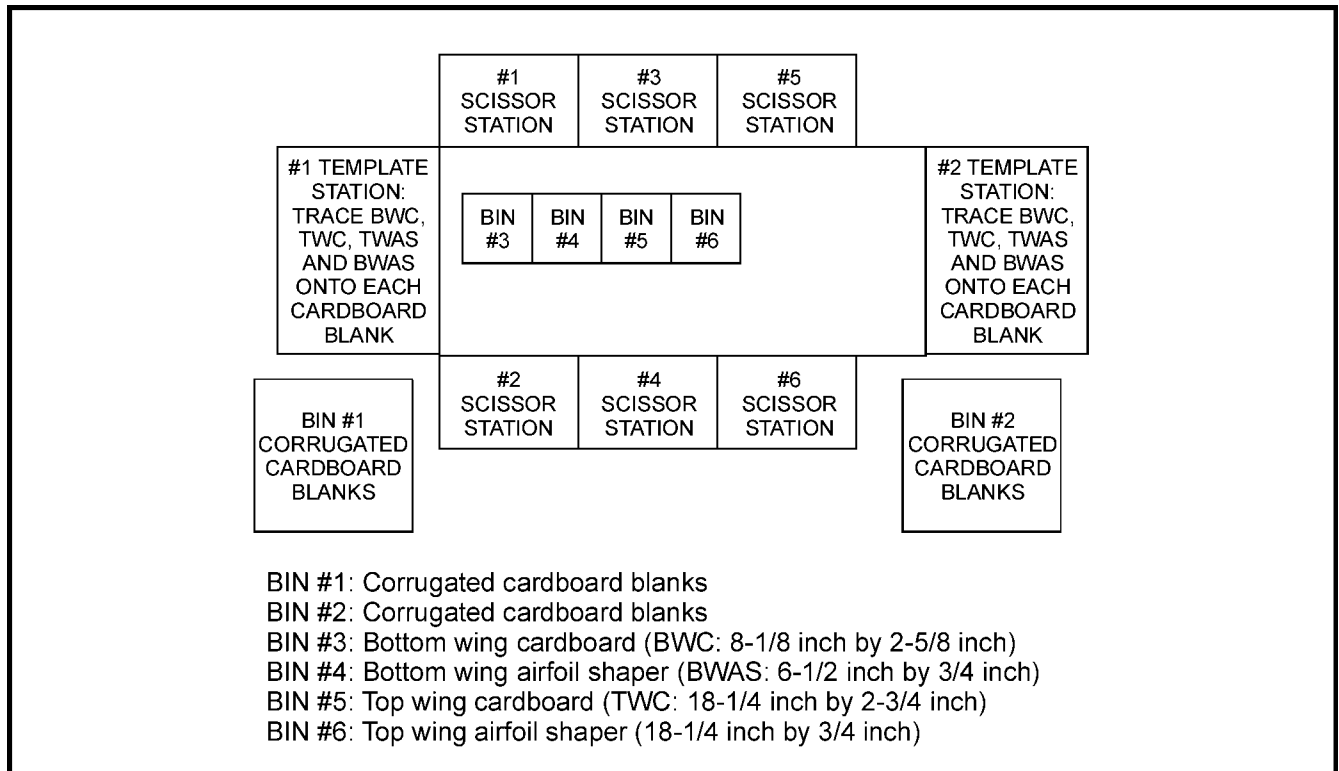

Director Cadets 3, 2007, Ottawa, ON: Department of National Defence

Figure 17Y-1 Cardboard Insert Assembly Line

For each aluminum model biplane to be constructed, cut and place into stock:

1. two bottom wing cardboard sections (BWC) 8-1/8 inch by 2-5/8 inch,
2. two cardboard bottom wing airfoil sections (BWAS) 6-1/2 inch by 3/4 inch,
3. two top wing cardboard sections (TWC) 18-1/4 inch by 2-3/4 inch, and
4. two cardboard top wing airfoil sections (TWAS) 18-1/4 inch by 3/4 inch.

THIS PAGE INTENTIONALLY LEFT BLANK

WIRE STATION ASSEMBLY LINE

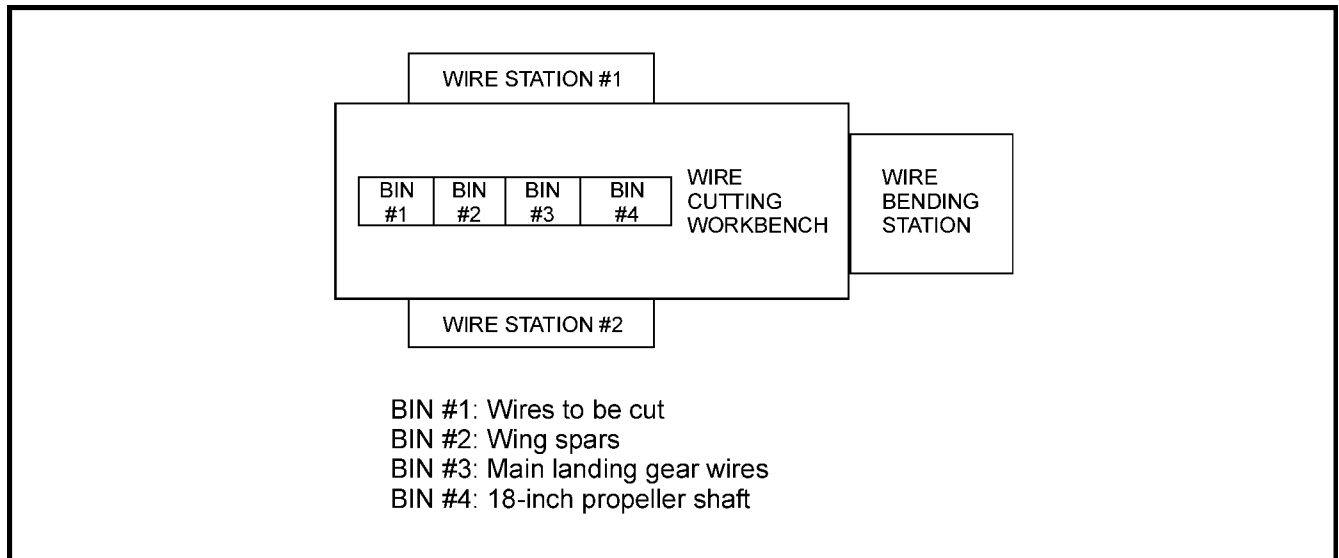

Director Cadets 3, 2007, Ottawa, ON: Department of National Defence

Figure 17Z-1 Wire Station Assembly Line

For each aluminum model biplane to be constructed:

1. Cut two pieces of 3/32-inch wire 15-3/4 inches long (to stock for wing spars).
2. Cut one piece of 3/32-inch wire 18 inches long (to stock for propeller shaft).
3. Cut one piece of 3/32-inch wire 7-3/4 inches long (for main landing gear).
4. Bend the wire that is 7-3/4 inches long to main landing gear shape (Figure 17Z-2) (to stock).

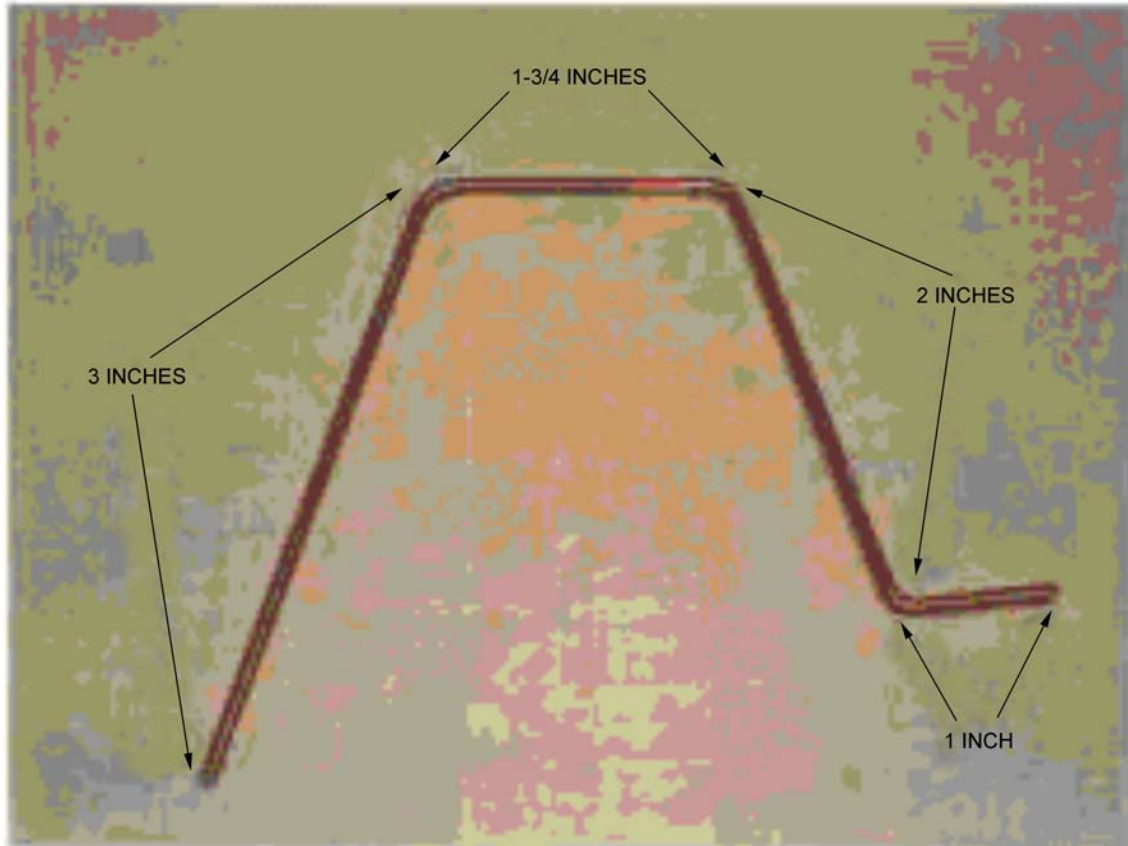

D. P. Mathis, Building the B.C. Air Originals Biplane, B.C. Air Originals (p. 15)

Figure 17Z-2 First Bends of the Landing Gear

DRILL STATION ASSEMBLY LINE

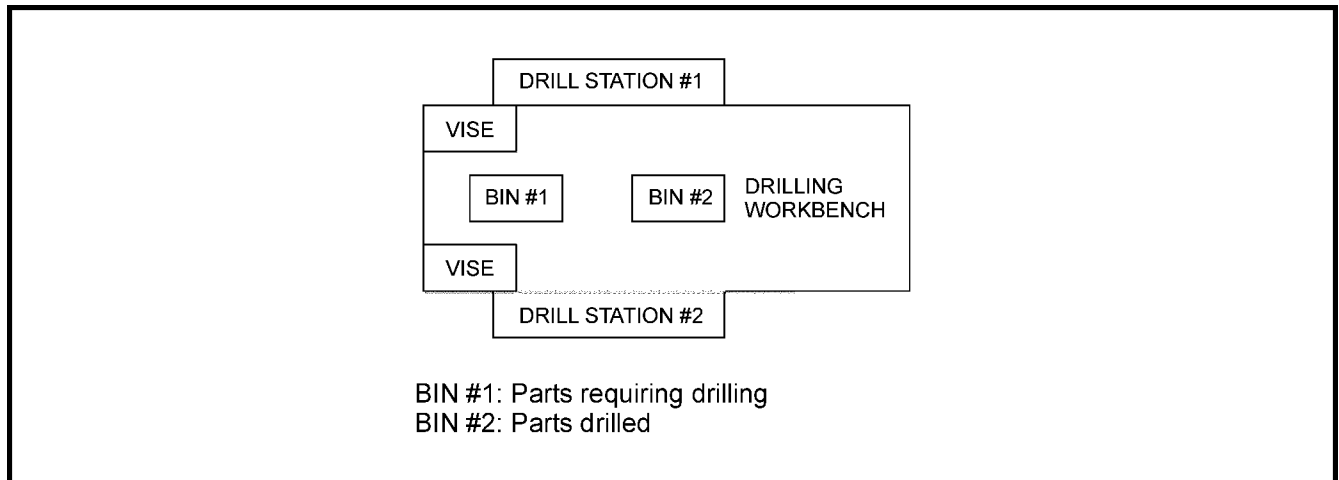

Director Cadets 3, 2007, Ottawa, ON: Department of National Defence

Figure 17AA-1 Drill Station Assembly Line

For each aluminum model biplane to be constructed:

1. Drill a 3/32-inch hole in the centre of four bottle caps (to stock for wheels).
2. Drill a 3/32-inch hole in the centre of one can B-1 (Figure 17AA-2) (to stock for front fuselage).
3. Drill a 3/32-inch hole in the centre of one can P-2 (to stock for propeller).
4. Drill a 3/32-inch hole in the centre of one can P-1 (to stock for propeller face).
5. Get fuselage from stock.
6. Enlarge holes A, B and C in fuselage assembly to 3/32 inch (fuselage from stock).
7. Enlarge hole D in fuselage assembly to 1/16 inch (fuselage from stock).
8. Enlarge holes E and F in fuselage assembly to bolt size, as required.
9. Get top wing from stock.
10. Enlarge eight bolt holes in top wing for bolts as required (return top wing to stock).
11. Get fuselage and attached bottom wing from stock.
12. Enlarge four bolt holes in bottom wing as required (return fuselage and bottom wing to stock).
13. Insert under-wing panel (dimensions 2-5/8 inch by 8-1/8 inch) into right wing.

DRILL 3/32 INCH HOLE IN CENTRE OF TOP

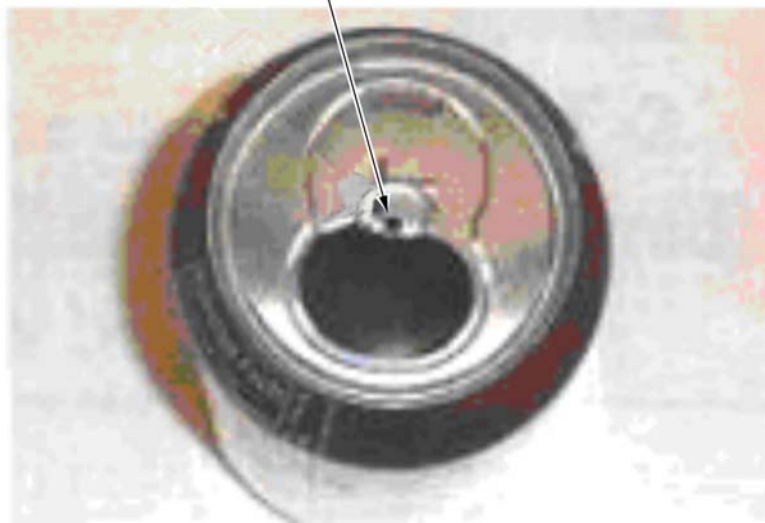

D. P. Mathis, Building the B.C. Air Originals Biplane, B.C. Air Originals (p. 5)

Figure 17AA-2 The Fuselage Centre-Line Hole

ALUMINUM REAR FUSELAGE ASSEMBLY LINE

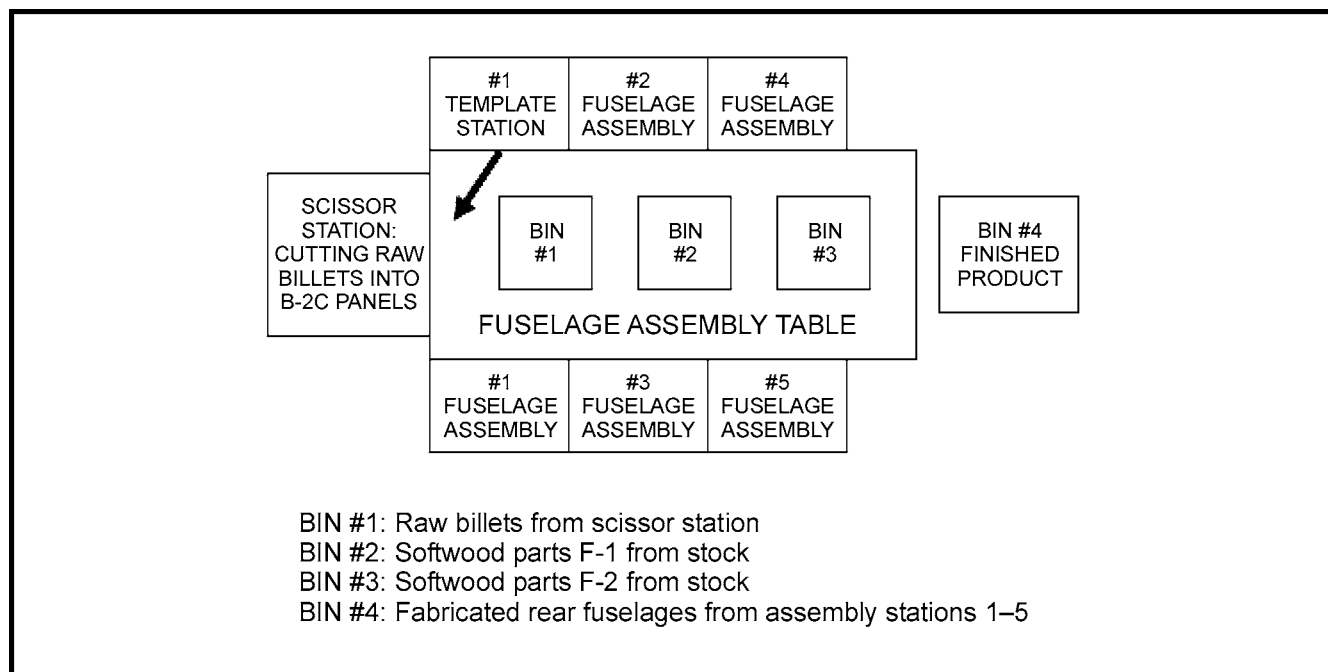

Director Cadets 3, 2007, Ottawa, ON: Department of National Defence

Figure 17AB-1 Aluminum Rear Fuselage Assembly Line

For each aluminum model biplane to be constructed:

1. Mark one raw billet as B-2C rear fuselage.
2. Cut triangle from one raw billet to create B-2C rear fuselage (Figure 17AB-2) (to stock as B-2C).
3. Combine wood F1 and F2 with B-2C and staple to make rear fuselage B-2 (Figure 17AB-3) (to stock as B-2).



D. P. Mathis, Building the B.C. Air Originals Biplane, B.C. Air Originals (p. 5)

Figure 17AB-2 Triangle Cut

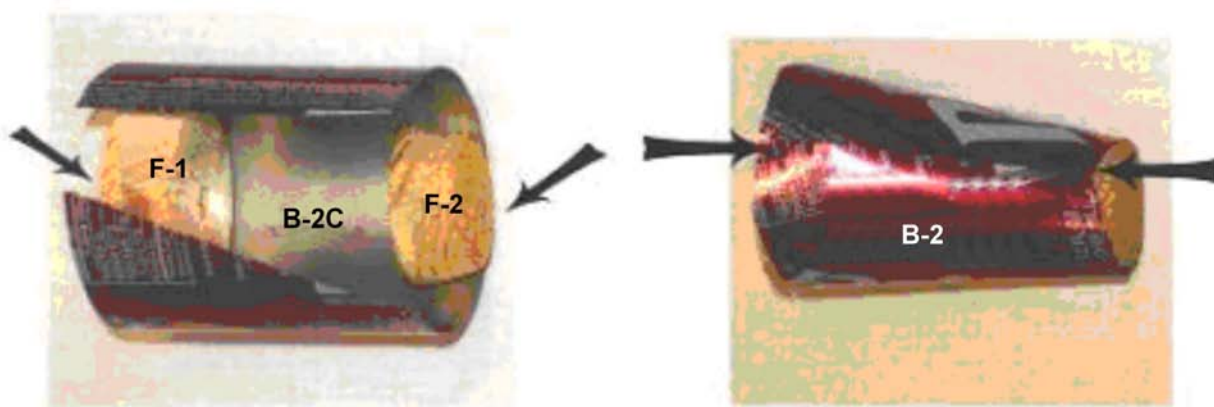

D. P. Mathis, Building the B.C. Air Originals Biplane, B.C. Air Originals (p. 6)

Figure 17AB-3 Completing the Rear Fuselage

FUSELAGE AND BOTTOM WING ASSEMBLY LINE

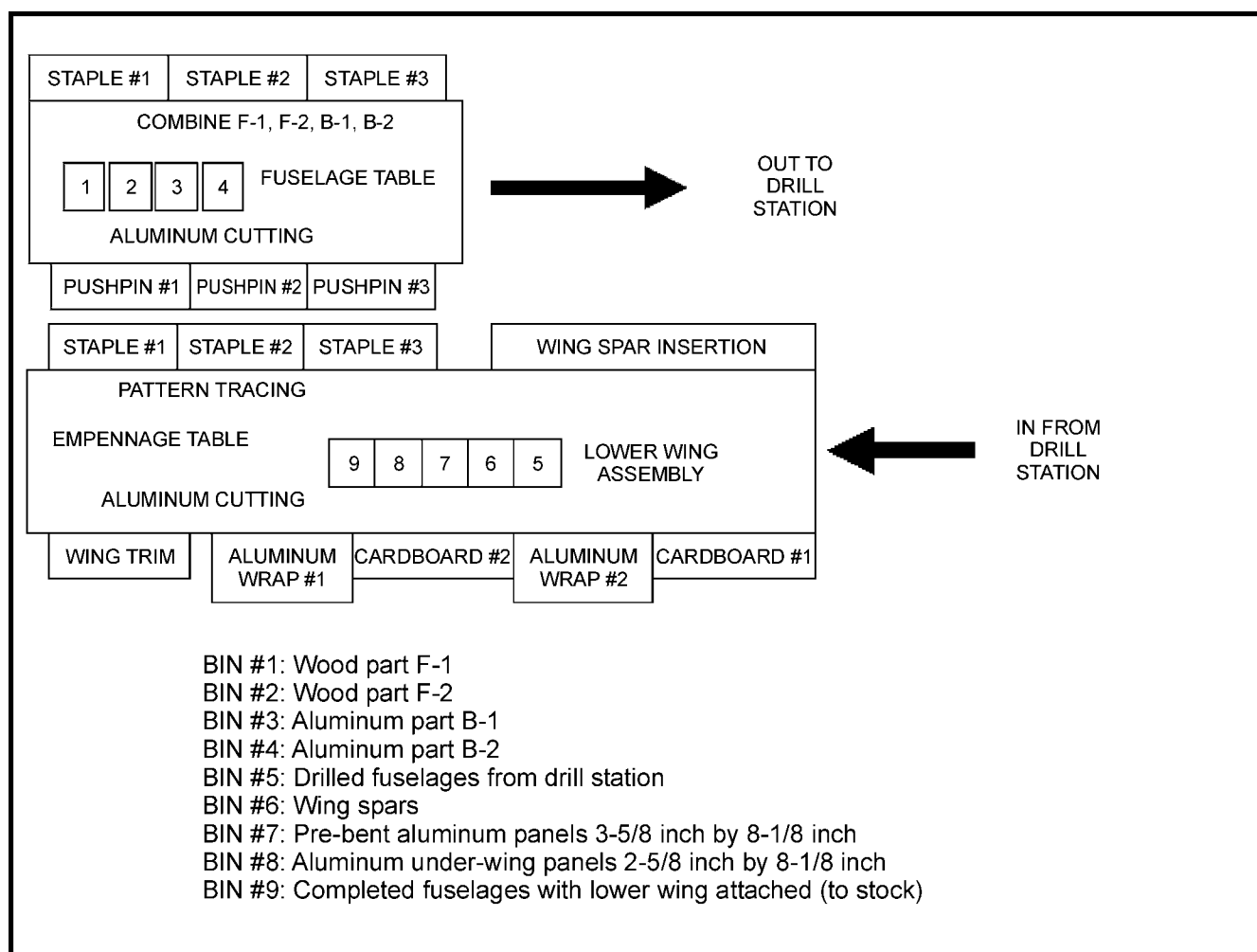

Director Cadets 3, 2007, Ottawa, ON: Department of National Defence

Figure 17AC-1 Fuselage and Bottom Wing Assembly Line

For each aluminum model biplane to be constructed:

1. Combine parts F-1, F-2, B-1 and B-2 with staples to make a full fuselage (Figure 17AC-2).
2. Slide Template No. 1 over full fuselage (Figure 17AC-3).
3. Use push-pins to create holes in fuselage through Template No. 1.
4. Trace, but do not cut, the openings for the cockpit and windshield.
5. Remove Template No. 1 from fuselage (to stock for Drill Station).
6. Insert bottom wing spars in fuselage holes A and B (spars/fuselage from stock).
7. Tape cardboard parts BWC to bottom wing spars (BWC and spars from stock) (Figure 17AC-4).
8. Tape or glue cardboard part BWAS to top of BWC (BWAS/BWC from stock).
9. Repeat Steps 7. and 8. for other wing.

10. Wrap top of left bottom wing with pre-bent aluminum panel (from stock) (Figure 17AC-5).
11. Wrap top of right bottom wing with pre-bent aluminum panel (Figure 17AC-6) (from stock).
12. Insert under-wing panel (dimensions 2-5/8 inch by 8-1/8 inch) into left wing (Figure 17AC-7).
13. Insert under-wing panel (dimensions 2-5/8 inch by 8-1/8 inch) into right wing (Figure 17AC-7).
14. Staple panels (three staples) at left wing tip (Figure 17AC-8).
15. Staple panels (three staples) at right wing tip (Figure 17AC-8).
16. Trim wing tips to desired shape.
17. Make two slits for the windshield (Figure 17AC-9).
18. Trim cockpit aluminum to avoid blocking pilot hole in F-1 (Figure 17AC-10).
19. Carefully turn biplane upside down.
20. Split cockpit back in half so it will fold down and place wire insulation on cockpit edging (Figure 17AC-11).
21. Turn the Wing Bolt Hole Placement Template (WBHPT) upside down also, and apply WBHPT to the underside of the bottom wing Figure 17AC-12).
22. With a push-pin, make holes for four outer bolts in the bottom wing near the wing tips. Do not make holes near the fuselage (fuselage with bottom wing to stock).



D. P. Mathis, Building the B.C. Air Originals Biplane, B.C. Air Originals (p. 6)

Figure 17AC-2 Fuselage Assembly



Building the B.C. Air Originals Biplane, by D. P. Mathis, B.C. Air Originals (p. 6)

Figure 17AC-3 Fuselage With Clear Mylar Template Placed Around

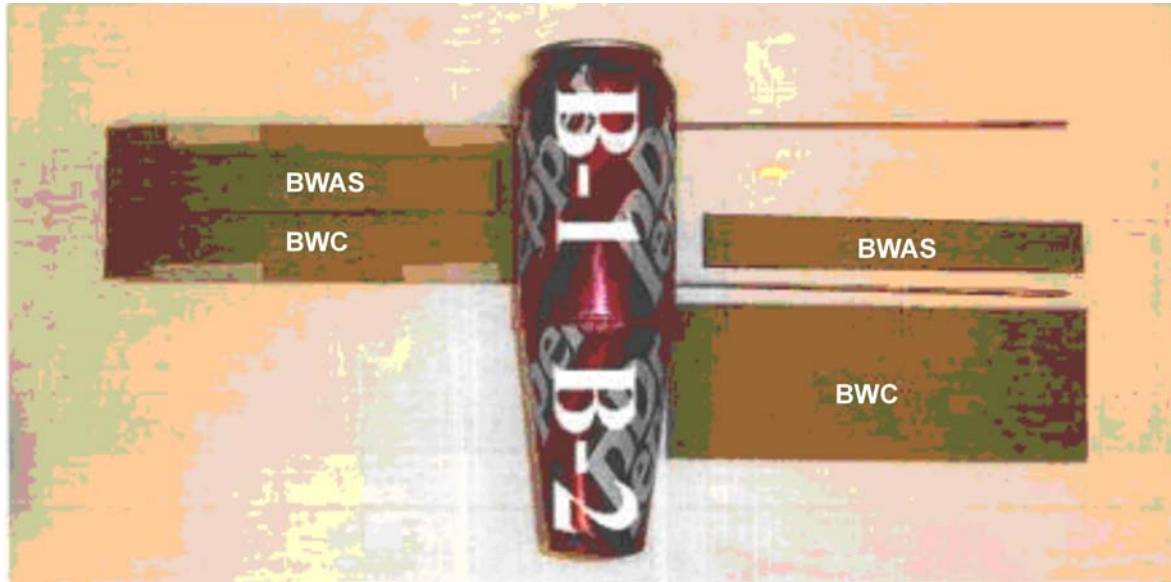

D. P. Mathis, Building the B.C. Air Originals Biplane, B.C. Air Originals (p. 7)
Figure 17AC-4 Getting Its Wings



D. P. Mathis, Building the B.C. Air Originals Biplane, B.C. Air Originals (p. 7)
Figure 17AC-5 Cladding the Wings

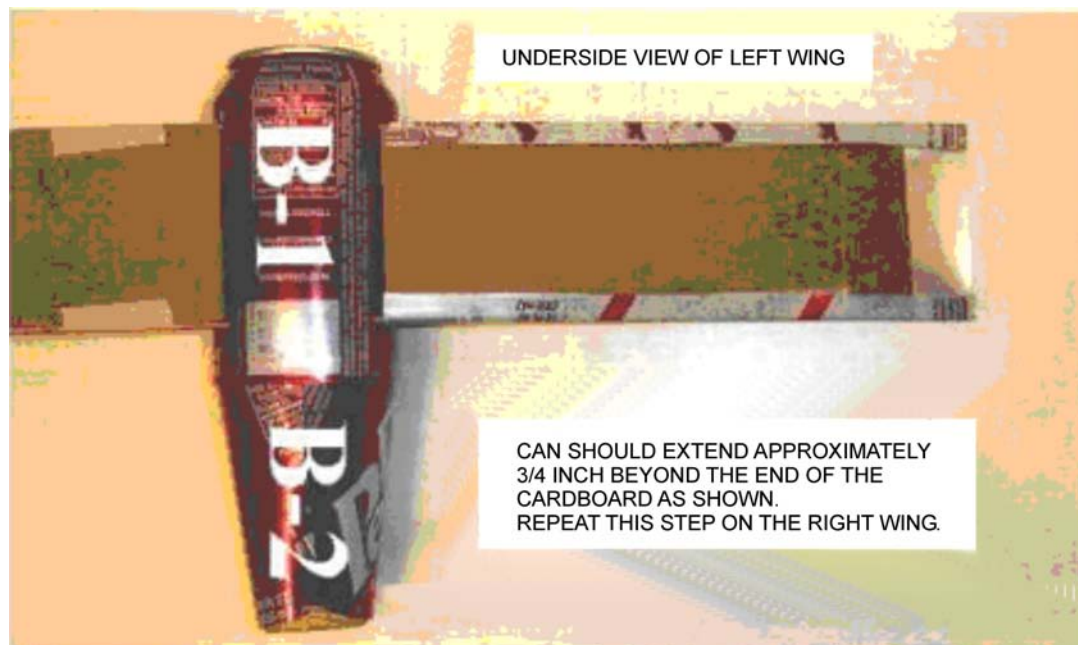

D. P. Mathis, Building the B.C. Air Originals Biplane, B.C. Air Originals (p. 8)

Figure 17AC-6 Under the Wings

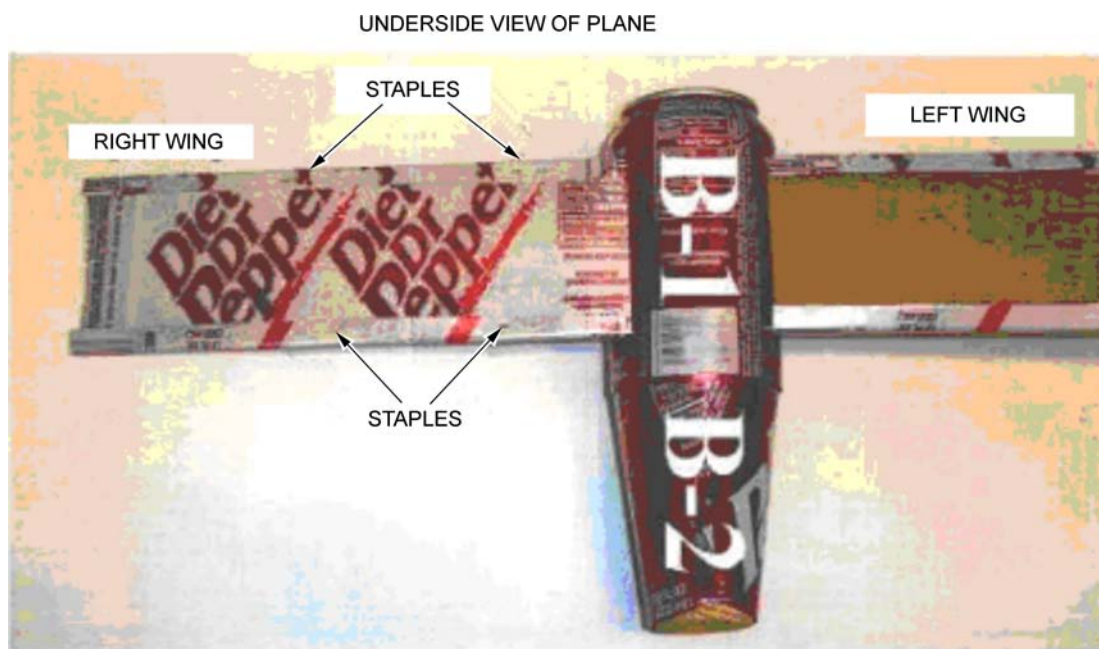

D. P. Mathis, Building the B.C. Air Originals Biplane, B.C. Air Originals (p. 8)

Figure 17AC-7 Cladding the Under-wing



D. P. Mathis, *Building the B.C. Air Originals Biplane*, *B.C. Air Originals* (p. 9)

Figure 17AC-8 Securing the Wing Tip



D. P. Mathis, *Building the B.C. Air Originals Biplane*, *B.C. Air Originals* (p. 9)

Figure 17AC-9 Roughing the Cockpit and Windscreen

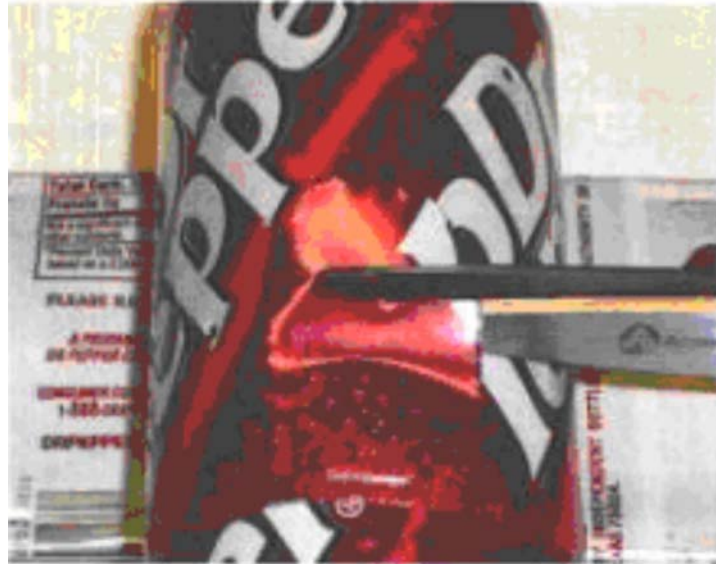

D. P. Mathis, Building the B.C. Air Originals Biplane, B.C. Air Originals (p. 10)

Figure 17AC-10 Clearing the Centre Line

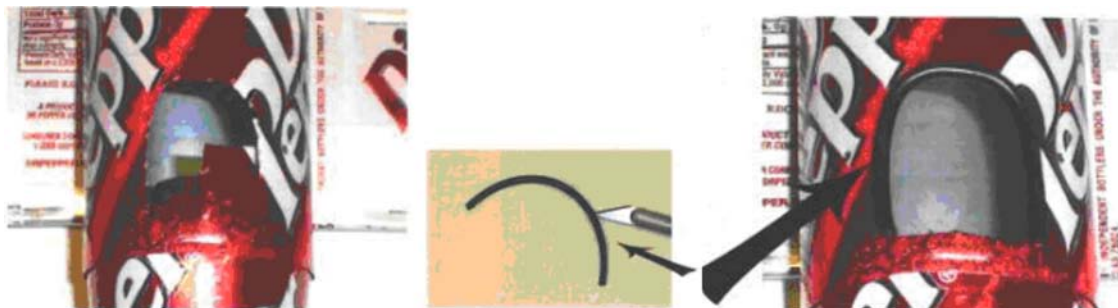

D. P. Mathis, Building the B.C. Air Originals Biplane, B.C. Air Originals (p. 10)

Figure 17AC-11 Opening and Trimming the Cockpit

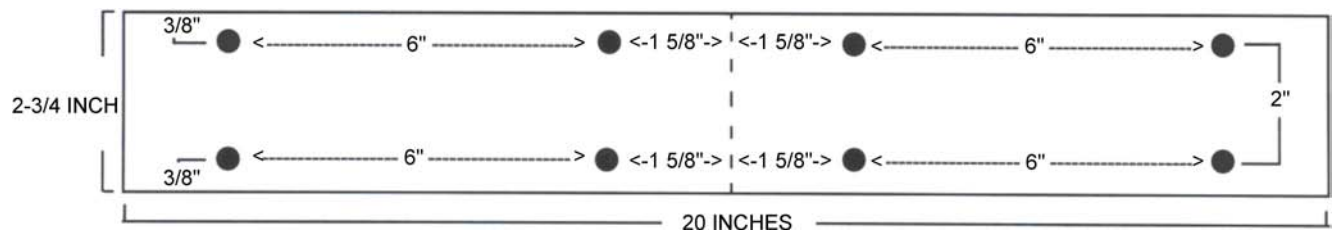

D. P. Mathis, Building the B.C. Air Originals Biplane, B.C. Air Originals (p. 12)

Figure 17AC-12 Wing Bolt Hole Placement Template (WBHPT)

THIS PAGE INTENTIONALLY LEFT BLANK

TOP WING ASSEMBLY LINE

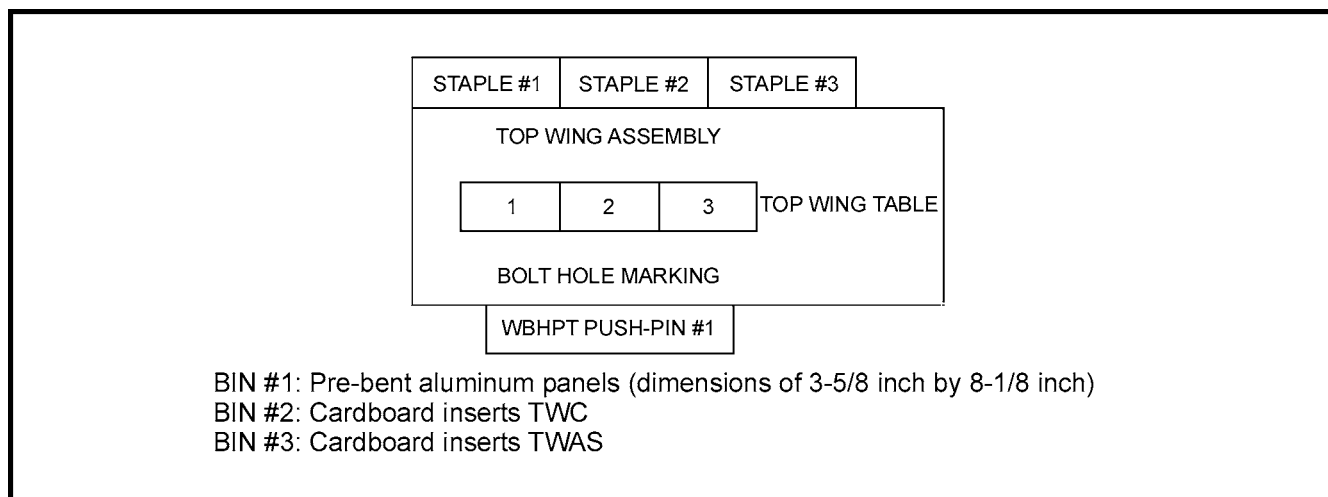

Director Cadets 3, 2007, Ottawa, ON: Department of National Defence

Figure 17AD-1 Top Wing Assembly Line

For each aluminum model biplane to be constructed:

1. Combine cardboard parts TWC, TWAS and three pre-bent aluminum panels (dimensions of 3-5/8 inch by 8-1/8 inch) to form top wing (all from stock).
2. Insert panels (dimensions of 2-5/8 inch by 8-1/8 inch) under wing (from stock).
3. Staple top wing (ten staples).
4. Apply Wing Bolt Hole Placement Template (WBHPT) to top of top wing and with a push-pin, make eight holes for bolts in the top wing (top wing to stock).

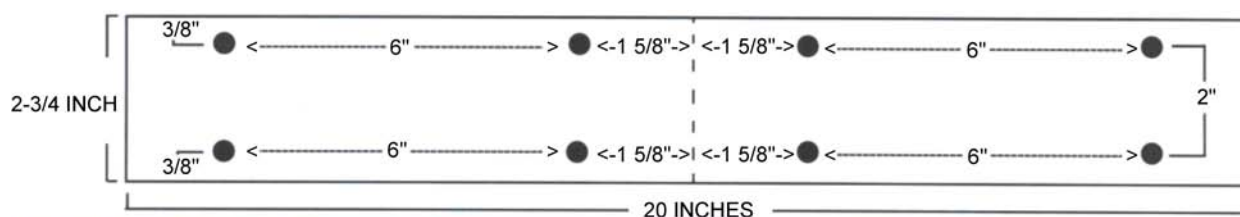

D. P. Mathis, Building the B.C. Air Originals Biplane, B.C. Air Originals (p. 12)

Figure 17AD-2 Wing Bolt Hole Placement Template (WBHPT)

THIS PAGE INTENTIONALLY LEFT BLANK

EMPENNAGE ASSEMBLY LINE

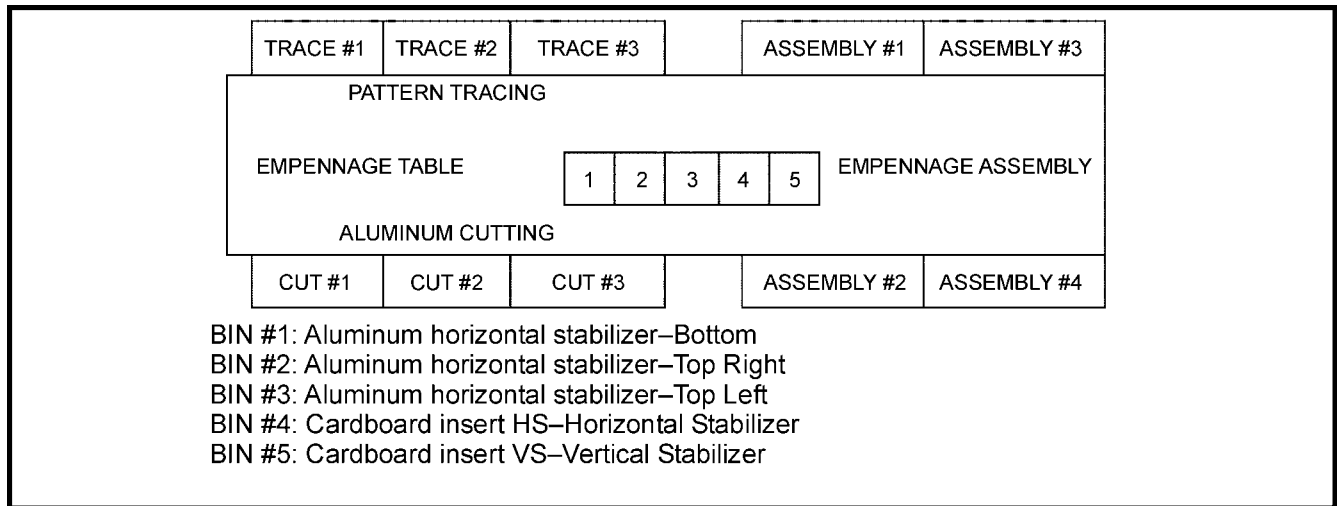

Director Cadets 3, 2007, Ottawa, ON: Department of National Defence

Figure 17AE-1 Empennage Assembly Line

For each aluminum model biplane to be constructed:

1. Trace Template No. 8 onto one raw aluminum billet (from stock).
2. Cut with scissors (Figure 17AE-2).
3. Trace Template No. 9 onto one raw aluminum billet (from stock).
4. Cut with scissors one horizontal stabilizer top right (Template No. 9) (Figure 17AE-2).
5. Trace Template No. 10 onto one raw aluminum billet (from stock).
6. Cut with scissors one horizontal stabilizer top left (Template No. 10) (Figure 17AE-2).
7. Score one horizontal stabilizer bottom (Template No. 8).
8. Score one horizontal stabilizer top right (Template No. 9).
9. Score one horizontal stabilizer top left (Template No. 10).
10. Combine cardboard pieces HS and VS with aluminum parts (Figure 17AE-3), to include:
 - a. one scored horizontal stabilizer bottom (Template No. 8),
 - b. one scored horizontal stabilizer top right (Template No. 9), and
 - c. one scored horizontal stabilizer top left (Template No. 10).
11. Carefully bend the aluminum parts to form a complete empennage (Figure 17AE-4).
12. Staple the complete empennage.

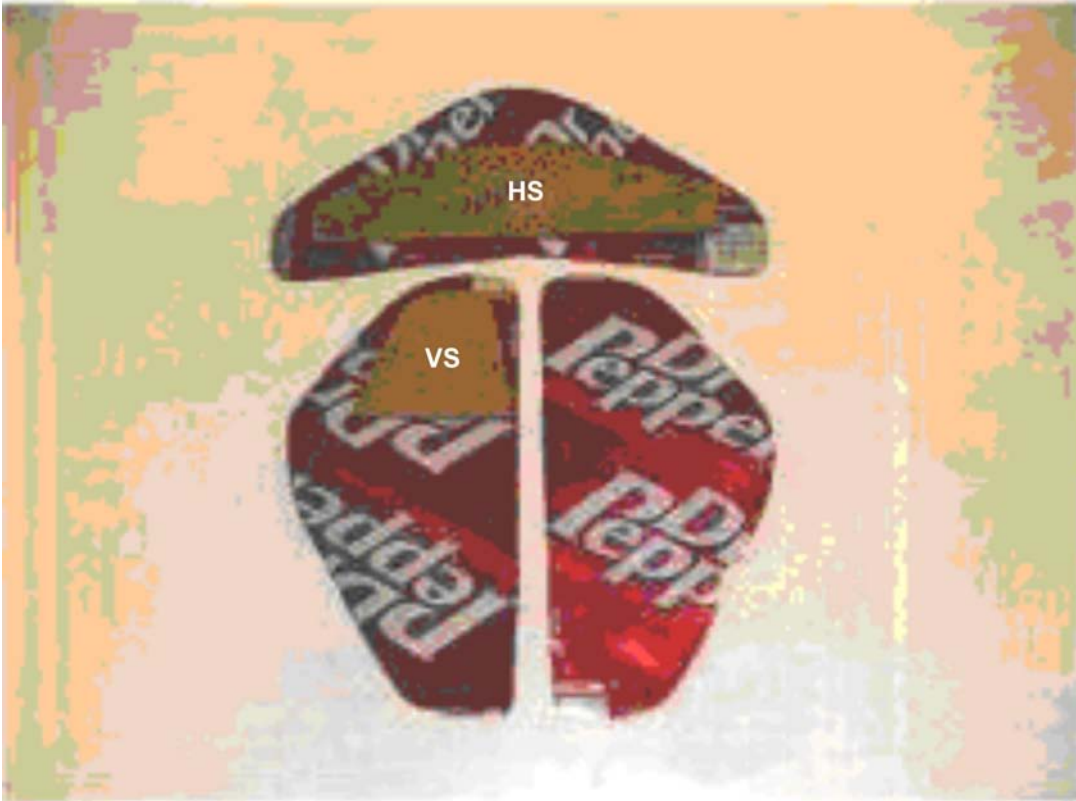

D. P. Mathis, Building the B.C. Air Originals Biplane, B.C. Air Originals (p. 16)

Figure 17AE-2 Parts of the Empennage

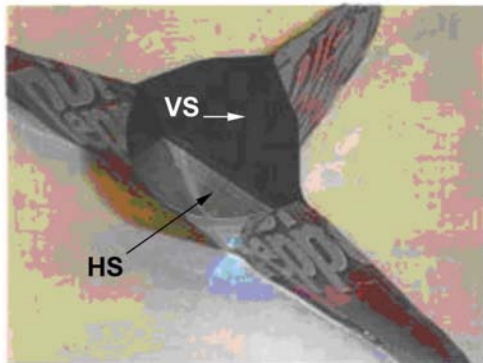

D. P. Mathis, Building the B.C. Air Originals Biplane, B.C. Air Originals (p. 16)

Figure 17AE-3 Forming the Empennage

Match up the left and right Vertical Stabilizer parts and staple them together, placing staples approximately 3/8 inch from the outside edge. Insert cardboard VS between the two Vertical Stabilizer halves.

Match up the Horizontal Stabilizer parts and staple only the back end together. Insert the cardboard HS between the Horizontal Stabilizer panels.



D. P. Mathis, Building the B.C. Air Originals Biplane, B.C. Air Originals (p. 16)

Figure 17AE-4 Forming the Empennage

THIS PAGE INTENTIONALLY LEFT BLANK

PROPELLER ASSEMBLY LINE

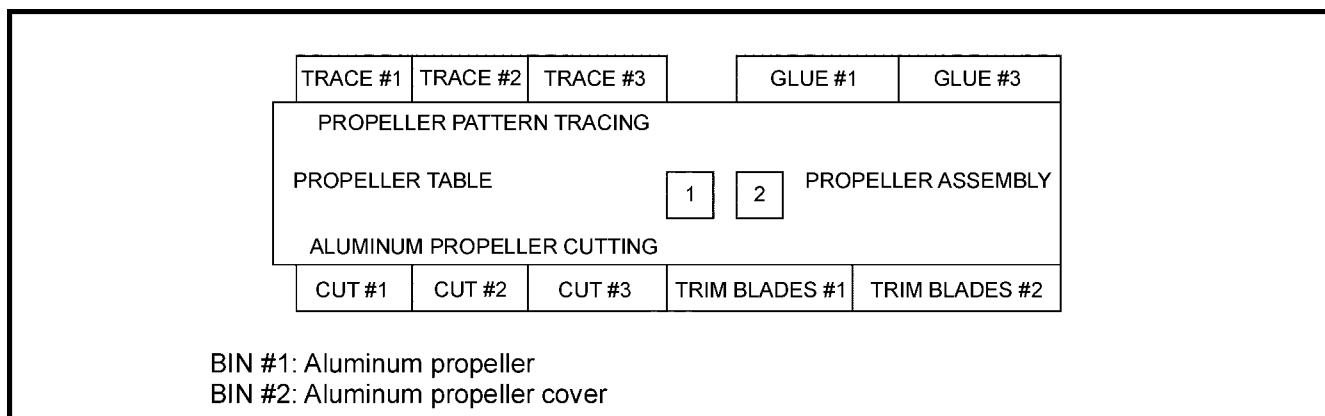

Director Cadets 3, 2007, Ottawa, ON: Department of National Defence

Figure 17AF-1 Propeller Assembly Line

For each aluminum model biplane to be constructed:

1. Place fan propeller template over part P-2 (from stock) and mark propeller blades of part P-2.
2. Cut propeller blades into part P-2.
3. Bend propeller blades out from part P-2 (Figure 17AF-3).
4. Trim propeller blade tip corner edges (completed propeller to stock).

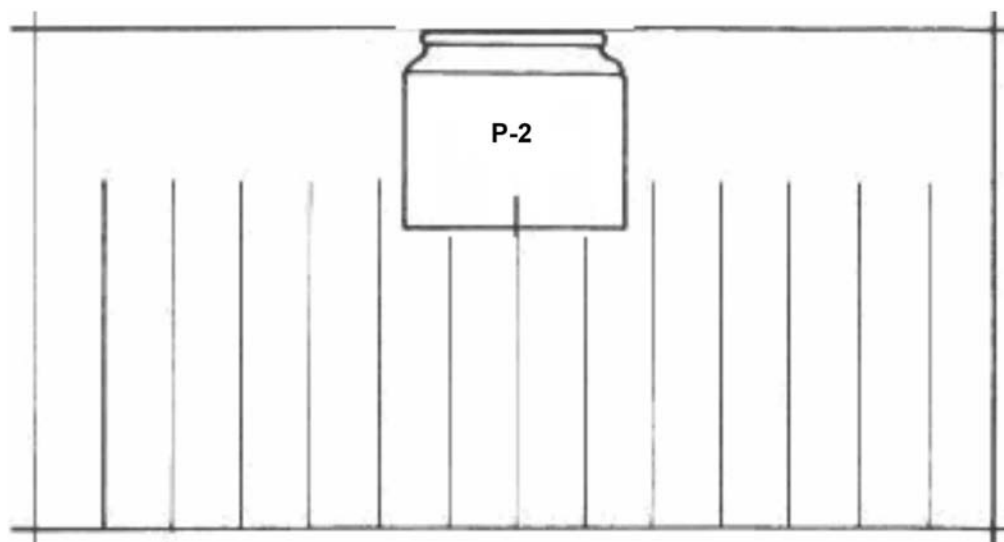

D. P. Mathis, Building the B.C. Air Originals Biplane, B.C. Air Originals (p. 21)

Figure 17AF-2 Marking the Propeller

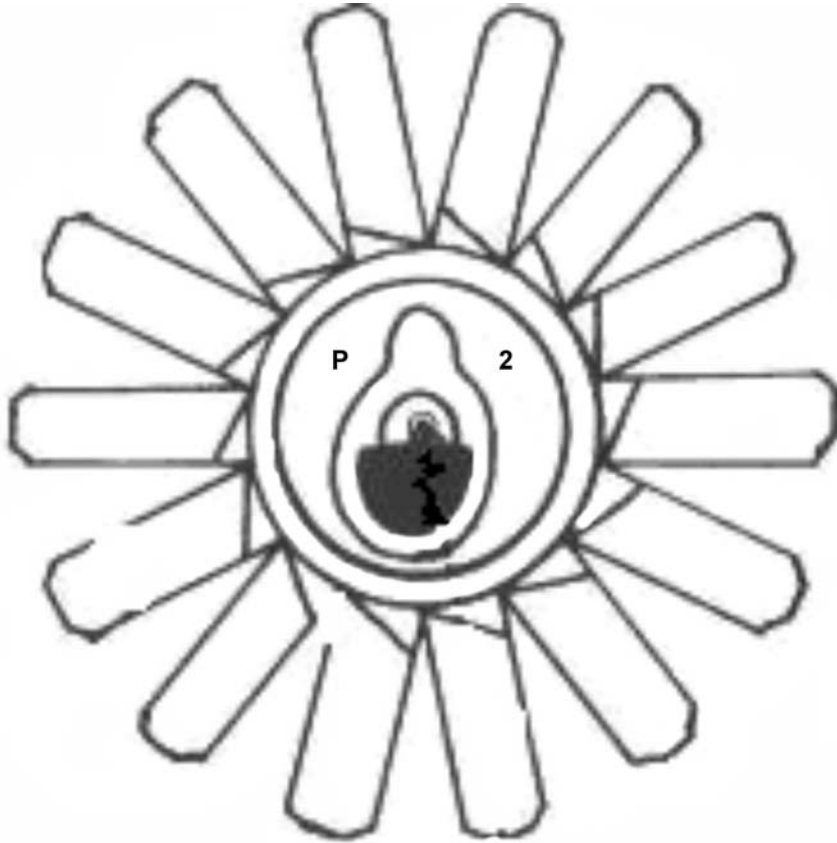

D. P. Mathis, Building the B.C. Air Originals Biplane, B.C. Air Originals (p. 21)
Figure 17AF-3 Fan Propeller

FINAL ASSEMBLY

Each cadet will receive a full set of aluminum model biplane assemblies and parts, to include:

- one completed empennage assembly,
 - one completed fan propeller assembly,
 - one completed top wing assembly,
 - one completed fuselage with bottom wing assembly,
 - one landing gear wire,
 - four 3-1/2-inch 10/24 bolts c/w 12 nuts to act as interplane struts,
 - four 2-1/2-inch 10/24 bolts c/w eight nuts to act as cabane or centre-section struts,
 - one metre of heavy-duty black thread to act as flying and landing wires,
 - a length of 3/32-inch wire 18 inches long to act as the propeller shaft, and
 - a length of 1/16-inch wire 6-3/4 inches long for a landing gear support wire.
1. Place four 3-1/2-inch 10/24 bolts through the outer holes in the top wing and secure snugly with a nut under the top wing and place another nut near the bottom of the bolts.

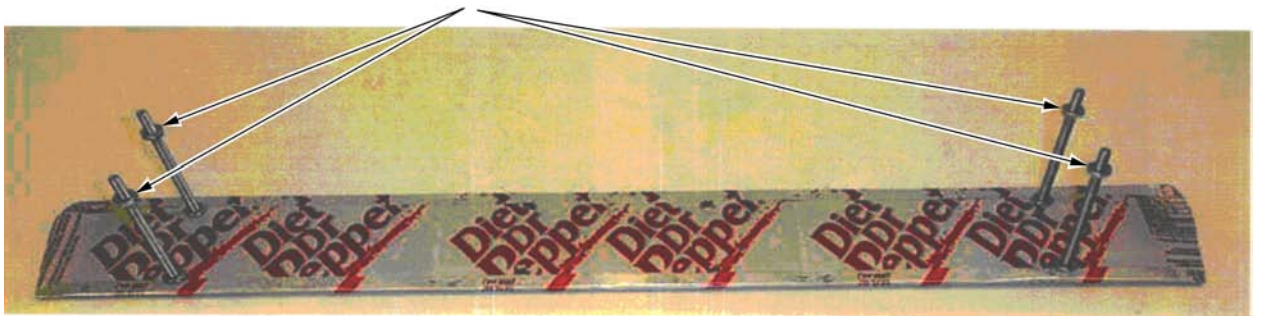

D. P. Mathis, Building the B.C. Air Originals Biplane, B.C. Air Originals (p. 12)

Figure 17AG-1 Interplane Struts

2. Secure the top wing to the bottom wing by pushing the four outer wing bolts through the bottom wing outer holes and threading the nuts down the bolts until they touch the upper surface of the bottom wing.



SECURE THE TOP WING TO THE BOTTOM WING BY PUSHING THE FOUR OUTER WING BOLTS THROUGH THE LOWER WING'S OUTER BOLT HOLES AND ADD ANOTHER NUT UNDER THE BOTTOM WING

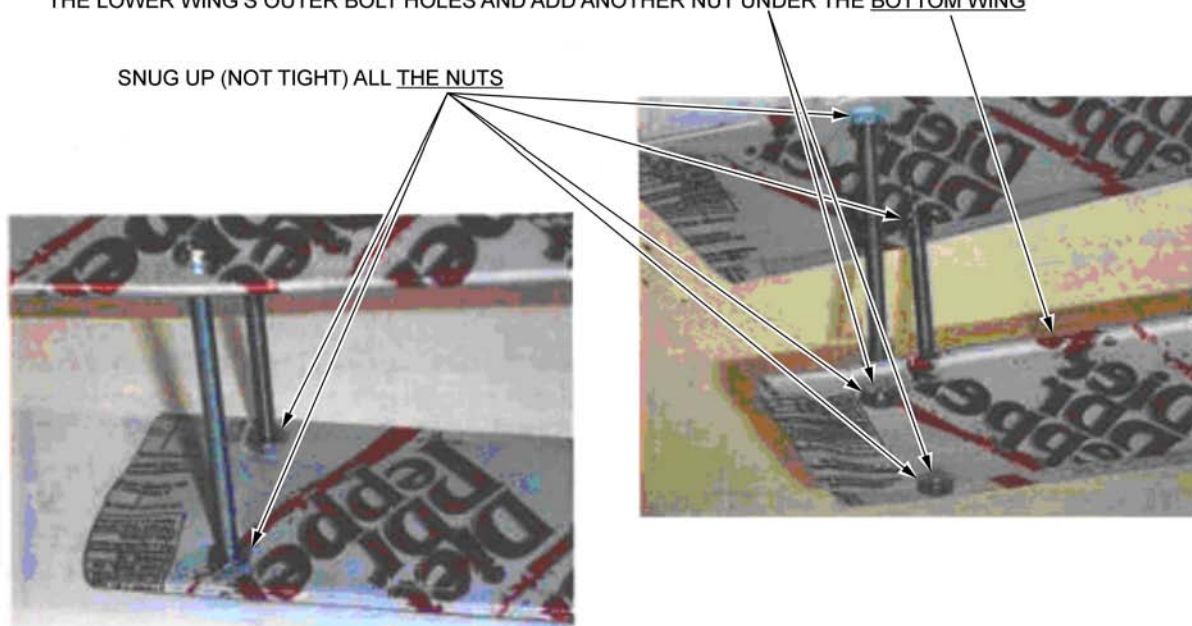

D. P. Mathis, Building the B.C. Air Originals Biplane, B.C. Air Originals (p. 13)

Figure 17AG-2 Top Wing

3. Secure the top wing to the fuselage by inserting four 2-1/2-inch 10/24 bolts through the top wing and threading two nuts on the ends of the bolts; then thread the bolt ends into the two front holes E and the two back holes F in the fuselage, making the nuts snug against the underside of the top wing and also the fuselage.

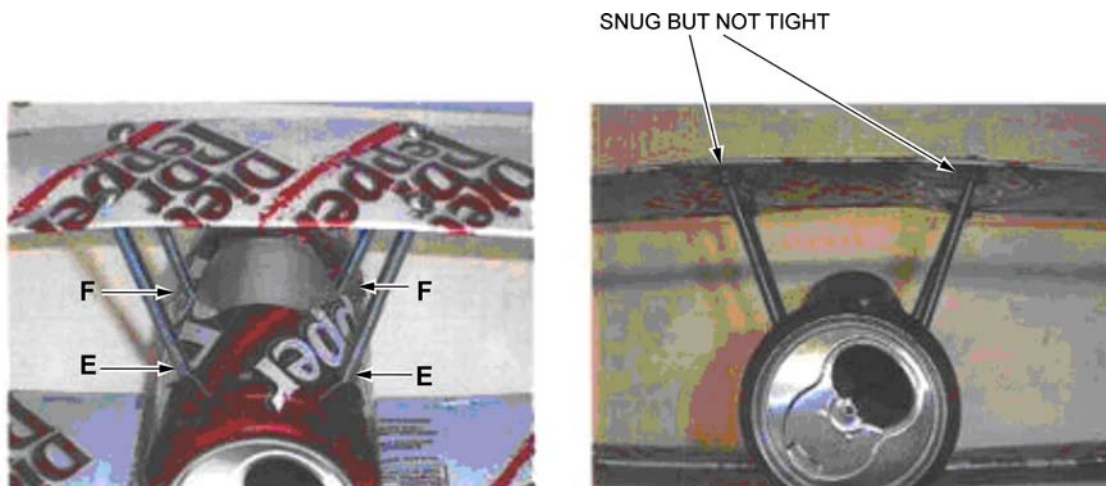

D. P. Mathis, Building the B.C. Air Originals Biplane, B.C. Air Originals (p. 13)

Figure 17AG-3 Cabane Struts

4. Install the landing wires.



D. P. Mathis, Building the B.C. Air Originals Biplane, B.C. Air Originals (p. 14)

Figure 17AG-4 Landing Wires

- a. To rig the plane, start by loosening the nut under the top wing outer front bolt (position 1 above).
- b. Wrap the line twice, between the nut and the aluminum, then tighten the nut.
- c. Now draw the line down to where the front wing spar goes into hole A in B-1 (position 2 above).
- d. Thread the line around the front wing spar, then draw it to the back wing spar (position 3 above).
- e. Thread the line around the back wing spar where it goes into hole B in B-1, then draw it up to the nut under the top wing outer back (position 4 above).
- f. Loosen this nut, wrap the line twice around the bolt between the nut and the aluminum, then tighten the nut.
- g. Repeat this on the other wing of the biplane.

5. Install the flying wires.

- a. Loosen the outer front nut on the top of the bottom wing (position 5 below) and wrap the line twice around the bolt, between the nut and the aluminum, and then tighten the nut.



D. P. Mathis, Building the B.C. Air Originals Biplane, B.C. Air Originals (p. 14)

Figure 17AG-5 Flying Wires

- b. Draw the line up to the inner front nut on the top wing (position 6 above).
- c. Loosen the nut, wrap the line twice around the bolt, between the nut and the aluminum, and tighten the nut.
- d. Repeat this on the other wing of the biplane.
- e. Loosen the outer back nut on the top of the bottom wing (position 7 above) and wrap the line twice around the bolt, between the nut and the aluminum, then tighten the nut.
- f. Draw the line up to the inner back nut on the top wing (8). Loosen the nut and wrap the line twice around the bolt and tighten the nut.
- g. Cut off all excess line.
- h. Repeat this on the other wing of the biplane.
6. Insert the landing gear wire through holes C and have the instructor make the final bend.

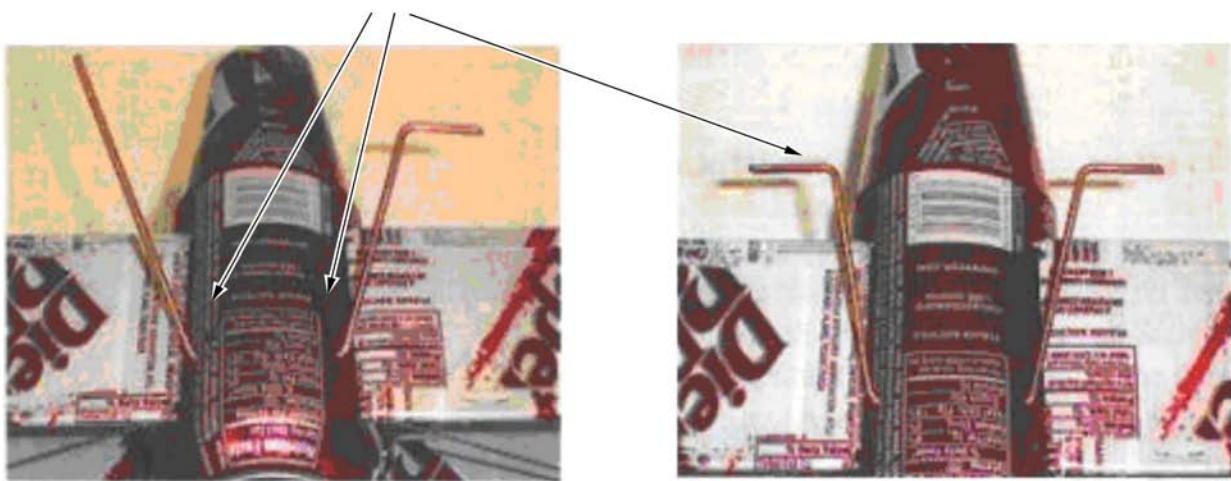

D. P. Mathis, Building the B.C. Air Originals Biplane, B.C. Air Originals (p. 15)

Figure 17AG-6 Main Landing Gear

7. Bend the 1/16-inch wire that is 6-3/4 inches long into shape as a support wire.

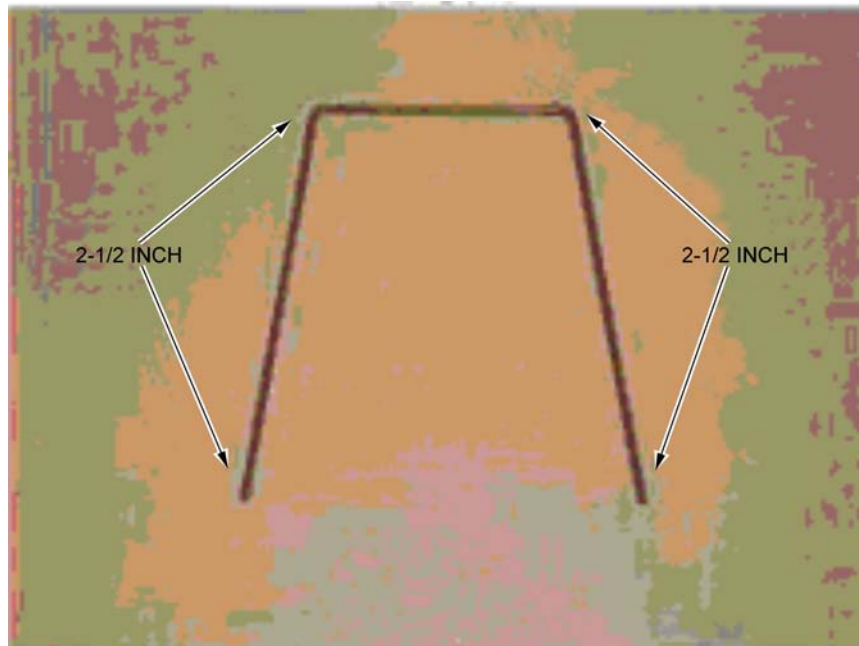

D. P. Mathis, Building the B.C. Air Originals Biplane, B.C. Air Originals (p. 15)

Figure 17AG-7 Main Landing Gear Support Structure

8. Insert the support wire through holes D in the fuselage and crimp it around the main landing gear wire.

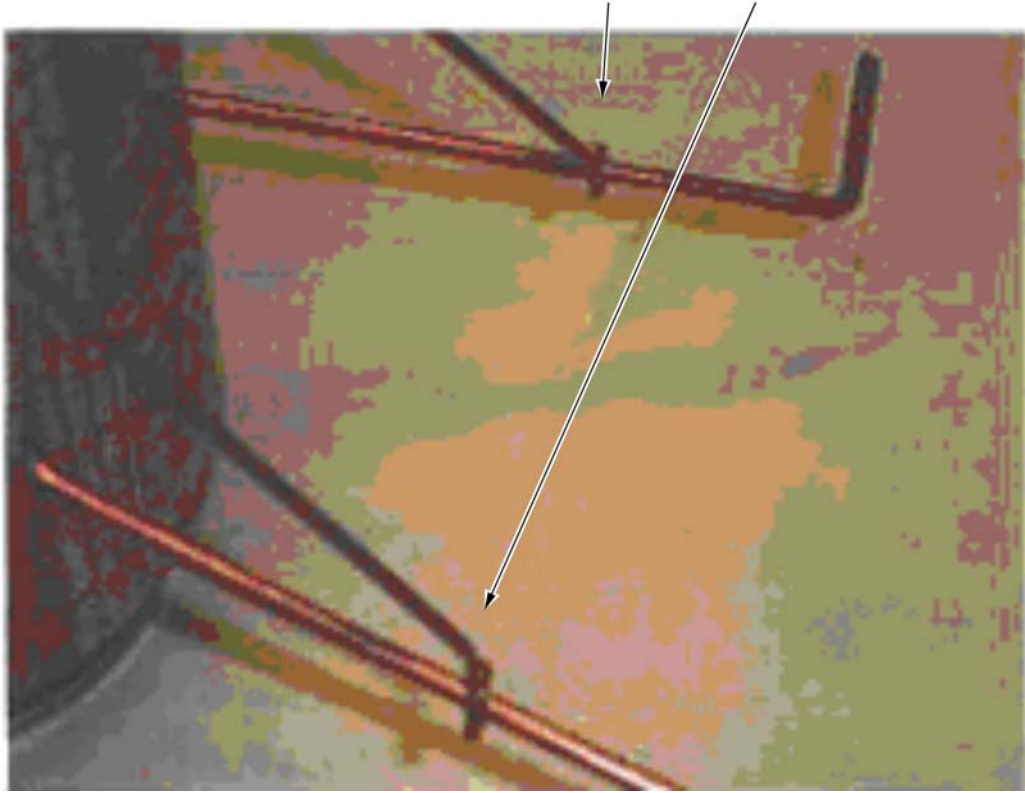

D. P. Mathis, Building the B.C. Air Originals Biplane, B.C. Air Originals (p. 15)

Figure 17AG-8 Crimping the Landing Gear Support

9. To attach the empennage to the fuselage, take a piece of 3/32-inch wire 18 inches long and make a 4-inch hook on one end to make the propeller shaft:
 - a. insert the propeller shaft through the hole in the back of the empennage under the horizontal stabilizer cardboard and the smaller section of wire goes over the horizontal stabilizer cardboard; and

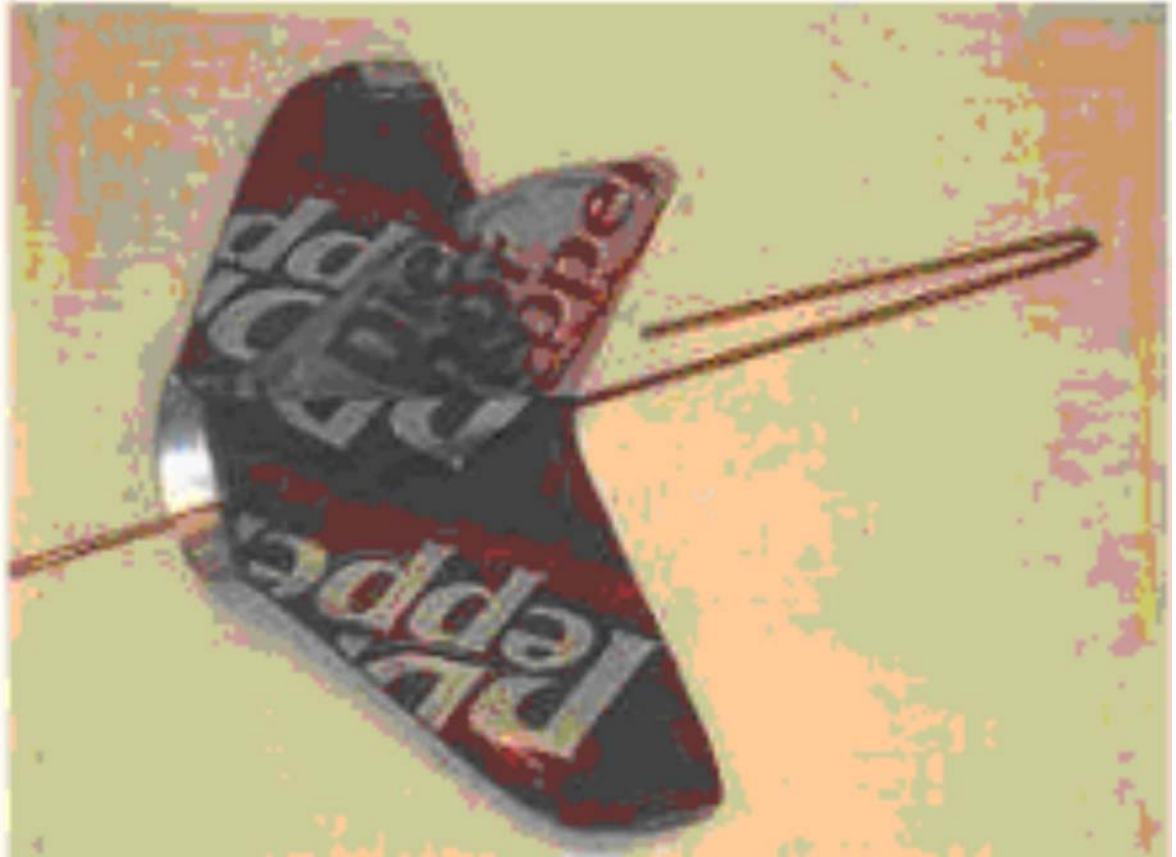

D. P. Mathis, Building the B.C. Air Originals Biplane, B.C. Air Originals (p. 16)

Figure 17AG-9 Propeller Shaft Installation

- b. insert the propeller shaft, with the empennage attached, through the pilot hole in the wood piece F-2, through the pilot hole in wood piece F-1 and through hole G in the front fuselage section part B-1. Pull the empennage over the rear of part B-2 at the rear of the fuselage. Pull the propeller shaft snug and hold it in place with a wire clip at the front of the fuselage part B-1.

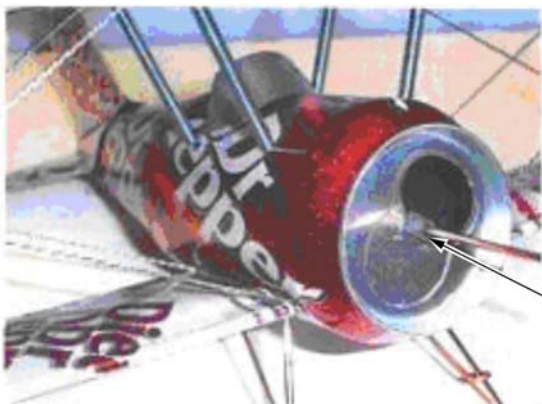

TAKE THE PROPELLER SHAFT, WITH THE TAIL SECTION ATTACHED, AND SLIDE IT THROUGH THE PILOT HOLE IN F-2, IN BACK END OF B-2, THROUGH THE PILOT HOLE IN F-1, IN B-2, AND THROUGH HOLE "G" IN THE FRONT OF B-1. PULL THE TAIL SECTION "OVER" THE BACK OF B-2. PULL THE PROPELLER SHAFT SNUG AND HOLD IT IN PLACE WITH A WIRE CLIP.

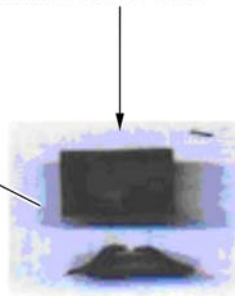

D. P. Mathis, Building the B.C. Air Originals Biplane, B.C. Air Originals (p. 17)

Figure 17AG-10 Propeller Shaft Wire Clip Installation

10. To fabricate the rear skid, take a piece of 3/32-inch wire and form it into the shape shown. Drill a hole through the fuselage into the bottom of wood piece F-2. Insert and glue the tail skid into place.



TAKE A PIECE OF LANDING GEAR WIRE APPROXIMATELY 2 INCHES LONG AND BEND IT INTO THE ABOVE SHAPE. DRILL A HOLE THROUGH THE BOTTOM OF THE TAIL SECTION, AND INTO F-2. INSERT AND GLUE THE TAIL WHEEL (SKID) IN PLACE.

D. P. Mathis, Building the B.C. Air Originals Biplane, B.C. Air Originals (p. 17)

Figure 17AG-11 Tail Skid Fabrication

11. Insert two windshield tabs into their slits as shown. Glue the windshield and the cockpit rubber into place.



D. P. Mathis, Building the B.C. Air Originals Biplane, B.C. Air Originals (p. 17)

Figure 17AG-12 Windscreen Installation

12. Using four bottle caps with holes through the centre, glue pairs together to make wheels as shown. Place and glue the two wheels on the main landing gear wires.

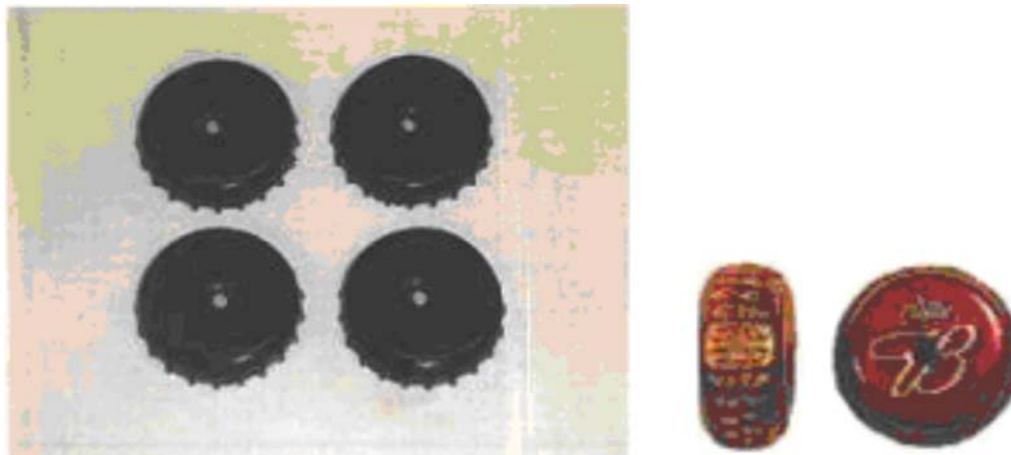

D. P. Mathis, Building the B.C. Air Originals Biplane, B.C. Air Originals (p. 18)

Figure 17AG-13 Bottle-Cap Wheels

13. Fill the hole at the rear of the empennage with glue.

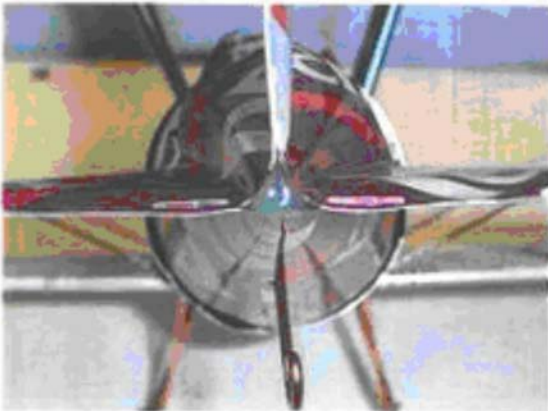

USE A HOT GLUE GUN TO FILL THE HOLE IN BACK OF THE TAIL SECTION WITH HOT GLUE

D. P. Mathis, Building the B.C. Air Originals Biplane, B.C. Air Originals (p. 17)

Figure 17AG-14 Tail Light

14. Attach the propeller part P-2 to the front of the fuselage by slipping it over the propeller shaft. Place the propeller cover part P-1 over the face of P-2 and glue it into place inside of P-2.

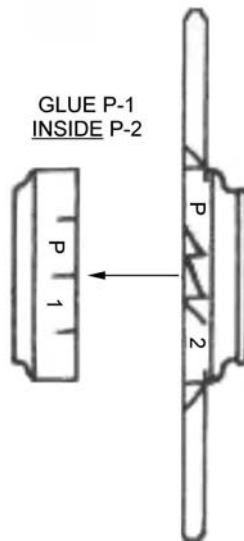

D. P. Mathis, Building the B.C. Air Originals Biplane, B.C. Air Originals (p. 21)

Figure 17AG-15 Finishing Touch



B.C. Air Originals "FAQ" Biplane. Retrieved November 19, 2007, from <http://www.bcair.com/faq/index.htm>

Figure 17AG-16 Aluminum Model Biplane

THIS PAGE INTENTIONALLY LEFT BLANK