

CHAPTER 12

PO 232 – IDENTIFY CHARACTERISTICS OF PISTON-POWERED AIRCRAFT



ROYAL CANADIAN AIR CADETS
PROFICIENCY LEVEL TWO
INSTRUCTIONAL GUIDE



SECTION 1

EO M232.01 – IDENTIFY TYPES OF AIRCRAFT ENGINES

Total Time: 30 min

PREPARATION

PRE-LESSON INSTRUCTIONS

Resources needed for the delivery of this lesson are listed in the lesson specification located in A-CR-CCP-802/PG-001, Chapter 4. Specific uses for said resources are identified throughout the Instructional Guide within the TP for which they are required.

Review the lesson content and become familiar with the material prior to delivering the lesson.

Create slides or handouts of [Annexes A](#) and [B](#).

PRE-LESSON ASSIGNMENT

N/A.

APPROACH

An interactive lecture was chosen for this lesson to introduce types of aircraft engines and give an overview of them.

INTRODUCTION

REVIEW

N/A.

OBJECTIVES

By the end of this lesson the cadet shall be expected to identify types of aircraft engines.

IMPORTANCE

Engines are one of the key systems in a powered aircraft. It is important for cadets to learn about types of aircraft engines so that they can understand subsequent and related aspects of aviation.

Teaching Point 1

Explain That a Powered Aircraft Needs a Means of Propulsion

Time: 10 min

Method: Interactive Lecture

A powered aircraft needs a means of propulsion to overcome drag and allow the wings to generate sufficient lift to overcome weight.

The propeller and jet engine are very closely related, providing thrust by the same means – the acceleration of a mass of air. The propeller generates thrust by acting on a large mass of air, giving it a relatively small acceleration. The jet engine does exactly the same thing by giving a larger acceleration to a smaller mass of air.

The most common engine types used for aviation propulsion employ internal combustion and they include:

- rocket engines,
- gas turbine jet engines, and
- reciprocating piston-powered engines.



Show the cadets a slide or handout of rocket engine applications in [Figures 12A-1](#) and [12A-2](#).

The earliest vehicle engines were rocket engines used to power ancient Chinese fire arrows. This method of propulsion proved so effective that, with many improvements, it is still commonly used today for many applications including space exploration. Self-contained with their own oxidizer, rockets have the great advantage of being able to function in a vacuum such as outer space.



All propulsion systems are reactive, meaning that they all employ an equal and opposite reaction predicted by Newton's third law of motion.

Piston-powered internal combustion engines were developed in the late nineteenth century. They were available to Orville and Wilbur Wright, who designed their 1903 flyer with a four-cylinder piston-powered engine.



Show the cadets a slide or handout of a Harvard piston-powered engine application in [Figures 12A-3](#) and [12A-4](#).

Piston-powered engines are the most common vehicle engine of all and the one that Proficiency Level Two cadets will explore in most detail. In many ways, pistons are the most complicated system of converting the chemical energy of fuel into the energy of motion but they are found in many places, including aircraft, automobiles, boats and lawnmowers.



Show the cadets a slide or handout of a gas turbine jet engine application in [Figures 12A-5](#) and [12A-6](#). Point out the airflow path and combustion location in the schematic.

Gas turbine jet engines are improvements upon simple ramjets. The ramjet is a liquid-fuelled rocket-like engine, which uses atmospheric oxygen to burn fuel. One of the most limiting aspects of a ramjet is that it requires high velocity to work. Therefore it cannot start combustion until it is up to speed – it must be launched from a speeding vehicle. Air-launched missiles are one of the few applications of ramjet engines.

Any turbine converts the energy of moving liquid or gases, such as jet exhaust or wind, into rotary motion to turn a shaft. A windmill is a turbine which uses wind energy to turn a shaft. Among other advantages, adding

a turbine to the simple ramjet allows a compressor to generate high-pressure air so that the gas turbine jet engine can be started from a resting, or static, position. This is the secret of the modern gas turbine jet engine, which still relies on the ejection of hot gases to produce thrust. Until the turbine and compressor are functioning and delivering high-pressure air to the engine, however, the engine cannot start. Even gas turbine jet engines, therefore, must be started with a starting motor.



Show the cadets a slide or handout of the CT-114 Tutor turbojet engine application [Figures 12A-7](#) and [12A-8](#).

A gas turbine jet engine that provides thrust, with no rotating shaft output, is a TURBOJET engine.



Show the cadets a slide or handouts of the C-130 Hercules turboprop engine application [Figures 12A-9](#) and [12A-10](#).

A gas turbine jet engine that provides thrust and also drives a propeller is a TURBOPROP engine.



Show the cadets a slide or handout of the CH-146 Griffon turboshaft engine application [Figures 12A-11](#) and [12A-12](#).

A gas turbine engine that drives a helicopter rotor is usually a TURBOSHAFT engine. In a turboshaft helicopter engine, the output driveshaft is separate from the compressor turbine shaft so that engine speed is not tied to the helicopter's main rotor speed.



Show the cadets a slide or handout of the CC-150 Polaris (A310-300 Airbus) turbofan engine application [Figures 12A-5](#) and [12A-6](#). Point out the fan location.

The most common variation of the gas turbine jet engine is the TURBOFAN, which is a hybrid of a turbojet and a turboprop. The turbofan has a fan that provides thrust with bypass air, in place of a propeller, adding to the reactive thrust of the ejected exhaust gases. This application allows the aircraft to go faster than normal propellers could go, while also reducing engine noise and allowing the aircraft to make efficient use of fuel. The noise reduction and fuel efficiency of turbofans make them very effective for commercial aviation.



All three of these engine types, rocket, gas turbine jet and piston-powered engines, use internal combustion to capture the energy of expanding hot gases in a closed container.

CONFIRMATION OF TEACHING POINT 1

QUESTIONS

Q1. Which engine type was the first to be used for propulsion?

- Q2. Why are the rocket, gas-turbine and piston-powered engines all internal combustion engines?
- Q3. Why does a gas turbine jet engine need to have a starting motor?

ANTICIPATED ANSWERS

- A1. The rocket was the first to be used for propulsion.
- A2. The rocket, gas-turbine and piston-powered engines all use internal combustion to capture the energy of hot expanding gases in a closed container.
- A3. A gas turbine jet engine needs to have a starting motor because, until the turbine and compressor are running, there is no high-pressure air to operate the engine.

Teaching Point 2

Explain Combustion in Rocket, Gas Turbine and Piston-powered Engines

Time: 5 min

Method: Interactive Lecture

All rocket, jet and piston-powered engines are internal-combustion engines because they all use burning fuel to generate power from expanding gases in a closed container. However, all these engine systems have important differences that distinguish them from one another.



Show the cadets a slide or handouts of combustion in [Figure 12B-1](#).

When fuel is oxidized it gives off heat. The heat causes expansion of the gases that result from the oxidization. If oxidization is very slow it is usually referred to simply as oxidization, or rusting. If the oxidization is faster, it is often referred to as burning. If it is very rapid, it is referred to as an explosion. All these processes result from fuel chemically combining with oxygen. The distinguishing characteristic between them is the speed of molecular combination.



Show the cadets a slide or handout of combustion locations in [Figures 12B-2](#) and [12B-3](#).

By capturing the expanding hot gases of combustion in a tightly closed container, such as a piston-powered engine's combustion chamber or a gas-turbine jet engine's combustor, the energy of the hot gases can be put to useful work. All the engine types discussed here contain the energy of expanding gases in a tight closed container, so all are said to be internal-combustion engines.

There have been many methods developed that direct and transmit this power. The most common is the turning of a shaft, such as a turbine shaft or a crankshaft. That shaft can then be used to turn an aircraft's propeller, the impeller of an air compressor, or an automobile's wheels.



A rocket applies the energy of the combustion's expanding gases in the most direct manner, by simply ejecting them to get the equal and opposite reaction. Gas-turbine and piston-powered engines apply the energy indirectly through moving machinery.

CONFIRMATION OF TEACHING POINT 2

QUESTIONS

- Q1. What causes burning gases to expand?
- Q2. What is the difference between fuel burning and fuel exploding?
- Q3. Which engine type applies the energy of expanding gases in the most direct manner?

ANTICIPATED ANSWERS

- A1. The heat of combustion causes the gases to expand.
- A2. The difference between burning and exploding is the speed of oxidization.
- A3. The rocket applies the energy of expanding gases in the most direct manner.

Teaching Point 3

Explain the Oxidization Process for Different Types of Engines

Time: 5 min

Method: Interactive Lecture

The simplest system of combining fuel with oxygen is the self-contained system of the rocket and the most intricate is the internal combustion engine, with gas turbine jets between those extremes.

The rocket carries its own fuel and oxygen and combines them in a closed container at a rate that will generate the energy needed at any given moment. Of course, the rocket will have to start out with enough oxygen to finish the mission, since it cannot get more from outside its closed container. So, the fuel and the oxygen must be carefully calculated and loaded before launch. The hot expanding gases that result from an explosion in the rocket's combustor are blasted out the back of the rocket at high speed through a nozzle. The nozzle applies the equal and opposite reaction of the moving gases to the body of the rocket, propelling it upward.



A jet engine is similar to a rocket engine but, because a jet engine uses air for oxidization, it must allow for the fact that air is mostly nitrogen and only about 20 percent oxygen. Therefore, obtaining enough oxygen for efficient combustion in a jet engine requires that air be somehow compressed before combustion takes place.

A gas turbine jet engine typically resembles a hollow cylinder with air sucked in the front and blasted out the back. These can be seen slung under the wing of most airliners. The fuel to be burned is stored in tanks, often in the aircraft's wing. The air, which is sucked by a compressor fan into the front of the engine, contains the oxygen that is needed for oxidization of the fuel. The fuel is combined or mixed with the pressurized air and the mixture is detonated in a container within the engine called a combustor. As in a rocket, the hot expanding gases are blasted out the back of the engine through a nozzle that applies the equal and opposite reaction of the moving gases to the body of the engine, propelling it forward. Significant in this is the presence of a turbine beside the combustor, which uses a portion of the hot expanding gases to spin a shaft. That shaft drives the compressor fan to suck the air into the engine. This system of generating propulsion power has proven so useful and reliable that many variations of the basic theme have been developed and given names such as "fan-jet", "turboprop" and "turboshaft".



Specialized gas-turbine applications are explored in complementary lessons of Proficiency Level Two.

The most intricate method of generating power by oxidizing fuel is the most common. The reciprocating piston-powered engine is encountered in many applications. In a four-stroke piston-powered engine, air is carefully mixed with atomized fuel droplets and then either sucked or injected into cylinders where the mixture is detonated to drive pistons in a cycle of intake, compression, power, and exhaust. These cycles will be examined in EO M232.03 (Participate in a Discussion on the Cycles of a Four-Stroke Piston-Powered Engine).

CONFIRMATION OF TEACHING POINT 3

QUESTIONS

- Q1. Where does a rocket get oxygen to burn fuel in outer space?
- Q2. What is used to spin the turbine in a gas-turbine engine?
- Q3. Where does a jet engine, such as a gas-turbine, get oxygen to burn fuel?

ANTICIPATED ANSWERS

- A1. A rocket carries its own oxygen in addition to its fuel.
- A2. A portion of the hot expanding gases from the engine's combustor is used to spin the turbine.
- A3. Air entering the front of the engine contains oxygen that is used for oxidization of fuel.

Teaching Point 4

Identify Aircraft and Associated Engine Types

Time: 5 min

Method: Interactive Lecture



Show the cadets slides or handouts, located at [Annex A](#), of the following aircraft pictures and, in each case, ask the cadets to identify the aircraft. Then, tell the cadets the aircraft's engine type and ask the cadets to consider the following points:

Figure 12A-9 [C-130 Hercules](#): four Allison T-56-A-7/15 turboprop engines.

Engine type is selected for the anticipated mission, so why does the C-130 Hercules in [Figure 12A-9](#) have turboprops?

Today, the distinction between tactical airlift and strategic airlift depends not so much on the number of a transport aircraft's engines as on their type: jet-engine aircraft are generally seen as "strategic", while turboprop-powered (and therefore slower and shorter-ranged) aircraft are "tactical". Tactical transports are also usually designed to operate on rougher, shorter, more primitive airfields than the facilities required by strategic transports.

Figure 12A-5 [CC-150 Polaris](#): two General Electric CF6-80C2A2 turbofan engines.

What is the main purpose of the CC-150 Polaris?

This strategic lift aircraft's primary role is long-range transport of personnel and equipment, up to 194 passengers or 32 000 kg of cargo. They have participated in operations supporting the CF, NATO and numerous UN and Red Cross initiatives.

Figure 12A-3 Harvard North American T-6J: one nine-cylinder Pratt & Whitney radial engine.

What is happening in [Figure 12A-3](#)?

Harvard number 20449 was a North American T-6J, one of the last of 270 such aircraft taken on strength by the RCAF in November, 1951. It was assigned to No. 1 Flying Instructors School which had been reformed at RCAF Station Trenton, Ontario on April 1, 1951. It then followed the school as it moved to RCAF Station Moose Jaw on June 8, 1959 where the school still exists today as Canadian Forces Flying Instructors School. The training aircraft was then upgraded from the Harvard to the Canadair CT-114 Tutor. The aerobatic display team of the 1950s was the Golden Hawks. The flying instructors so disparaged their former students' efforts that they formed their own team, the Goldilocks, with the Harvard training aircraft, showing what they thought of their students' formation-flying abilities.

Figure 12A-7 CT-114 Tutor: one General Electric J85-CAN-40 turbo jet engine.

[Figure 12A-7](#) looks familiar. Where have we seen that aircraft before?

When the Snowbirds, Canada's world famous aerial acrobatic team, perform high above the clouds, their Canadair CT-114 Tutors are put through their paces. The Tutor, a Canadian designed and produced single-engine subsonic jet trainer that entered service in the mid-1960s, was used for basic and advanced pilot training until it was replaced by the CT-156 Harvard II and CT-155 Hawk in 2000.

Figure 12A-11 CH-146 Griffon: one Pratt & Whitney PT6T-3D turboshaft engine.

What is a Griffon used for?

As Canada's Utility Transport Tactical Helicopter (UTTH), the Griffon provides a robust, reliable and cost-effective capability to conduct: airlift of equipment and personnel, command and liaison flights, surveillance and reconnaissance, casualty evacuation, logistic transport, search and rescue, counter-drug operations, and domestic relief operations.

CONFIRMATION OF TEACHING POINT 4

The cadets' participation in the aircraft identification will serve as the confirmation of this TP.

END OF LESSON CONFIRMATION

QUESTIONS

- Q1. Why are the rocket, gas-turbine and piston-powered engines all internal combustion engines?
- Q2. What is used to spin the turbine in a gas-turbine engine?
- Q3. What causes burning gases to expand?

ANTICIPATED ANSWERS

- A1. The rocket, gas-turbine and piston-powered engines all use internal combustion to capture the energy of hot expanding gases in a closed container.
- A2. A portion of the hot expanding gases from the engine's combustor is used to spin the turbine.
- A3. The heat of combustion causes the gases to expand.

CONCLUSION

HOMEWORK/READING/PRACTICE

N/A.

METHOD OF EVALUATION

N/A.

CLOSING STATEMENT

The topic of aircraft engines is very broad and ever-changing as new solutions are found and new products developed to push the performance envelope.

INSTRUCTOR NOTES/REMARKS

If a computer and projector are available, software to demonstrate engine operation can be found at the Websites listed below.

REFERENCES

- A3-031 Canadian Forces. *Aircraft*. (2006). Retrieved 20 November 2006, from http://www.airforce.gc.ca/equip/equip1_e.asp.
- C3-084 NASA Glenn Research Center. *Engines 101*. Retrieved 21 February 2007, from <http://www.ueet.nasa.gov/Engines101.html#Aeronautics>.
- C3-086 NASA Glenn Research Center. *Engines 101*. Retrieved 21 February 2007, from <http://www.grc.nasa.gov/WWW/K-12/airplane/icengine.html>.
- C3-087 NASA Glenn Research Center. *Propulsion Index*. Retrieved 21 February 2007, from <http://www.grc.nasa.gov/WWW/K-12/airplane/shortp.html>.
- C3-088 NASA. *Welcome to the Beginner's Guide to Rockets*. Retrieved 21 February 2007, from <http://exploration.grc.nasa.gov/education/rocket/bgmr.html>.
- C3-116 A-CR-CCP-263/PT-001/(ISBN 0-9680390-5-7) MacDonald, A. F. and Pepler, I. L. (2000). *From the Ground Up: Millennium Edition*. Ottawa, ON: Aviation Publishers Co. Limited.
- C3-120 Pratt & Whitney Canada. (2006). *Imagine the Power*. Retrieved 18 March 2007, from http://www.pwc.ca/en/3_0/3_0_3/3_0_3_3_1.asp.
- C3-121 NASA. (2007). *Missions: Space Shuttle Main Engines*. Retrieved 18 March 2007, from http://www.nasa.gov/returntoflight/system/system_SSME.html.



ROYAL CANADIAN AIR CADETS

PROFICIENCY LEVEL TWO

INSTRUCTIONAL GUIDE



SECTION 2

EO M232.02 – IDENTIFY THE COMPONENTS OF PISTON-POWERED INTERNAL COMBUSTION ENGINES

Total Time: 60 min

PREPARATION

PRE-LESSON INSTRUCTIONS

Resources needed for the delivery of this lesson are listed in the lesson specification located in A-CR-CCP-802/PG-001, Chapter 4. Specific uses for said resources are identified throughout the Instructional Guide within the TP for which they are required.

Review the lesson content and become familiar with the material prior to delivering the lesson.

Create slides or handouts of [Figures 12C-1 to 12C-3](#), and [12D-1](#), [12E-1](#) and [12F-1](#) respectively.

Copy handouts of [Figure 12C-4](#) for each cadet.

PRE-LESSON ASSIGNMENT

N/A.

APPROACH

An interactive lecture was chosen for TP1 to TP3 to introduce the components of internal combustion engines and give an overview of them.

An in-class activity was chosen for TP4 as it is an interactive way to provoke thought and stimulate an interest among cadets.

INTRODUCTION

REVIEW

N/A.

OBJECTIVES

By the end of this lesson the cadet shall be expected to identify the components of piston-powered internal combustion engines.

IMPORTANCE

It is important for cadets to learn about the components of piston-powered internal combustion engines so that they can develop an understanding of subsequent and related principles of aviation.

Teaching Point 1**Identify and Explain the Operations of the Major Components of a Piston-powered Engine**

Time: 25 min

Method: Interactive Lecture

MAJOR COMPONENTS OF A PISTON-POWERED ENGINE

Show the cadets a slide or handout of the piston-powered engine in [Figure 12C-1](#).

Cylinder. In order to understand how an engine works, it is necessary to first know what parts make up an engine. The cylinder is the main component. This is where the combustion of a gasoline and air mixture takes place.

Piston. The piston is found in the cylinder and is driven up and down by the exploding air and fuel mixture.

Connecting Rod. The piston is attached by a connecting rod to the crankshaft. The connecting rod is joined to the piston and to the crankshaft with bearings which allow movement so that the reciprocating (up-and-down) motion of the piston can be transformed into rotary (spinning) motion of the crankshaft.

Crankshaft. As the piston drives up and down, the connecting rod rotates around the crankshaft, turning it. The crankshaft can rotate while the piston goes up and down.

Camshaft. The crankshaft often turns a second shaft called a camshaft. The cams are bumps on the camshaft that open and close the intake and exhaust valves at the correct time. Of course, the crankshaft also powers the aircraft's propeller. Each cylinder has at least one set of valves operated by the cams on the camshaft. The intake valve opens to let the mixture of gasoline and air into the cylinder and then it closes. Once this is done and the mixture is burnt, the exhaust valve opens to release the exhaust and then closes.

Distributor. The gasoline and air mixture is ignited by a spark plug. Most aircraft have two spark plugs in every cylinder. The fuel takes time to burn completely. Because of this time delay, the spark must happen at just the right time; a fraction of a second before the piston has reached the top of its stroke. In a multi-cylinder engine such as aircraft use, an electrical signal must be sent to each cylinder's spark plug at exactly the right time. The timing and distribution of spark sometimes relies on a central distributor, which is worked by gears from the crankshaft. Should this distributor fail, the engine will stop. A better, though more expensive method, is to equip each cylinder with its own spark timing and delivery system.



Show the cadets a slide or handout of a carburetor in [Figure 12C-2](#).

Carburetor. Before fuel is delivered to the cylinder for detonation, it is mixed with air in exact proportion. A fuel injector or a carburetor does this. For effective detonation and clean burning, the fuel must be broken into tiny droplets and mixed with air.

Oil Sump. The moving parts of the engine all need to be coated with engine oil. Oil is provided under pressure to make sure that all moving parts are coated. A wet sump stores the oil supply in the crankcase with the crankshaft, while a dry sump stores the oil in a separate tank and delivers it to the engine via piping.



Show the cadets a slide or handout of a dry-sump lubrication system in [Figure 12C-3](#).



The oil is circulated and re-used, serving other purposes in addition to lubrication. As the oil circulates, it cleans the engine by flushing dirt out of the engine. It also cools the engine by carrying heat away and it improves the pressure seal to keep the combustion chamber airtight.



Have the cadets label the parts of a piston-powered engine in [Figure 12C-4](#).

CONFIRMATION OF TEACHING POINT 1

QUESTIONS

- Q1. Where does combustion take place in a piston-powered engine?
- Q2. What two valves does a piston-powered engine have?
- Q3. Why does the piston go up and down?

ANTICIPATED ANSWERS

- A1. In a piston-powered engine, combustion takes place in the cylinder.
- A2. Piston-powered engines have an intake valve and an exhaust valve.
- A3. The detonation of the air and fuel mixture drives the pistons up and down.

Teaching Point 2

Explain the Difference Between Rotary Engines and Radial Engines

Time: 5 min

Method: Interactive Lecture

Some early aircraft engines used rotary engines in which the cylinders themselves rotated around the stationary central crankshaft. These were different than the later radial engines in which the stationary cylinders were arranged around the rotating crankshaft.

Many larger older aircraft had radial engines. In this design the cylinders were arranged in a circle at the front of the engine with the cylinder tops pointed outwards. The crankshaft ran through the middle of the cylinders to the front of the aircraft. Radial engines had many cylinders; some aircraft from World War II had 13 cylinders.

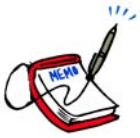

Show the cadets a slide or handout of the radial engine located at [Annex D](#).

Even older aircraft, before and during World War I, had rotary engines that were different but were often confused with the later radial types. In the rotary engine, the crankshaft was stationary and the cylinders rotated around the crankshaft. This is the opposite of the radial engine, which had stationary cylinders and rotating crankshaft. Rotary engine design was abandoned because the great weight of the spinning cylinders was found to interfere with turning the aircraft in flight.

CONFIRMATION OF TEACHING POINT 2

QUESTIONS

- Q1. In a rotary engine which part rotates and which part is stationary?
- Q2. Why was rotary engine design abandoned for aircraft?
- Q3. How were the stationary cylinders arranged in an aircraft's radial engine?

ANTICIPATED ANSWERS

- A1. In a rotary engine the cylinders rotate and the driveshaft is stationary.
- A2. Rotary engine design was abandoned for aircraft because the great weight of the rotating cylinders was found to interfere with turning the aircraft in flight.
- A3. In radial engines the cylinders were arranged in a circle at the front of the engine with the cylinder tops pointed outwards.

Teaching Point 3

Describe Aircraft Engine Arrangements

Time: 10 min

Method: Interactive Lecture

Internal combustion engines come in a variety of styles that are described by how the cylinders are configured.



Show the cadets a slide or handout of the horizontally opposed engine located at [Annex E](#).

The horizontally opposed engine is most commonly used in general aviation airplanes. This engine has two banks of cylinders lying flat, directly opposite each other and working on the same crankshaft. There may be four, six or eight cylinders. The advantage of this engine type is its flat shape that generates less form drag. Form drag is a force that opposes the aircraft's movement through the air.



Show the cadets a slide or handout of an in-line engine located at [Annex F](#).

Some older aircraft have in-line engines. This was the first type of aircraft engine used in great numbers. In an in-line engine, the cylinders are lined up in a row from the front of the engine to the back, with the tops pointed up. The crankshaft runs under the cylinders to the front of the aircraft.

CONFIRMATION OF TEACHING POINT 3

QUESTIONS

- Q1. How are the cylinders arranged in an in-line engine?
- Q2. How are the cylinders arranged in a horizontally opposed engine?
- Q3. Why are horizontally opposed engines the favoured design for small aircraft engines?

ANTICIPATED ANSWERS

- A1. In an in-line engine, the cylinders are lined up in a row from the front of the engine to the back.
- A2. A horizontally opposed engine has two banks of cylinders lying flat, directly opposite each other.
- A3. The horizontally opposed engine's flat shape generates less form drag.

Teaching Point 4

Play a Game of Piston-powered Baseball

Time: 15 min

Method: In-class Activity

ACTIVITY

OBJECTIVE

The objective of this activity is to have the cadets use the information learned in this lesson to play a game that reviews the topic.

RESOURCES

- List of questions and answers located at [Annex G](#),
- Coin,
- One large die,
- Coloured poster board, and
- Masking tape.

ACTIVITY LAYOUT

Re-arrange the classroom into the shape of a baseball diamond with poster board bases, using masking tape to connect the bases with baselines.

ACTIVITY INSTRUCTIONS

- For this review game, the instructor acts as, “pitcher”, “umpire” and “scorekeeper”.
- Two teams are chosen and each is seated in a “dugout” of chairs in opposing baselines in “batting order”. A coin is tossed to see which team is at bat first.
- The instructor “pitches” a question to the first batter. Teammates are encouraged to give hints to the batter, but the batter must choose the answer.
- If the answer is wrong, the batter is out.
- If the answer is correct, the die is thrown. If a one, two or three comes up, the player goes to first, second or third base, respectively. A four is a home run.
- A five on the die means a foul ball and the player must field another question. There are two ways to be out – either answering incorrectly or rolling a six.
- Players on base are “forced” ahead by the next runner and will score if forced to home base.
- After three outs, the other team gets to bat.
- After five runs are batted in, the next team is up at bat.
- The process is repeated as long as time permits.

SAFETY

N/A.

CONFIRMATION OF TEACHING POINT 4

The cadets’ participation in the activity will serve as the confirmation of this TP.

END OF LESSON CONFIRMATION

QUESTIONS

- Q1. Where does combustion take place in a piston-powered engine?
- Q2. How were the stationary cylinders arranged in an aircraft’s radial engine?
- Q3. Why are horizontally opposed engines the favoured design for small aircraft engines?

ANTICIPATED ANSWERS

- A1. In a piston-powered engine, combustion takes place in the cylinder.
- A2. In radial engines, the cylinders were arranged in a circle at the front of the engine with the cylinder tops pointed outwards.
- A3. The horizontally opposed engine’s flat shape generates less form drag.

CONCLUSION

HOMEWORK/READING/PRACTICE

N/A.

METHOD OF EVALUATION

N/A.

CLOSING STATEMENT

The generation and control of power is limited only by our imaginations and so, for over one 100 years, aircraft engines have been constantly improved with new designs.

INSTRUCTOR NOTES/REMARKS

If a computer and projector are available, software to demonstrate engine operation can be found at the Websites listed below.

REFERENCES

- C3-003 (ISBN 0-943210-44-5) Pike, B. and Busse, C. (1995). *101 More Games for Trainers*. Minneapolis, MN: Lakewood Books.
- C3-086 NASA Glenn Research Center. *Engines 101*. Retrieved 21 February 2007, from <http://www.grc.nasa.gov/WWW/K-12/airplane/icengine.html>.
- C3-087 NASA Glenn Research Center. *Propulsion Index*. Retrieved 21 February 2007, from <http://www.grc.nasa.gov/WWW/K-12/airplane/shortp.html>.
- C3-116 A-CR-CCP-263/PT-001/(ISBN 0-9680390-5-7) MacDonald, A. F. and Pepler, I. L. (2000). *From the Ground Up: Millennium Edition*. Ottawa, ON: Aviation Publishers Co. Limited.

THIS PAGE INTENTIONALLY LEFT BLANK



ROYAL CANADIAN AIR CADETS
PROFICIENCY LEVEL TWO
INSTRUCTIONAL GUIDE



SECTION 3

EO M232.03 – EXPLAIN THE CYCLES OF A FOUR-STROKE PISTON-POWERED ENGINE

Total Time: 60 min

PREPARATION

PRE-LESSON INSTRUCTIONS

Resources needed for the delivery of this lesson are listed in the lesson specification located in A-CR-CCP-802/PG-001, Chapter 4. Specific uses for said resources are identified throughout the Instructional Guide within the TP for which they are required.

Review the lesson content and become familiar with the material prior to delivering the lesson.

Create slides or photocopy handouts of [Figures 12H-1](#) to [12H-6](#) for each cadet.

Photocopy handouts of [Figure 12I-1](#) for each cadet.

PRE-LESSON ASSIGNMENT

N/A.

APPROACH

An interactive lecture was chosen for TP1 to TP4 to introduce the cycles of a four-stroke piston-powered engine and give an overview of them.

An in-class activity was chosen for TP5 as it is an interactive way to provoke thought and stimulate an interest among the cadets.

INTRODUCTION

REVIEW

N/A.

OBJECTIVES

By the end of this lesson the cadet shall be expected to explain the cycles of a four-stroke piston-powered engine.

IMPORTANCE

It is important for cadets to learn about the cycles of a four-stroke piston-powered engine so that they will understand the process by which an aircraft operates.

Teaching Point 1**Explain the Purposes of the Strokes of a Four-stroke Piston**

Time: 15 min

Method: Interactive Lecture

CYCLES OF A FOUR-STROKE PISTON-POWERED ENGINE

The parts of an engine work together in a cycle to turn the aircraft's propeller. In most aircraft engines, this cycle has four distinct stages called strokes:

- the intake stroke draws fuel and air into the cylinder;
- the compression stroke forces the fuel and air into the combustion chamber;
- the power stroke transmits the energy of the exploding fuel to the crankshaft; and
- the exhaust stroke cleans the cylinder of exhaust fumes and prepares it for the next intake stroke.



The piston travels four strokes (two up and two down) to complete one cycle. During this operation, the crankshaft goes through two complete revolutions.

The Intake (Induction) Stroke

Show the cadets a slide or distribute the handout of the intake stroke in [Figure 12H-1](#).

During the first (intake) stroke, the intake valve opens to let the gasoline and air mixture into the cylinder and the piston moves down to draw the mixture into the cylinder. The exhaust valve is closed during this stroke.

The Compression Stroke

Show the cadets a slide or distribute the handout of the compression stroke in [Figure 12H-2](#).

In the second (compression) stroke, both valves are closed while the piston moves up to compress the mixture.

The Power (Combustion) Stroke

Show the cadets a slide or distribute the handout of the power stroke in [Figure 12H-3](#).

In the third (power) stroke, both valves remain closed while the spark plug ignites the gas, which burns, expands and forces the piston down again.

The Exhaust Stroke



Show the cadets a slide or distribute the handout of the exhaust stroke in [Figure 12H-4](#).

In the fourth (exhaust) stroke, the exhaust valve is open to let the burnt gases out while the intake valve is closed. The piston moves up again to force the burned gases out through the open exhaust valve.



Show the cadets a slide or distribute the handout of the four strokes of a piston-powered engine in [Figure 12H-5](#).

After the exhaust stroke, the whole process repeats itself thousands of times per minute, causing the crankshaft to turn the propeller on the aircraft.

CONFIRMATION OF TEACHING POINT 1

QUESTIONS

- Q1. What must happen between the power stroke and the exhaust stroke?
- Q2. What must happen before the power stroke can take place?
- Q3. How many complete revolutions of the crankshaft are in four strokes?

ANTICIPATED ANSWERS

- A1. Between the power stroke and the exhaust stroke, the exhaust valve must open.
- A2. Fuel and air must be taken in, all valves must close and the spark plug must ignite.
- A3. The crankshaft goes through two complete revolutions in four strokes (two down and two up).

Teaching Point 2

Identify and Explain the Operation of Valves and Camshafts

Time: 5 min

Method: Interactive Lecture

Other important components of piston-powered four-stroke internal combustion engines are the cam systems, which operate the valves.



Show the cadets a slide or distribute the handout of the cam and valve mechanism in [Figure 12H-6](#).

Since the crankshaft rotates in time with the piston movements, its rotation is used to provide signals to the valves, telling them when to open. The usual method is to arrange for the crankshaft to turn a secondary shaft (camshaft) that has lobes, or cams, raised on its surface. The shape of the cam is such that it mechanically

pushes its associated valve open – there are many ways to mechanically arrange this – just the right amount at just the right time.



The crankshaft provides the timing information to the valves by using cams on a camshaft to push the valves open. The camshaft is usually connected to the crankshaft through gears.

CONFIRMATION OF TEACHING POINT 2

QUESTIONS

- Q1. From what engine component is the valve timing first taken?
- Q2. What pushes the valve open the right amount at the right time?
- Q3. How does the timing information usually get from the crankshaft to the cam?

ANTICIPATED ANSWERS

- A1. The valve timing is taken first from the crankshaft.
- A2. A cam on a rotating camshaft pushes the valve open the right amount at the right time.
- A3. The crankshaft provides the timing information to the valves by using cams on a camshaft to push the valves open. The camshaft is usually connected to the crankshaft through gears.

Teaching Point 3

Explain the Timing of Electrical Ignition Spark Distribution

Time: 10 min

Method: Interactive Lecture

Efficient, complete burning takes time. Even though an explosive detonation like that found in a piston-powered engine cylinder seems to happen in an instant, time is actually required. The engine turns very fast, thousands of revolutions per minute, so time is short. To ensure that the fuel is burned completely and that all energy is recovered from the fuel, the spark that sets off the detonation must be delivered while the piston is still rising on the compression stroke. If the spark arrives during the power stroke there is not enough time to burn the fuel completely and unburned fuel is exhausted. This would be an inefficient waste of fuel and it would contribute to environmental pollution in the form of blue smoke. Therefore, the timing of the spark plug's electrical signal must be exact.



Each spark plug of each cylinder must get its electrical signal as the piston is rising, before the end of the compression stroke.

The timing for spark distribution also originates from the crankshaft through a system of gears, which provide coarse, or rough, timing. The need for precision timing is so great that a technician usually measures spark timing with electronic tools to ensure precision during engine tune-ups.

CONFIRMATION OF TEACHING POINT 3

QUESTIONS

- Q1. Why is the spark delivered to the cylinder early, during the compression stroke?
- Q2. Where is the timing of the spark taken from?

Q3. How many revolutions per minute does a working engine complete?

ANTICIPATED ANSWERS

- A1. The spark is delivered early because complete burning of the fuel takes time.
- A2. Timing of the spark comes from the crankshaft.
- A3. A working engine completes thousands of revolutions per minute.

Teaching Point 4

Explain That all Engine Operations Must Proceed in Order

Time: 10 min

Method: Interactive Lecture

Engine operations must proceed precisely in order. Often, more than one operation must happen simultaneously. For example, the spark must be delivered to the cylinder while both valves are closed. A spark delivered to a charged cylinder when a valve is open results in a “backfire”. Power is lost and a valve will be burned – or perhaps even broken.



Show the cadets a slide or distribute the handout of the four strokes of a four-stroke piston-powered engine in [Figure 12H-5](#).

The engine operation must proceed as follows:

- Fuel and air mixture must be available for all cylinders, all the time, in a multi-cylinder engine.
- The intake stroke of the piston must take place with the intake valve open and the exhaust valve closed.
- The compression stroke of the piston must take place with both valves closed.
- Electrical signals must be delivered to spark plugs just before the piston completes the power stroke, when both valves are closed.
- The power stroke of the piston must take place with both valves closed.
- The exhaust stroke of the piston must take place with the exhaust valve open and the intake valve closed.
- The camshaft must push each valve open and closed at the right times.



For smooth operation, the valve and spark timing must be precise for all the cylinders.



Distribute copies of [Figure 12I-1](#) and have the cadets fill in the names of the strokes pictured.

CONFIRMATION OF TEACHING POINT 4

QUESTIONS

- Q1. On which strokes are both valves closed?
- Q2. On which strokes is one valve open?
- Q3. What causes an engine to backfire?

ANTICIPATED ANSWERS

- A1. Both valves are closed on the compression stroke and on the power stroke.
- A2. On the intake stroke the intake valve is open; on the exhaust stroke the exhaust valve is open.
- A3. A backfire can be caused by a spark delivered to a charged cylinder when a valve is open.

Teaching Point 5

Enact the Performance of the Four-stroke Piston-powered Engine

Time: 15 min

Method: In-class Activity

ACTIVITY

OBJECTIVE

The objective of this activity is to have the cadets apply their knowledge of the cycles of a four-stroke piston-powered engine by enacting the cycles in order.

RESOURCES

N/A.

ACTIVITY LAYOUT

N/A.

ACTIVITY INSTRUCTIONS

Organize the cadets into teams of six, consisting of:

- One cadet acting as the piston,
- One cadet acting as the crankshaft,
- One cadet acting as the intake valve,
- One cadet acting as the exhaust valve,
- One cadet acting as the camshaft, and
- One cadet acting as the spark plug.

Have the cadets enact the cycles of a four-stroke piston-powered engine in the following way:

1. Have five cadets form a standing circle around the sitting piston.

2. As the crankshaft calls the stroke in sequence (intake, compression, power and exhaust), the piston lowers and raises both hands accordingly.
3. The camshaft points at each valve, while that valve is supposed to be open.
4. Each valve opens their arms wide when the valve is open and places arms at their sides when the valve is closed.
5. The spark plug claps hands over the piston's head just before the end of the compression stroke (before the piston's hands are completely raised), when both valves are closed.
6. The entire sequence is repeated as fast as possible until a mistake is made.

SAFETY

N/A.

CONFIRMATION OF TEACHING POINT 5

The cadets' participation in the activity will serve as the confirmation of this TP.

END OF LESSON CONFIRMATION

QUESTIONS

- Q1. What is the first stroke of a four-stroke piston-powered engine and what does it do?
- Q2. What is the second stroke of a four-stroke piston-powered engine and what does it do?
- Q3. What is the third stroke of a four-stroke piston-powered engine and what does it do?
- Q4. What is the fourth stroke of a four-stroke piston-powered engine and what does it do?

ANTICIPATED ANSWERS

- A1. The intake stroke draws fuel and air into the cylinder.
- A2. The compression stroke forces the fuel and air into the combustion chamber.
- A3. The power stroke transmits the energy of the exploding fuel to the crankshaft.
- A4. The exhaust stroke cleans the cylinder of exhaust fumes and prepares it for the next intake stroke.

CONCLUSION

HOMEWORK/READING/PRACTICE

N/A.

METHOD OF EVALUATION

N/A.

CLOSING STATEMENT

The four-stroke piston-powered engine has the most complex operation of all the engines that are studied in the Air Cadet Program. This engine type is, by far, the most common that cadets will encounter at the airfield and in many other places, such as in lawn mowers, automobiles and boats.

INSTRUCTOR NOTES/REMARKS

If the squadron has access to a computer and projector, software to demonstrate engine operation can be found at the Website listed under reference C3-086.

REFERENCES

- C3-086 NASA Glenn Research Center. *Engines 101*. Retrieved 21 February 2007, from <http://www.grc.nasa.gov/WWW/K-12/airplane/icengine.html>.
- C3-087 NASA Glenn Research Center. *Propulsion Index*. Retrieved 21 February 2007, from <http://www.grc.nasa.gov/WWW/K-12/airplane/shortp.html>.
- C3-116 A-CR-CCP-263/PT-001/(ISBN 0-9680390-5-7) MacDonald, A. F. and Pepler, I. L. (2000). *From the Ground Up: Millennium Edition*. Ottawa, ON: Aviation Publishers Co. Limited.



ROYAL CANADIAN AIR CADETS
PROFICIENCY LEVEL TWO
INSTRUCTIONAL GUIDE



SECTION 4

EO M232.04 – RECOGNIZE THE FUNCTIONS OF OIL IN A FOUR-STROKE PISTON-POWERED ENGINE

Total Time: 30 min

PREPARATION

PRE-LESSON INSTRUCTIONS

Resources needed for the delivery of this lesson are listed in the lesson specification located in A-CR-CCP-802/PG-001, Chapter 4. Specific uses for said resources are identified throughout the Instructional Guide within the TP for which they are required.

Review the lesson content and become familiar with the material prior to delivering the lesson.

Create a slide or handout of [Figure 12J-1](#).

Copy handouts of [Figure 12K-1](#) for each cadet.

PRE-LESSON ASSIGNMENT

N/A.

APPROACH

An interactive lecture was chosen for TP1 and TP3 to TP5 to introduce the functions of oil in a four-stroke piston-powered engine and to give an overview of them.

An in-class activity was chosen for TP2 as it is an interactive way to provoke thought and stimulate an interest among cadets.

INTRODUCTION

REVIEW

N/A.

OBJECTIVES

By the end of this lesson the cadet shall be expected to recognize the functions of oil in a four-stroke piston-powered engine.

IMPORTANCE

It is important for cadets to learn about the four functions of oil because specific oil is required for the efficient operation and maintenance of engines that are so critical to aviation.

Teaching Point 1**Explain That Oil Lubricates the Engine**

Time: 5 min

Method: Interactive Lecture



Show the cadets a slide or handout of the functions of oil located at [Annex J](#).

Oil plays an important role in the functioning of an aircraft engine. Oil fulfills four important functions:

- Lubricating,
- Sealing,
- Cooling, and
- Flushing.

LUBRICATING

Oil lubricates the engine by creating a smooth surface between parts that rub together, such as the piston when it moves up and down in the cylinder.

Oil is manufactured in different grades and viscosities. The grade of a particular sample of oil is a measure of its ability to maintain its viscosity, or resistance to flow, under extreme temperatures.

The viscosity, or resistance to flow, affects the oil's stickiness. Low-viscosity oil flows more easily than high-viscosity oil. Oil thins as its temperature is raised so the correct grade of oil must be selected for the intended condition when the engine is at operating temperature. Oil that is too thin (too low a viscosity number) at operating temperature will result in low oil pressure and will not protect the engine component surfaces adequately. Oil that is too thick will result in too high an oil pressure and will not be delivered in sufficient quantity when the engine is cold.

A good grade of oil is one in which the changes in viscosity, due to widely varying operating temperatures, are small.



The engine manufacturer specifies what oil to use and this direction must be followed to avoid engine wear.

Cold oil is often too thick to be delivered to the engine component's metal surfaces in sufficient quantity so when an engine is cold it should not be run fast or given a load. An aircraft will often be seen sitting still with the engine and propeller running while the engine oil comes up to temperature, just like a car in the winter.

CONFIRMATION OF TEACHING POINT 1

QUESTIONS

- Q1. How does oil lubricate an engine?
- Q2. Who specifies the correct oil for an engine?
- Q3. What does the viscosity number of oil mean?

ANTICIPATED ANSWERS

- A1. Oil lubricates the engine by creating a smooth surface between parts that rub together.
- A2. The manufacturer of the engine specifies the correct oil to use.
- A3. The viscosity number indicates the oil's resistance to flow; the higher the number the greater the resistance.

Teaching Point 2**Compare Friction and Heat**

Time: 5 min

Method: In-class Activity

ACTIVITY**OBJECTIVE**

The objective of this activity is to have the cadets experience the effects of lubrication.

RESOURCES

Hand cream.

ACTIVITY LAYOUT

N/A.

ACTIVITY INSTRUCTIONS

1. Have the cadets rub their hands together firmly to generate heat and friction.
2. Place a drop of hand cream on the palm of one of the cadets' hands and have them repeat the rubbing exercise.
3. Discuss the experience.
4. Ask cadets if their hands slid easier and felt cooler with hand cream.



Conduct a brief discussion to allow the cadets to share their experience with the class and to reflect on it:

- Did hands slide easier with hand cream? The answer should be yes.
- Did hands feel cooler with hand cream? The answer should be yes.

If a cadet does not agree that hands slide easier and that hot spots disappear when hand cream is applied, have them repeat the experiment. Ensure that hands are rubbed vigorously before hand cream is applied and apply hand cream generously.

SAFETY

N/A.

CONFIRMATION OF TEACHING POINT 2

The cadets' participation in the activity will serve as the confirmation of this TP.

Teaching Point 3**Explain That Oil Seals the Combustion Chamber**

Time: 5 min

Method: Interactive Lecture

SEALING

Oil seals the combustion chamber by preventing the expanding gases from leaking out during the power stroke. It does this by creating a barrier between the engine components so that air and other gases cannot get through. This is especially important in the cylinder, so that the exploding gasoline and air mixture does not escape.

Oil has conflicting demands to meet. A high viscosity (resistance to flow) provides the best seal for the combustion chamber but a low viscosity enables the oil to be delivered in greater quantity to bearing surfaces. The same oil must do both jobs and so the engine manufacturer must consider both of these competing requirements when specifying the viscosity and grade of oil to be used.

CONFIRMATION OF TEACHING POINT 3

QUESTIONS

- Q1. What part of the engine does oil help seal and why?
- Q2. How does oil provide a seal?
- Q3. What conflicting demands must oil meet?

ANTICIPATED ANSWERS

- A1. Oil seals the combustion chamber to prevent the expanding gases from leaking out.
- A2. Oil seals engine parts by creating a barrier between them.
- A3. Oil must be thin enough to flow to bearing surfaces but it must also be thick enough to seal the combustion chamber.

Teaching Point 4**Explain That Oil Cools Hot Spots in the Engine**

Time: 5 min

Method: Interactive Lecture

COOLING

Some parts of the engine get hotter than other parts. Areas near the combustion chamber get particularly hot and need to be cooled. Oil cools hot spots in the engine by carrying heat away and equalizing temperature within the engine. This equalization of temperature also helps to bring a cold engine up to operating temperature quickly.

Oil must maintain its viscosity while near the heat of the combustion chamber and so manufacturers of oil have developed viscosity modifiers that lessen the change of viscosity that results from temperature change. Engine manufacturers take this into consideration when specifying what oil to use.

CONFIRMATION OF TEACHING POINT 4

QUESTIONS

- Q1. What engine parts get particularly hot?

- Q2. How does oil cool hot spots in the engine?
 Q3. What must oil be able to do near the combustion chamber?

ANTICIPATED ANSWERS

- A1. Engine parts near the combustion chamber get particularly hot.
 A2. Oil cools hot spots in the engine by carrying heat away and equalizing temperature.
 A3. Oil must maintain its viscosity while near the heat of the combustion chamber.

Teaching Point 5

Explain That Oil Removes and Holds Particles Harmful to the Engine

Time: 5 min

Method: Interactive Lecture

FLUSHING

Oil flushes the engine. It removes and holds tiny particles and grit, which are harmful to the engine. This means the oil carries away dirt and debris from the engine as it flows through. This is why it is important to change oil at frequent intervals as specified by the engine manufacturer.

As the oil is continuously circulated around the engine it passes through an oil filter. This filter fills with debris and must also be changed at regular intervals to remain effective, just as in a car.



Distribute handouts of [Figure 12K-1](#) and have the cadets fill in the four functions of oil.

CONFIRMATION OF TEACHING POINT 5

QUESTIONS

- Q1. How does oil clean the engine?
 Q2. Who specifies oil change intervals?
 Q3. What component must be changed regularly, as well as the oil, to remain effective?

ANTICIPATED ANSWERS

- A1. Oil removes and holds tiny particles and grit, which are harmful to the engine.
 A2. The engine manufacturer specifies oil change intervals.
 A3. The oil filter must be changed regularly to remain effective.

END OF LESSON CONFIRMATION

QUESTIONS

- Q1. What are the functions of oil in an engine?

Q2. Why must oil be changed according to the engine manufacturer's instruction?

Q3. What conflicting demands must oil meet?

ANTICIPATED ANSWERS

A1. The functions of oil in an engine are lubricating, sealing, cooling and flushing.

A2. Oil must be changed according to the engine manufacturer's instruction to extend engine life.

A3. Oil must be thin enough to flow to bearing surfaces but it must also be thick enough to seal the combustion chamber.

CONCLUSION

HOMEWORK/READING/PRACTICE

N/A.

METHOD OF EVALUATION

N/A.

CLOSING STATEMENT

Oil is of first importance to engine operation and maintenance and, if the manufacturer's directions are followed, it will prolong engine life.

INSTRUCTOR NOTES/REMARKS

N/A.

REFERENCES

C3-116 A-CR-CCP-263/PT-001/(ISBN 0-9680390-5-7) MacDonald, A. F. and Pepler, I. L. (2000). *From the Ground Up: Millennium Edition*. Ottawa, ON: Aviation Publishers Co. Limited.



ROYAL CANADIAN AIR CADETS
PROFICIENCY LEVEL TWO
INSTRUCTIONAL GUIDE



SECTION 5

EO C232.01 – IDENTIFY THE CHARACTERISTICS OF GAS TURBINE ENGINES

Total Time:

60 min

PREPARATION

PRE-LESSON INSTRUCTIONS

Resources needed for the delivery of this lesson are listed in the lesson specification located in A-CR-CCP-802/PG-001, Chapter 4. Specific uses for said resources are identified throughout the Instructional Guide within the TP for which they are required.

Review the lesson content and become familiar with the material prior to delivering the lesson.

Create slides or photocopy the handouts located at [Annexes L, M, N](#) and [O](#) for each cadet.

PRE-LESSON ASSIGNMENT

N/A.

APPROACH

An interactive lecture was chosen for TP1 and TP3 to TP5 to introduce the characteristics of gas turbine engines and give an overview of them.

An in-class activity was chosen for TP2 and TP6 as it is an interactive way to provoke thought and stimulate an interest among cadets.

INTRODUCTION

REVIEW

Review EO M232.01 (Identify Types of Aircraft Engines), to include:

- turbojet engines,
- turbofan engines, and
- turboshaft engines.

OBJECTIVES

By the end of this lesson the cadet shall identify the characteristics of gas turbine engines.

IMPORTANCE

It is important for cadets to know about the characteristics of gas turbine engines because this knowledge will enable them to recognize a variety of propulsion applications and to recognize reasons for the performance differences between various classes of aircraft.

Teaching Point 1**Explain That a Jet Engine Is a Reactive Engine**

Time: 5 min

Method: Interactive Lecture

A jet engine is a reactive engine, which propels itself by ejecting material to create a force, as described by Newton's third law of motion.

Newton's third law states that for every action there is an equal and opposite reaction. All propulsion systems rely on this fact in some way. A jet engine propels itself in one direction by ejecting a fluid (hot gas) in the opposite direction.

The amount of thrust developed by ejecting hot gas depends on the mass and velocity of the material ejected. To develop a lot of thrust, a lot of material must be ejected or else it must be ejected at high velocity. Most of the mass ejected by a jet engine comes from the air, which is scooped up from the atmosphere that the jet is passing through. That scooped air is raised to a high velocity by burning fuel.



Since the jet engine can always get more air, its thrust duration is limited only by the amount of fuel that it has available.

CONFIRMATION OF TEACHING POINT 1**QUESTIONS**

- Q1. What is Newton's third law of motion?
 Q2. What determines the amount of thrust developed by a jet engine?
 Q3. What determines the possible duration of a jet engine's thrust?

ANTICIPATED ANSWERS

- A1. Newton's third law of motion states that for every action there is an equal and opposite reaction.
 A2. The mass and the speed of the ejected material determine the amount of thrust.
 A3. A jet engine's thrust duration is determined by the amount of fuel that it has available.

Teaching Point 2**Make and Operate a Pop Can Hero Engine**

Time: 15 min

Method: In-class Activity

ACTIVITY**OBJECTIVE**

The objective of this activity is to have the cadets build and operate a pop can Hero engine to learn that an equal and opposite reactive force, as described by Newton, can cause an object to spin.

RESOURCES

- Instructions for making a pop can Hero engine located at [Annex L](#).
- Empty pop can with the opener-lever still attached (one per group of four cadets),
- Common nail - one per group,
- String (very light, or dental floss), and
- Bucket or tub of water (one per group).

ACTIVITY LAYOUT

This activity is to be carried out in an area with a waterproof floor covering.

ACTIVITY INSTRUCTIONS

1. Fill tubs half-full of water to refill an empty pop can.
2. Give each group one empty pop can which still has the opening lever attached and bent straight up from the centre.
3. Give each group a metre of very fine string or dental floss.
4. Lay the pop can on its side as shown at [Annex L](#).
5. Using a nail, punch a hole in the side of the pop can near the bottom as shown in Step 1 of [Figure 12L-1](#) (ensure the holes are punched straight).
6. Rotate the pop can and punch one hole every 90 degrees, making four equally spaced holes.
7. Thread the string through the pop can opener-lever.
8. Have the cadets fill their pop can Hero engines with water and suspend them above the tub of water so the water drains into the tub.



The pop can Hero engine is unfinished at this point. The pop can Hero engine should not rotate as the water drains.

9. Now, have the cadets insert the nail back into each hole and bend each hole as shown at step 2 of [Figure 12L-1](#). The holes should all be bent in the same direction, either clockwise or counterclockwise, so that the pop can Hero engine will spin under the equal and opposite reaction of the water draining.
10. Have the cadets refill their pop can Hero engines with water from their buckets and suspend the pop can Hero engines above the buckets with string. This time, while the water drains, the pop can Hero engine will spin.



The velocity of the spin should increase as long as the water continues to drain, if very fine string is used for suspension.

SAFETY

Avoid spilling water on the floor as it may become dangerously slippery.

CONFIRMATION OF TEACHING POINT 2

The cadets' participation in the activity will serve as the confirmation of this TP.

Teaching Point 3

Describe the History of Reaction Engine Development

Time: 10 min

Method: Interactive Lecture

A SHORT HISTORY OF TURBINE ENGINES

150 BC – Hero. An Egyptian philosopher and mathematician, invented a toy (Aeolipile) that used steam to rotate on top of a boiling pot of water. The escaping steam caused a reaction that moved several nozzles arranged on a wheel.

1232 – Battle of Kai-Keng. Chinese soldiers used rockets as weapons to repel the Mongols at the Battle of Kai-Keng. Burning gunpowder and the reaction principle were used to propel the rockets. After Kai-Keng, the Mongols used rockets and it is believed that they brought the technology to Europe.

1500 – Leonardo da Vinci. He drew a sketch of a device, the chimney jack, which rotated due to the movement of smoke and hot gases flowing up a chimney. This device used hot air to rotate a shaft, which turned a spit. The hot air from the fire rose upward to pass through a series of fanlike blades that turned a shaft, which turned the roasting spit.

1629 – Giovanni Branca. He developed a stamping mill for bending metal. His stamping mill used jets of steam to spin a turbine, which rotated a shaft to operate the machinery.

1872 – Dr. F. Stolze. He designed the first true gas turbine engine. His engine used a multi-stage turbine section and a flow compressor. This engine never ran under its own power.

1930 – Sir Frank Whittle. He designed a gas turbine for jet propulsion in England. The first successful use of this engine was in April, 1937. His early work on the theory of gas propulsion was based on the contributions of most of the earlier pioneers of this field.

1939 – Heinkel Aircraft Company. This company flew the first gas turbine jet, the HE178.

1941 – Sir Frank Whittle. He designed the first successful turbojet airplane, the Gloster Meteor. Whittle improved his jet engine during World War II and in 1942, he shipped an engine prototype to General Electric in the United States. America's first jet aircraft was built the following year.

1942 – Dr. Franz Anslem. He developed the axial-flow turbojet, which was used in the Messerschmitt Me 262, the world's first operational jet fighter.

After World War II, the development of jet engines was directed by a number of commercial companies. Jet engines soon became the most popular method of powering high-performance aircraft.

ACTIVITY

OBJECTIVE

The objective of this activity is to have the cadets construct a simple gas turbine that will convert axial gas flow into rotary motion.

RESOURCES

- Instructions for making a single-element reaction turbine located at [Annex M](#),

- Scissors,
- Straight pin, and
- Pencil with eraser.

ACTIVITY LAYOUT

N/A.

ACTIVITY INSTRUCTIONS

1. Cut out the rectangle shown in [Figure 12M-1](#). Next, cut along each dotted line stopping about two centimetres from the hole in the centre of the square.
2. Take a straight pin and punch a hole in the top left corner of each of the four flaps. (No two holes should be next to each other.)
3. Pick up a flap at a punched corner and carefully curve it over toward the centre hole, securing it with the pin. Repeat this for the other flaps.
4. When all four flaps are held by the pin, carefully lift the paper without letting the flaps unfurl.
5. Lay the pencil flat on a table and carefully push the point of the pin into the side of the eraser.



Cadets can make the turbine spin by blowing directly into the centre of the blades. This action converts the axial movement of the air into rotary motion of the turbine blades.



The rotary motion of the turbine can be used for many purposes such as operating an air compressor or an electrical generator.

CONFIRMATION OF TEACHING POINT 3

QUESTIONS

- Q1. What was the earliest known use of hot gases to produce rotary motion?
- Q2. What did Leonardo da Vinci use hot gases to produce rotary motion for?
- Q3. What aircraft was the first to fly with a gas turbine jet?

ANTICIPATED ANSWERS

- A1. In 150 BC, Hero, an Egyptian philosopher and mathematician, used hot gases in a rotary toy.
- A2. Leonardo da Vinci used hot gases to produce rotary motion for cooking food on a spit.
- A3. The Heinkel HE178 was the first to fly with a gas turbine jet.

Teaching Point 4**Explain the Advantages of Using a Turbine**

Time: 5 min

Method: Interactive Lecture



Show the cadets a slide or distribute a handout of [Figure 12N-1](#).

The earliest jet to fly was a ramjet, the simplest jet engine, which has no moving parts. The speed of the aircraft forces air into the small volume of the engine, increasing air pressure and density. Ramjet application is restricted by the fact that its air compression depends on forward speed. The ramjet develops no static (stationary) thrust and very little thrust in general when travelling below the speed of sound. As a consequence, a ramjet vehicle requires some form of assisted takeoff, such as another aircraft, and so it has been used primarily in guided-missile systems.

In 1930, Sir Frank Whittle's ingenious idea of placing a turbine into the stream of hot exhaust gases allowed the operation of a compressor to solve the problem of running the engine at low speeds or static conditions. This is the secret of the turbojet engine and of all other refinements of the design, such as turboprops, turbofans and turboshafts.



Point out to the cadets the turbine shown in [Figure 12N-2](#) and the absence of a turbine in [Figure 12N-1](#).

Another benefit of turbines in jet engines is that they provide power for all sorts of ancillary flight instruments and other systems. In a modern airliner, turbine power provides everything from radio communications with the air traffic control tower to hot water for the passengers.

CONFIRMATION OF TEACHING POINT 4**QUESTIONS**

- Q1. What was the first type of jet to fly?
- Q2. What is the principle difference between a turbojet and a ramjet?
- Q3. What additional use has been found for turbine power on aircraft besides compressing air?

ANTICIPATED ANSWERS

- A1. The first type of jet to fly was a ramjet, which relied on high speed to compress air for combustion.
- A2. A turbojet can run at low speed or even under static conditions but a ramjet cannot.
- A3. In addition to compressing air, turbines are used to power ancillary systems such as radios.

Teaching Point 5**Identify and Describe the Parts of a Gas Turbine Turbofan Engine**

Time: 5 min

Method: Interactive Lecture



Show the cadets a slide or distribute a handout of [Figure 12O-1](#).

The four basic parts of any gas turbine jet engine are the compressor, combustor, turbine, and nozzle, all of which process air, or core air, which travels through the engine. In the most common gas turbine aircraft engine, the turbofan, there is also the fan, which provides bypass air as well as core air, and a mixer, which combines the core airflow with the bypass airflow. The reduced engine noise levels and the excellent fuel efficiency of the turbofan engine have made it the engine design of choice for most modern commercial applications. Examples of varied turbofan applications are the CF-18's two GE F404 low bypass turbofan engines and the A380 Airbus's four Rolls-Royce Trent 900 high bypass turbofan engines; two dissimilar applications that both favour turbofan technology.

PARTS OF A TURBOFAN ENGINE

Fan. The fan is the first component in a turbofan. The fan pulls air into the engine. The air then splits it into two parts. One part continues through the "core" or centre of the engine, where it is acted upon by the other engine components. The second part "bypasses" the core of the engine, travelling through a duct to the back of the engine where it produces much of the force that propels the aircraft forward.

Compressor. The compressor is the first component in the engine core. The compressor squeezes the air into a smaller volume, increasing its pressure. The air is then forced into the combustor.

Combustor. In the combustor the air is mixed with fuel and ignited, producing high temperature, expanding gases.

Turbine. The high-energy airflow coming out of the combustor goes through the turbine, causing the turbine blades to rotate. The task of the turbine is to convert the linear gas motion into rotary mechanical work to drive the compressor, which then feeds the combustor with high-pressure air.

Nozzle. The nozzle is the engine's exhaust outlet. The hot, high-pressure gases that have passed through the turbine, combined with the colder air that bypassed the engine core, produce a force when exiting the nozzle that acts to propel the engine, and therefore the aircraft, forward. The nozzle may be preceded by a mixer, which combines the high temperature air coming from the engine core with the lower temperature air that was bypassed in the fan. The mixer results in a quieter engine.

Afterburner. In addition to the basic components of a gas turbine jet engine, one other process is occasionally employed to increase the thrust of a given engine. Afterburning consists of the introduction and burning of raw fuel between the engine turbine and the jet nozzle, utilizing the unburned oxygen in the exhaust gas to support combustion. The increase in the temperature of the exhaust gases further increases their velocity as they leave the propelling nozzle, which thereby increases the engine thrust. This increased thrust could be obtained by the use of a larger engine, but this would increase the weight and overall fuel consumption.

CONFIRMATION OF TEACHING POINT 5

QUESTIONS

- Q1. What are the four basic parts of any gas turbine jet engine?
- Q2. In addition to the four basic parts, what two parts are found in a turbofan jet engine?
- Q3. What are two features of the turbofan that make it attractive for modern commercial aircraft?

ANTICIPATED ANSWERS

- A1. The four basic parts of any gas turbine jet engine are compressor, combustor, turbine, and nozzle.
- A2. In addition to the four basic gas turbine jet parts, a turbofan has a fan and a mixer.
- A3. Two features of the turbofan that make it attractive for modern commercial aircraft are noise reduction and fuel efficiency.

Teaching Point 6

Conduct a Crossword Game Based on Jet Power

Time: 15 min

Method: In-class Activity

ACTIVITY

OBJECTIVE

The objective of this activity is to provide the cadets with an opportunity to use the terminology and definitions that have been learned in this lesson.

RESOURCES

- Coin,
- Flip chart, and
- Markers.

ACTIVITY LAYOUT

In the centre of a flipchart, print the word “combustion”.

ACTIVITY INSTRUCTIONS

1. Divide the cadets into two teams.
2. Determine the order of play by flipping a coin.
3. The first team must make a word from terminology presented in this lesson, using a letter from the word “combustion” written on the flipchart in crossword manner.
4. For each letter in the new word the team will get one point.
5. Before the word can be written on the flipchart, the definition for the word must be provided by the team and the instructor must accept both the word and the definition.
6. Subsequent plays can utilize any letters on the flipchart.

7. Any letter reused is worth two points.
8. The object of the game is to get the most points for the most letters in the time allowed.



Ensure that both teams get an equal number of turns.

SAFETY

N/A.

CONFIRMATION OF TEACHING POINT 6

The cadets' participation in the activity will serve as the confirmation of this TP.

END OF LESSON CONFIRMATION

QUESTIONS

- Q1. What determines the amount of thrust developed by a jet engine?
- Q2. What is the principle difference between the operations of a turbojet and those of a ramjet?
- Q3. What are the four basic parts of any gas turbine jet engine?

ANTICIPATED ANSWERS

- A1. The mass and the speed of the ejected material determine the amount of thrust.
- A2. A turbojet can run at low speed or even under static conditions but a ramjet cannot.
- A3. The four basic parts of any gas turbine jet engine are the compressor, combustor, turbine, and nozzle.

CONCLUSION

HOMEWORK/READING/PRACTICE

N/A.

METHOD OF EVALUATION

N/A.

CLOSING STATEMENT

The gas turbine engine has proven so effective and adaptable that it has become one of the most popular solutions for aviation; Air Cadets will see gas turbines used in many applications.

INSTRUCTOR NOTES/REMARKS

N/A.

REFERENCES

- C0-003 (ISBN 0-943210-44-5) Pike, B. and Busse, C. (1995). *101 More Games for Trainers*. Minneapolis, MN: Lakewood Books.
- C3-016 EG-2003-01-108-HQ NASA. (2003). *Rockets: A Teacher's Guide With Activities in Science, Mathematics, and Technology*. Washington, DC: NASA.
- C3-057 (ISBN-10 1-59647-055-0) Sobey, E. (2006). *Rocket-powered Science*. Tucson, AZ: Good Year Books.
- C3-084 NASA Glenn Research Center. *Engines 101 – Ultra-Efficient Engine Technology (UEET)*. Retrieved 21 February 2007, from <http://www.ueet.nasa.gov/Engines101.html#Aeronautics>.
- C3-086 NASA Glenn Research Center. *Engines 101*. Retrieved 21 February 2007, from <http://www.grc.nasa.gov/WWW/K-12/airplane/icengine.html>.
- C3-087 NASA Glenn Research Center. *Propulsion Index*. Retrieved 21 February 2007, from <http://www.grc.nasa.gov/WWW/K-12/airplane/shortp.html>.
- C3-088 NASA Glenn Research Center. *Beginner's Guide to Rockets*. Retrieved 21 February 2007, from <http://exploration.grc.nasa.gov/education/rocket/bgmr.html>.
- C3-116 A-CR-CCP-263/PT-001/(ISBN 0-9680390-5-7) MacDonald, A. F. and Pepler, I. L. (2000). *From the Ground Up: Millennium Edition*. Ottawa, ON: Aviation Publishers Co. Limited.



ROYAL CANADIAN AIR CADETS
PROFICIENCY LEVEL TWO
INSTRUCTIONAL GUIDE



SECTION 6

EO C232.02 – IDENTIFY THE CHARACTERISTICS OF ROCKET ENGINES

Total Time: 90 min

PREPARATION

PRE-LESSON INSTRUCTIONS

Resources needed for the delivery of this lesson are listed in the lesson specification located in A-CR-CCP-802/PG-001, Chapter 4. Specific uses for said resources are identified throughout the Instructional Guide within the TP for which they are required.

Review the lesson content and become familiar with the material prior to delivering the lesson.

Create slides or photocopy the handouts located at [Annexes P, Q, R, S and T](#).

PRE-LESSON ASSIGNMENT

N/A.

APPROACH

An interactive lecture was chosen for TP1, TP3, TP4 and TP5 to introduce rocket engines and give an overview of them.

An in-class activity was chosen for TP2 as it is an interactive way to provoke thought and stimulate an interest among cadets.

INTRODUCTION

REVIEW

N/A.

OBJECTIVES

By the end of this lesson the cadet shall be expected to identify the characteristics of rocket engines.

IMPORTANCE

It is important for cadets to know about the characteristics of rockets so that they can understand the Canadian Space Agency's mission to promote the peaceful use and development of space, to advance the knowledge of space through science and to ensure that space science and technology provide social and economic benefits for Canadians.

Teaching Point 1**Explain Aspects of Reactive Thrust Used in Propulsion**

Time: 5 min

Method: Interactive Lecture

Every method of propulsion relies on Newton's third law, which states that for every action there is an equal and opposite reaction. This is most obvious when the original action affects an object that is close in size to the object that the reaction affects, such as when a swimmer pushes a floating object. In that case, the swimmer is pushed backward when the object is pushed forward.

However, when the object to be pushed is as large as the Earth, as in the case of a person taking a step forward, it is not so obvious that the Earth moves in the opposite direction when the step is taken. Yet the tiny motion of the Earth is in the opposite direction. The difference in the amount moved is proportional to the difference in weight between the Earth and the walker, so that the reaction is equal, as well as opposite.

In that same way, a wheeled vehicle such as an automobile pushes on the Earth when it begins its journey. Since the automobile is much smaller than the Earth, the smaller mass of the automobile moves much more than the great mass of the Earth. The swimmer, the person walking and the wheeled automobile are all relying on traction to propel them forward.

Newton's third law of motion also dictates the movement of propeller-driven aircraft and jet aircraft. The forward motion of aircraft depends on pushing gases backward instead of pushing the Earth backward. A propeller pushes air backwards and this is called prop wash. A jet engine ejects hot exhaust gases backwards. To move in any direction, all objects and all creatures, whether living or artificial, must push matter of some sort in the opposite direction.



Newton's third law of motion states that for every action there is an equal and opposite reaction. The third law can be correctly interpreted to mean that for every desired reaction there must be an equal and opposite action.

CONFIRMATION OF TEACHING POINT 1

QUESTIONS

- Q1. What does Newton's third law of motion state?
- Q2. Why does the Earth not seem to move backwards when a person steps forward?
- Q3. What does a propeller-driven aircraft create to move forward?

ANTICIPATED ANSWERS

- A1. Newton's third law of motion states that for every action there is an equal and opposite reaction.
- A2. The Earth does move when a person steps forward, but the ratio of the weight of the Earth versus the weight of the person is so great that the movement of the Earth is too small to be seen.
- A3. A propeller-driven aircraft creates prop wash to move forward.

Teaching Point 2**Explore Newton's Third Law of Motion by Operating Balloon Rockets**

Time: 20 min

Method: In-class Activity

ACTIVITY**OBJECTIVE**

The objective of this activity is to have the cadets explore Newton's third law of motion by staging and operating balloon rockets.

RESOURCES

- Instructions for staging balloon rockets located at [Annex P](#),
- Balloons,
- String,
- Straw,
- Tape, and
- Paper or Styrofoam cup.

ACTIVITY LAYOUT

This activity requires a large area to suspend a string guidance system. Place the string through two drinking straws and suspend the string horizontally about 1-1/2 metres above the floor with the ends as far apart as possible. Tighten the string.

ACTIVITY INSTRUCTIONS

1. Tape two inflated but untied balloons to the two drinking straws as shown in [Figures 12P-1](#) and [12P-2](#).
2. Cut off the bottom of the paper or Styrofoam cup and place it over the junction between the two balloons so that air cannot escape from the second stage until the first stage is spent and jettisoned.
3. Release the first stage balloon and allow the two-stage rocket to travel as far as possible down the guidance string.



Point out to the cadets that the air ejected from the balloon causes the balloon to accelerate forward according to Newton's third law of motion. Point out that the energy involved came from cadets when they puffed hard to inflate the balloons.

SAFETY

N/A.

CONFIRMATION OF TEACHING POINT 2

The cadets' participation in the activity will serve as the confirmation of this TP.

Teaching Point 3**Explain How Rocket Systems Operate in Space**

Time: 5 min

Method: Interactive Lecture

A balloon rocket would work in outer space. The air that is ejected from the balloon would produce the same opposite and equal reaction in space that it does in the Earth's atmosphere, except that form drag from the atmosphere would not slow the balloon's travel. The balloon rocket's performance would be improved in space, without the form drag of air.

A reactive propulsion system can operate by ejecting any material. However, the higher the speed of the ejected material, the greater the resulting propulsive force will be. To raise the velocity of ejection, material is most often heated to create pressure. This has been the preferred solution since Hero used steam to operate his toy Aeolipile (pronounced A – O – lipile).



Show the cadets a slide or distribute handouts of Aeolipile in [Figure 12Q-1](#).

Hero of Alexandria invented a rocket-like sphere called an Aeolipile, in about 150 BC, which used steam as a propulsive gas. Hero mounted it on top of a water kettle. A fire below the kettle turned the water into steam, which travelled through pipes to the Aeolipile. Two L-shaped tubes on opposite sides of the sphere allowed the steam to escape and so gave thrust to the sphere that caused it to rotate.

Heating of the material to be ejected most often involves combustion in contemporary rockets although other methods could be used. Rocket combustion systems operate in space because they are self-contained and require no atmospheric oxygen.



Show the cadets a slide or distribute handouts of Combustion in [Figure 12Q-2](#).

Combustion in a rocket engine or a jet engine requires the rapid oxidization of fuel. A jet engine gets access to oxygen by drawing it from the surrounding air, so that a jet's range is limited to the atmosphere. A rocket develops thrust in much the same way as a jet, but a rocket carries its own oxygen supply. Rocket engines and jet engines both have nozzles to generate thrust.



Show the cadets a slide or distribute handouts of a rocket nozzle in [Figure 12Q-3](#).

A rocket engine uses a nozzle to accelerate hot exhaust to produce thrust as described by Newton's third law of motion. The amount of thrust produced by the engine at any given moment depends on both the amount of gas ejected each second and its velocity. These are determined by the rocket nozzle design.



A rocket works in outer space because it brings everything it needs with it.

The Earth's atmosphere is mostly nitrogen. Oxygen is only a fifth of the atmosphere's composition. Therefore, simply storing air for combustion would waste most of the storage space on unreactive nitrogen. To make good use of storage space, oxygen is stored in more pure forms, including liquid oxygen, or LOX. This gives the rocket engine the ability to operate for a longer period in outer space.

CONFIRMATION OF TEACHING POINT 3

QUESTIONS

- Q1. What must a reactive propulsion system eject to move forward?
- Q2. Why is oxygen stored for a rocket's combustion instead of just air?
- Q3. Why does a contemporary rocket engine heat the material to be ejected?

ANTICIPATED ANSWERS

- A1. A reactive propulsion system can eject any material to move forward.
- A2. Oxygen is stored for combustion instead of air because air is mostly nitrogen.
- A3. A rocket engine heats the material to be ejected to create pressure to raise the velocity of the ejected material.

Teaching Point 4

Explain the Differences Between Solid-fuel and Liquid-fuel Rocket Engine Systems

Time: 10 min

Method: Interactive Lecture

CONSTRUCTION

There are three main categories of rocket engines; liquid rockets and solid rockets.

Liquid rocket propellants, the fuel and the oxidizer, are stored separately as liquids and are pumped into the combustion chamber of the nozzle where burning occurs.

Solid rocket propellants, both fuel and oxidizer, are mixed together to form a composite fuel and then packed into a solid cylinder. Under normal temperature conditions the solid rocket propellants do not burn until exposed to a source of heat provided by an igniter. Once the burning in a solid rocket starts, it proceeds until all the propellant is exhausted.



With a liquid rocket the pilot can stop or modify the thrust by turning off the flow of propellants; but with a solid rocket, the casing must be destroyed to stop the engine.

Liquid rockets tend to be heavier and more complex because of the pumps and storage tanks. The propellants are loaded onto the rocket just before launch. A solid rocket is much easier to handle and can sit for years before firing.



Show the cadets a slide or distribute handouts of [Figure 12R-1](#) (Solid Rocket) and [Figure 12R-2](#) (Liquid Rocket).

VEHICLE APPLICATIONS

Solid rocket engines are used on air-to-air and air-to-ground missiles, on model rockets and as boosters for satellite launchers, including the space shuttle's two solid rocket boosters (SRBs).

Liquid rocket engines are used in the Space Shuttle's main engines to place humans in orbit, on many robot missiles to place satellites in orbit and on several high-speed research aircraft.

FUELS AND OXIDIZATION

In a solid rocket, the fuel and oxidizer are mixed together into a solid propellant, which is packed into a solid cylinder. A hole through the cylinder serves as a combustion chamber. When the mixture is ignited, combustion takes place on the surface of the propellant. A flame front is generated which burns into the mixture. The combustion produces great amounts of exhaust gas at a high temperature and pressure. The amount of exhaust gas that is produced depends on the area of the flame front and engine designers use a variety of hole shapes to control the change in thrust for a particular engine. The hot exhaust gas is passed through a nozzle, which accelerates the flow. Thrust is then produced according to Newton's third law of motion.

In a liquid rocket, stored fuel and stored oxidizer are pumped into a combustion chamber where they are mixed and burned. The combustion produces great amounts of exhaust gas at high temperature and pressure. The hot exhaust is passed through a nozzle, which accelerates the flow. Thrust is produced according to Newton's third law of motion.



Show the cadets a slide or distribute handouts of [Figure 12R-3](#) (Liquid System Rocket).

There are many parts that make up a liquid-fuelled rocket. For design and analysis, engineers group parts which have the same function into systems. There are four major systems in a full scale rocket: the structural system, the payload system, the guidance system and the propulsion system.

CONFIRMATION OF TEACHING POINT 4

QUESTIONS

- Q1. What does the term "composite" solid rocket fuel mean?
- Q2. What operational advantages does a solid rocket have over a liquid rocket?
- Q3. What great operational advantage does a liquid rocket have over a solid rocket?

ANTICIPATED ANSWERS

- A1. A composite rocket fuel has both fuel and oxidizer mixed together.
- A2. A solid rocket weighs less and is less complex.

A3. A liquid rocket can be controlled and shut off after ignition.

Teaching Point 5

Discuss American, Russian, European and Chinese Launch Vehicles

Time: 15 min

Method: Interactive Lecture

Although space-age rocketry is often considered to be in its early stages, there are many launch vehicles to explore. One example each of American, Russian, European and Chinese launchers follow:

American Launch Vehicle – Ares

NASA currently has many launchers that they can match to particular missions. For manned space flight after the space shuttle program, the Ares series of rockets has been developed.



Show the cadets a slide or distribute handouts of [Figure 12S-1](#) (Ares I Launch Vehicle).

Ares I is an in-line, two-stage rocket configuration topped by the Orion crew vehicle and its launch abort system. In addition to the vehicle's primary mission – carrying crews of four to six astronauts to Low Earth Orbit (LEO) – Ares I may also use its 22.5-tonne payload capacity to deliver resources and supplies to the International Space Station, or to “park” payloads in orbit for retrieval by other spacecraft bound for the Moon or other destinations.

The Ares I first stage is a single, five-segment Reusable Solid Rocket Booster (RSRB) derived from the Space Shuttle Program's reusable solid rocket motor, which burns a specially formulated and shaped solid propellant.

The Ares I second, or upper, stage is propelled by a J-2X main engine fuelled with liquid oxygen and liquid hydrogen.



Show the cadets a slide or distribute handouts of [Figure 12S-2](#) (Ares V Launch Vehicle).

The first stage of the Ares V vehicle relies on two, five-segment reusable solid rocket boosters for lift-off. The twin solid rocket boosters of the first stage flank a single, liquid-fuelled central booster element.

The central booster tank delivers liquid oxygen and liquid hydrogen fuel to five RS-68 rocket engines. The RS-68 engines serve as the core stage propulsion for Ares.

Atop the central booster element is an interstage cylinder, which includes booster separation motors and a newly designed forward adapter that mates the first stage with the Earth Departure Stage. A J-2X main engine fuelled with liquid oxygen and liquid hydrogen propels the Earth Departure Stage, the same J-2X engine as is used in the Ares I upper stage.

Russian Launch Vehicle – Proton



Show the cadets a slide or distribute handouts of [Figure 12S-3](#) (Proton Launch Vehicle).

The Proton engines burn a liquid fuel called hydrazine (UDMH) with an oxidizer called Nitrogen Tetroxide. Nitrogen Tetroxide and UDMH burn when they come in contact, without any ignition, so they are said to be hypergolic.

The Proton launch vehicle is currently used for national programs and commercial launches of foreign satellites. Proton is designed as a tandem launch vehicle available in three-stage and four-stage options.

European Launch Vehicle – Ariane 5



Show the cadets a slide or distribute handouts of [Figure 12S-4](#) (Ariane Launch Vehicle).

Ariane 5's cryogenic main stage is referred to as the EPC from its title in French, *Etage Principal Cryotechnique*. The EPC is essentially composed of an aluminum tank with two compartments: one for liquid oxygen and one for liquid hydrogen. Both propellants are produced at plants located inside Europe's Spaceport in French Guiana.

Weighing 37 tonnes each when empty, the SRBs (Solid-Rocket Boosters) provide 1100 tonnes of thrust, roughly 92% of the total thrust at liftoff.

Chinese Launch Vehicles – Changzheng (Long March) Rockets



Show the cadets a slide or distribute handouts of [Figure 12S-5](#) (Changzheng [Long March] Launch Vehicles).

The main stages and the booster rockets of Long March rockets use liquid storable propellants with hydrazine (UDMH) as fuel and nitrogen tetroxide as the oxidizing agent—the same hypergolic system used by the Proton rocket discussed above. The upper stages of Long March CZ-3A and CZ-3B use liquid hydrogen (LH2) as fuel and liquid oxygen (LOX) as oxidizer.

CONFIRMATION OF TEACHING POINT 5

QUESTIONS

- Q1. What family of spacecraft does the Ares family replace?
- Q2. Where are the Ariane 5's LOX and liquid hydrogen produced?
- Q3. What fuel oxidization system does the Proton rocket share with the Long March rockets?

ANTICIPATED ANSWERS

- A1. The Ares rockets replace the Space Shuttle.
- A2. Both propellants are produced at plants located inside Europe's Spaceport in French Guiana.
- A3. Both the Proton and the Long March rockets use hydrazine fuel with nitrogen tetroxide oxidizer.

END OF LESSON CONFIRMATION**QUESTIONS**

- Q1. What does Newton's third law of motion state?
- Q2. Why is oxygen stored for a rocket's combustion instead of just air?
- Q3. What great operational advantage does a liquid rocket have over a solid rocket?

ANTICIPATED ANSWERS

- A1. Newton's third law of motion states that for every action there is an equal and opposite reaction.
- A2. Oxygen is stored for combustion instead of air because air is mostly unreactive nitrogen.
- A3. A liquid rocket can be controlled and shut off after ignition.

CONCLUSION**HOMEWORK/READING/PRACTICE**

N/A.

METHOD OF EVALUATION

N/A.

CLOSING STATEMENT

Of all the methods of propulsion, rockets have the longest history. They also have the most exciting future in helping fulfill the Canadian Space Agency's mission.

INSTRUCTOR NOTES/REMARKS

Website references should be made available for cadets to explore on their own time.

REFERENCES

- C3-016 EG-2003-01-108-HQ NASA. (2003). *Rockets: A Teacher's Guide With Activities in Science, Mathematics, and Technology*. Washington, DC: NASA.
- C3-037 *Space Exploration*. (2006). Retrieved 25 May 2006, from <http://www.space.gc.ca/asc/eng/exploration/exploration.asp>.
- C3-057 (ISBN 10-1-59647-055-0) Sobey, E. (2006). *Rocket-powered Science*. Tucson, AZ. Good Year Books.

- C3-087 NASA Glenn Research Center. *Propulsion Index*. Retrieved 21 February 2007, from <http://www.grc.nasa.gov/WWW/K-12/airplane/shortp.html>.
- C3-088 NASA Glenn Research Center. *Beginner's Guide to Rockets*. Retrieved 21 February 2007, from <http://exploration.grc.nasa.gov/education/rocket/bgmr.html>.
- C3-100 China In Space. *The Long March Space Rockets*. Retrieved 26 February 2007, from <http://www.spacetoday.org/China/ChinaRockets.html>.
- C3-112 Federal Space Agency. *Roket1Show*. Retrieved 26 February 2007, from <http://www.roscosmos.ru/RoketsMain.asp>.
- C3-113 European Space Agency. *ESA Launch Vehicles*. Retrieved 26 February 2007, from <http://www.esa.int/esaCP/index.html>.
- C3-114 NASA. *Countdown! NASA Launch Vehicles and Facilities*. Retrieved 27 February 2007, from <http://www-pao.ksc.nasa.gov/kscpao/nasafact/count1.htm#nasa>.



ROYAL CANADIAN AIR CADETS
PROFICIENCY LEVEL TWO
INSTRUCTIONAL GUIDE



SECTION 7

EO C232.03 – IDENTIFY THE CHARACTERISTICS OF HELICOPTER ENGINES

Total Time:	60 min
-------------	--------

PREPARATION

PRE-LESSON INSTRUCTIONS

Resources needed for the delivery of this lesson are listed in the lesson specification located in A-CR-CCP-802/PG-001, Chapter 4. Specific uses for said resources are identified throughout the Instructional Guide within the TP for which they are required.

Review the lesson content and become familiar with the material prior to delivering the lesson.

Photocopy the handouts located at [Annexes T to W](#) for each cadet. Slides may also be created of the figures in [Annexes T to W](#).

Photocopy handouts of the paper helicopter construction templates and instructions shown in [Figures 12T-2](#) and [12T-3](#) for each cadet.

Obtain a helium-filled balloon for use in TP3.

PRE-LESSON ASSIGNMENT

N/A.

APPROACH

An interactive lecture was chosen for TP1 and TPs 3-6 to introduce characteristics of helicopter engines and give an overview of them.

An in-class activity was chosen for TP2 as it is an interactive way to provoke thought and stimulate an interest among cadets.

INTRODUCTION

REVIEW

The review for this lesson is from EO M232.01 (Identify Types of Aircraft Engines), to include characteristics of turboshaft gas turbine engines.

OBJECTIVES

By the end of this lesson the cadet shall identify the characteristics of helicopter engines.

IMPORTANCE

It is important for cadets to know about the characteristics of helicopter engines because helicopters form a significant part of the Canadian Forces' lift, tactical manoeuvring and Search and Rescue capabilities.

Teaching Point 1

Explain Technological Developments That Made Helicopters Viable

Time: 5 min

Method: Interactive Lecture

Important challenges limited early experiments with helicopters. In particular, suitable engines did not exist in the early years. This was a problem that was not to be overcome until the beginning of the 20th century by the development of internal combustion (gasoline) powered engines. Even then, it was not until the mid-1920s that engines with sufficient power, and with the high power-to-weight ratios suitable for vertical flight became more widely available.

Early engines were made of cast iron and were too heavy for helicopters. Aluminum, a common material used on modern aircraft, was available commercially around 1890, but was extremely expensive. Aluminum was not widely used in aeronautical applications until 1920.

While many additional factors contributed in some way to the lack of progress in achieving successful vertical flight, the development of a practical helicopter had to wait until engine technology could be refined to the point that lightweight engines with considerable power could be built. By 1920, gasoline powered piston engines with higher power-to-weight ratios were more widely available. It then became possible to begin to solve the control problems of vertical flight. The era after 1920 is marked by the development of a vast number of prototype helicopters throughout the world.

CONFIRMATION OF TEACHING POINT 1

QUESTIONS

- Q1. Why were early piston-powered engines too heavy for helicopter applications?
- Q2. What material helped make helicopters and helicopter engines practical in 1920?
- Q3. When did the work to solve vertical flight control problems begin?

ANTICIPATED ANSWERS

- A1. Early piston-powered engines were too heavy because they were made of cast iron.
- A2. In 1920, aluminum allowed frames and engines to be light enough for helicopters.
- A3. The work to solve vertical flight control problems began when effective engines became available after 1920.

Teaching Point 2

Make and Fly a Paper Helicopter

Time: 20 min

Method: In-class Activity

When a helicopter engine loses power under flight, the pilot can auto-rotate the aircraft to the ground.



Show the cadets a slide or distribute a handout of auto-rotation flight versus normal flight in [Figure 12T-1](#).

Auto-rotation is the state of flight where the main rotor is being turned by the action of the wind passing up through the rotor disc instead of being turned by engine power.

To do this the rotor must be released from the engine. This release is provided by a free-wheeling device which allows the rotor to turn even if the engine is not running.

To successfully change the downward flow of air to an effective upward flow during auto-rotation, the pitch angle of the main rotor blades must be reduced. This can be compared to lowering the nose and changing the pitch attitude of a fixed-wing aircraft in order to establish a glide.

ACTIVITY

Time: 15 min

OBJECTIVE

The objective of this activity is to have the cadets fold paper helicopters and then auto-rotate them to the ground to demonstrate that loss of engine power does not necessarily lead to a crash.

RESOURCES

Instructions and the template for folding a paper helicopter shown in [Figures 12T-2](#) and [12T-3](#).

ACTIVITY LAYOUT

N/A.

ACTIVITY INSTRUCTIONS

1. Distribute the instructions and template for paper helicopter construction to each cadet.
2. Have the cadets cut out the paper helicopter and then fold it into shape.
3. Have the cadets stand and drop the helicopters.



Give the paper helicopter a spin before releasing it. This will help establish effective rotor action because, as stated by Newton's first law of motion, every object in a state of uniform motion tends to remain in that state of motion unless an external force is applied to it.

SAFETY

N/A.

CONFIRMATION OF TEACHING POINT 2

The cadets' participation in the activity will serve as the confirmation of this TP.

Teaching Point 3**Explain Why Helicopters Have a Top Speed and Why Helicopter Rotors Have Constant Speed**

Time: 10 min

Method: Interactive Lecture

The most defining characteristic of a helicopter engine is the need to maintain constant rotor speed, or a constant number of revolutions per minute (RPM), as specified by the manufacturer.

If the rotor goes too fast, lift will be lost and damage will result as the blade tips approach the speed of sound and shock waves develop. This is more significant with the long blades associated with rotary wings than it is with the shorter blades of fixed-wing aircraft propellers.

On the other hand, a rotor under load cannot be allowed to slow below the design speed because the blades rely on centrifugal force to stay horizontally extended. Because they are wings, rotor blades experience lift. The lift will cause the rotors to rise to form a “cone” if centrifugal force is insufficient to keep them horizontally extended. As the dangerously slowing rotor blades “cone” upward, lift is lost and a crash becomes imminent.



Using a helium-filled balloon, demonstrate to the cadets that centrifugal force is necessary to flatten the rotor disc as shown in [Figure 12U-1](#).

When the helicopter is at rest, the outer tips of the rotor travel at a speed determined by the length of the blade and the RPM. In a moving helicopter, however, the speed of the blades relative to the air depends on the speed of the helicopter as well as on their rotational velocity. The airspeed of the rotor blade in the forward moving, or advancing, part of its rotation is much higher than that of the helicopter itself. It is possible for this blade tip to exceed the speed of sound, and thus produce vastly increased drag and vibration.



In a moving helicopter, the velocity of the blade tips relative to the air depends on the speed of the helicopter itself, as well as the speed of the blade.



Why the Rotor Can Never Be Allowed To Go Too Fast. If the rotor goes too fast, the tips of the long blades will approach the speed of sound and sonic shock waves will cause both equipment damage and loss of lift.



Why the Rotor Under Load Can Never Be Allowed To Go Too Slow. A rotor under load cannot be allowed to drop below the design speed because the blades rely on centrifugal force to stay horizontally extended. Rotor blades under load are experiencing lift and will rise to form a “cone” if centrifugal force is insufficient to keep them horizontally extended. As the dangerously slowing rotor blades “cone” upward, lift is lost and a crash becomes imminent.



Using the model helicopter, demonstrate to the cadets that one blade is retreating while the other blade is advancing at the same speed. Explain that while the helicopter is motionless on the ground or hovering, the airspeed of the advancing blade will be the same as the airspeed of the retreating blade so that each blade will develop equal lift.



Why a Helicopter Has a Never-Exceed Velocity (VNE). As the helicopter flies faster, the true airspeed of the advancing blade's tip will increase toward the speed of sound and sonic shock waves will cause both equipment damage and loss of lift.



Background Knowledge for the Instructor Only. As well, a moving helicopter experiences a difference in lift between halves of the rotor disc because the airspeed over the advancing blade is greater than the airspeed over the retreating blade. The faster the helicopter flies, the greater this difference of lift, because the true airspeed difference of the blade-tips is twice the helicopter's airspeed. That is, to calculate the true airspeed of each blade, the helicopter's speed must be added to the airspeed of the advancing blade and subtracted from the airspeed of the retreating blade. So, increasing helicopter airspeed causes an increasing dissymmetry of lift, which will cause the machine to roll toward the loss of lift unless it is somehow corrected. This is further complicated by precession of the spinning rotor, which converts the undesired roll into undesired pitch. The usual method of equalizing lift over the advancing and retreating blades is to have greater angle of attack on the retreating blade and less angle of attack on the advancing blade, via "cyclic" pitch control. However, the blades' angle of attack adjustment has obvious limits and can only compensate for very limited airspeed. Therefore, the helicopter's airspeed design limit V_{NE} must never be exceeded, even if the machine is very powerful.

Cyclic pitch control changes the angle of attack of the blades separately, to control the helicopter's flight. Collective pitch control changes the angle of attack of both blades simultaneously to deliver more or less lifting power to the rotary wing.

CONFIRMATION OF TEACHING POINT 3

QUESTIONS

- Q1. Why must a helicopter rotor never be allowed to go too fast?
- Q2. Why must the rotor under load never be allowed to go too slow?
- Q3. Why does a helicopter have a never-exceed speed limit?

ANTICIPATED ANSWERS

- A1. If the rotor goes too fast, the tips of the long blades will approach the speed of sound and sonic shock waves will cause both equipment damage and loss of lift.
- A2. If a rotor goes too slow, it will "cone" due to the lift of the rotary wing.
- A3. A helicopter has a never-exceed speed limit to prevent sonic shock at the blade tips.

Teaching Point 4

Explain How Lift of the Main Rotor Is Changed During Flight

Time: 5 min

Method: Interactive Lecture



To increase the lift of a fixed-wing aircraft, the wing's angle of attack is increased. This is also true of a rotary wing.

Changing the pitch angle on the blades changes the blade angle and lift. With a change in angle of attack and lift comes a change in drag and, therefore, the speed or RPM of the rotors could be affected. As the blades' angle of attack is increased, drag increases and so the rotor speed would decrease if it were allowed. Decreasing the blades' angle of attack decreases drag, and so rotor speed would increase if it were allowed.

To maintain a constant rotor speed, which is essential in helicopter operation, a proportionate change in power is required to compensate for the change in drag. A correlator and/or governor is the most common way to accomplish this. The engine is allowed to speed up or slow down according to the load on the rotor, but the rotor speed remains unchanged.

This feature of rotary-wing flight imposes requirements on helicopter engine design. In the turboshaft engines used on most helicopters, the turbine powering the engine's compressor is separate from the turbine powering the shaft that drives the main rotor.

CONFIRMATION OF TEACHING POINT 4

QUESTIONS

- Q1. How is lift increased with a rotary wing?
- Q2. What else increases when the wing's angle of attack is increased?
- Q3. How does a helicopter engine prevent the rotor from slowing when drag increases?

ANTICIPATED ANSWERS

- A1. Increasing the wing's angle of attack increases lift with a rotary wing.
- A2. Drag increases when the wing's angle of attack is increased.
- A3. A proportionate change in power is required to compensate for the increase in drag.

Teaching Point 5

Explain That Most Helicopters Use Turboshaft Engines

Time: 5 min

Method: Interactive Lecture

Although piston-powered engines are still used in some general-aviation helicopters, most helicopters produced are for military or commercial use and feature gas turbine engines, which have high power-to-weight ratios.



Show the cadets a slide or distribute a handout of the turboshaft engine schematic in [Figure 12V-1](#).

Gas turbines can maintain constant rotor speed separate from the speed of the engine itself and in this configuration they are referred to as turboshaft engines. In particular, an engine designed for turboshaft use will generally have one turbine for the engine's own air compressor and a second, separate turbine for powering the drive shaft, which turns the main rotor. The engine itself, because it has a separate compressor turbine, can speed up or slow down as necessary to provide the right amount of high-velocity exhaust gases for the second turbine, keeping the rotor speed constant.

Turboshaft engines are also used to power tanks and ships as well as having stationary applications.

CONFIRMATION OF TEACHING POINT 5

QUESTIONS

- Q1. Who uses helicopters?
- Q2. What type of engine is found in most helicopters?
- Q3. How many turbines does a turboshaft engine have?

ANTICIPATED ANSWERS

- A1. Most helicopters are used in the military or commercially.
- A2. Most helicopters have gas turbine engines configured as turboshafts.
- A3. A turboshaft engine has two turbines; one for its own compressor and one for the main rotor.

Teaching Point 6**Identify CF Helicopters and Discuss Their Associated Engines**

Time: 10 min

Method: Interactive Lecture



Show the cadets slides of the CF helicopters in [Figures 12W-1 to 12W-5](#). Discuss these machines with them, including the following application information.

CH-149 CORMORANT

The Cormorant has been chosen as Canada's new Search and Rescue (SAR) helicopter. The first of these aircraft entered squadron service in 2002 at 19 Wing Comox, and by Spring of 2004, the entire fleet of 15 Cormorants became fully operational. It has three powerful engines, long-range capability and a large cargo area. Its ice protection system, allowing it to operate in continuous icing conditions, and its ability to withstand high winds, make it ideal for Canada's demanding geography and climate.

The Agusta-Westland CH-149 Cormorant is a fully certified off-the-shelf civilian utility helicopter. It includes search and rescue-specific equipment and physical characteristics and performance requirements to meet Canada's SAR responsibilities. This modification provided reduced procurement costs, a rear-fuselage ramp, a single rescue door with both hoists on one side, and eliminated unnecessary military equipment. Shaped rotor blades, strengthened by titanium strips along the leading edge, allow the CH-149 to improve lift and increase speed, lowering the stall speed and reducing vibration. This enables it to withstand high winds (exceeding 50 knots) and provide superior gust response while carrying out routine tasks of hoisting, starting and stopping.

- Quantity in the CF: 15
- Locations:
 - 9 Wing Gander, NF,
 - 8 Wing Trenton, ON,
 - 14 Wing Greenwood, NS, and
 - 19 Wing Comox, BC.

CH-148 CYCLONE

After a thorough pre-qualification and bid evaluation process, the Government of Canada has selected the H92 proposed by Sikorsky as the winner of the Maritime Helicopter Project. Sikorsky will be awarded two separate, but interrelated contracts. The first contract will cover the acquisition of 28 fully integrated, certified and qualified helicopters with their mission systems installed, and will also include modifications to the 12 Halifax Class ships. The second contract will be for a 20-year in-service support contract that includes a training building, and a simulation and training service.

CH-146 GRIFFON

As Canada's Utility Transport Tactical Helicopter (UTTH), the Griffon provides a robust, reliable and cost-effective capability to conduct: airlift of equipment and personnel, command and liaison flights, surveillance and reconnaissance, casualty evacuation, logistic transport, search and rescue, counter-drug operations, and domestic relief operations.

Griffons are used by Combat Support Squadrons at 3, 4 and 5 Wings to support fighter operations by providing a search and rescue capability and utility transportation support to fighter training and operations.

- Quantity in the CF: 85
- Locations:
 - Bagotville, QC,
 - Cold Lake, AB,
 - Gagetown, NB,
 - Valcartier, QC,
 - Goose Bay, NL,
 - Edmonton, AB,
 - Petawawa, ON, and
 - Borden, ON.

CH-139 JET RANGER

The 14 CH-139 Jet Rangers were purchased in 1981 for use by 3 Canadian Forces Flying Training School at CFB Portage la Prairie, in southern Manitoba, now the Southport Aerospace Centre. They are still in use today by 3 Canadian Forces Flying Training School (3 CFFTS), with upgraded avionics and air conditioning, and are maintained by the Allied Wings consortium which provides the aircraft used by 3 CFFTS.

The CH-139 Jet Ranger is a single-engine, five-seat light helicopter. It is configured with a two-bladed, semi-rigid main rotor and a two-bladed anti-torque tail-rotor. The Jet Ranger is powered by an Allison Model 250-C20B gas-turbine engine de-rated to deliver 317 shaft horsepower at sea-level.

- Quantity in the CF: 14
- Locations: 3 CFFTS Portage la Prairie

CH-124 SEA KING

The Sea King is a ship-based helicopter with both day and night flight capabilities, and is carried aboard many Canadian Maritime Command destroyers, frigates and replenishment ships. The Sea King carries detection, navigation and weapons systems as part of its primary mandate of searching for, locating and destroying

submarines. With its subsurface acoustic detection equipment and homing torpedoes, it is also a versatile surveillance helicopter.

Domestically, Sea Kings have increasingly become responsible for search and rescue operations, disaster relief, and assisting other government departments in carrying out counter-narcotic operations, fisheries and pollution patrols.

The Sea King has also been instrumental in peacekeeping operations. For example, during the deployment of forces to Somalia, the CH-124 provided troops with logistical, medical and ammunition support along with flying overland reconnaissance and convoys. It was, in effect, the only link soldiers had with the ships especially during the initial stages of the deployment.

The Sea King fleet has been heavily committed to the campaign against terrorism, deploying aboard Canadian Navy ships to the Persian Gulf since the autumn of 2001. Sea Kings have conducted hundreds of missions ranging from logistics flights to move personnel and cargo to hailing and boarding suspicious vessels.

- Quantity in the CF: 27
- Locations:
 - 12 Wing Shearwater, NS, and
 - Patricia Bay, BC.

CONFIRMATION OF TEACHING POINT 6

QUESTIONS

- Q1. What engine type is common to all CF helicopters?
- Q2. What is the designation of Canada's new Maritime Helicopter?
- Q3. How many engines does the CH-149 Cormorant have?

ANTICIPATED ANSWERS

- A1. CF helicopters all use turboshaft engines.
- A2. Canada's new Maritime Helicopter is the CH-148 Cyclone.
- A3. The CH-149 Cormorant has three turboshaft engines.

END OF LESSON CONFIRMATION

QUESTIONS

- Q1. What material helped make helicopter engines practical in 1920?
- Q2. Why must a helicopter rotor never be allowed to go too fast?
- Q3. How does a helicopter engine prevent the rotor from slowing when drag increases?

ANTICIPATED ANSWERS

- A1. Aluminum helped make helicopter engines practical in 1920.
- A2. If the rotor goes too fast, the tips of the long blades will approach the speed of sound and sonic shock waves will cause both equipment damage and loss of lift.

A3. A proportionate change in power is required to compensate for the increase in drag.

CONCLUSION

HOMEWORK/READING/PRACTICE

N/A.

METHOD OF EVALUATION

N/A.

CLOSING STATEMENT

Rotary wing aircraft present special challenges for aviation but they offer special capabilities as well, which enable them to make important contributions to the Canadian Forces' lift, tactical manoeuvring and Search and Rescue operations.

INSTRUCTOR NOTES/REMARKS

N/A.

REFERENCES

- C3-050 Department of National Defence. (2006). *Canada's Air Force, Aircraft Main Page*. Retrieved 11 October 2006, from http://www.airforce.forces.gc.ca/equip/equip1_e.asp.
- C3-054 Frost, M. (2004). *Force and Movement: Making a Helicopter*. Retrieved 11 October 2006, from http://www.teacherresourcesgalore.com/physics_files/helicopter.doc.
- C3-055 University of Sydney. *Helicopters. (2006)*. Retrieved 12 October 2006, from <http://alex.edfac.usyd.edu.au/blp/websites/Machan/heli.htm>.
- C3-056 US Centennial of Flight Commission. *Helicopters. (2003)*. Retrieved 12 October 2006, from <http://www.centennialofflight.gov/essay/Dictionary/helicopter/DI27.htm>.
- C3-061 Leishman, J.G. (2000). *A History of Helicopter Flight*. Retrieved 1 November 2006, from <http://www.glue.umd.edu/~leishman/Aero/history/html>.

IDENTIFYING TYPES OF AIRCRAFT ENGINES

Rocket Engines



National Aeronautics and Space Administration (NASA), "Missions" Space Shuttle System (2006). Retrieved 17 March 2007, from http://www.nasa.gov/returntoflight/system/system_SSME.html

Figure 12A-1 Rocket Engine Application

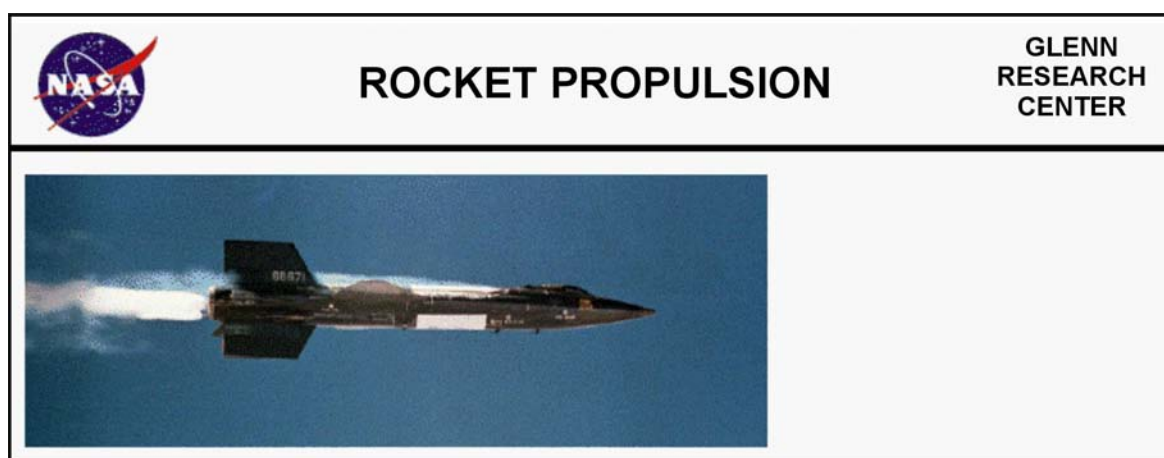

NASA Glenn Research Center. "Propulsion Index". *Rocket Propulsion* (2006). Retrieved 21 February 2007, from <http://www.grc.nasa.gov/WWW/K-12/airplane/shortp.html>

Figure 12A-2 X-15 in Flight

Piston-powered Engines



Canadian Forces. Aircraft. (2005). Retrieved 17 March 2007, from http://www.airforce.gc.ca/equip/equip1_e.asp

Figure 12A-3 Piston-powered Engine Application

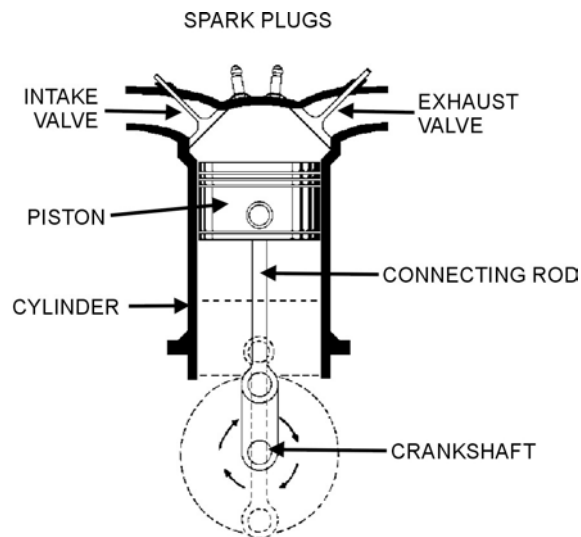

A-CR-CCP-263/PT-001 (p. 53)

Figure 12A-4 Piston-powered Engine Schematic

Jet Engine



Canadian Forces. Aircraft. (2005). Retrieved 17 March 2007, from http://www.airforce.gc.ca/equip/equip1_e.asp

Figure 12A-5 Gas Turbine Engine Application

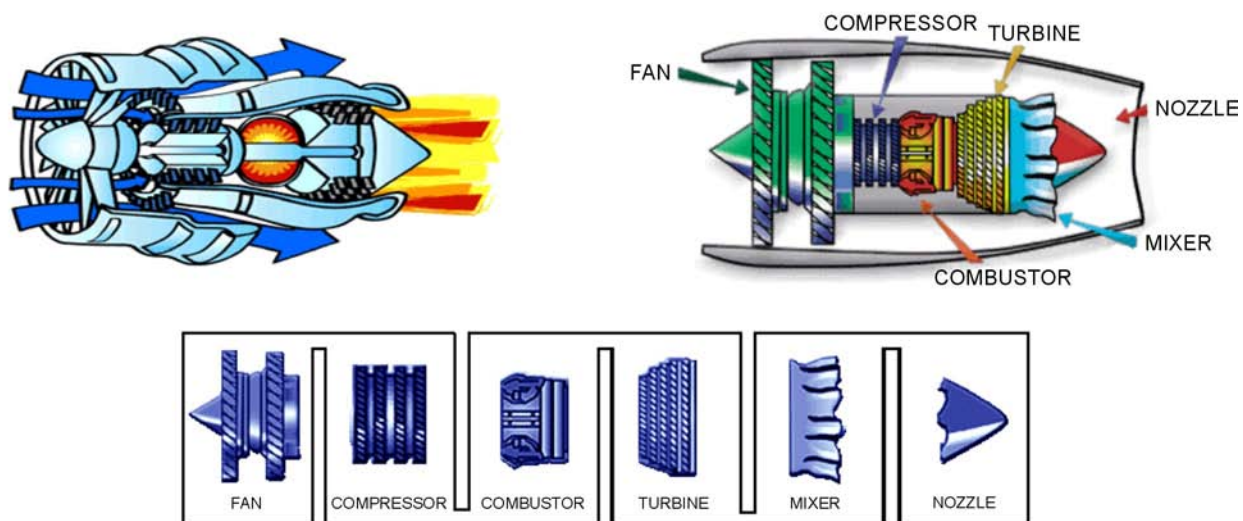

NASA "Engines 101". Ultra Efficient Engine Technology (UEET). (2001). Retrieved 17 March 2007, from <http://www.ueet.nasa.gov/Engines101.html>

Figure 12A-6 Turbofan Parts

Turbojet Engines



Canadian Forces. Aircraft. (2005). Retrieved 17 March 2007, from http://www.airforce.gc.ca/equip/equip1_e.asp

Figure 12A-7 Turbojet Application

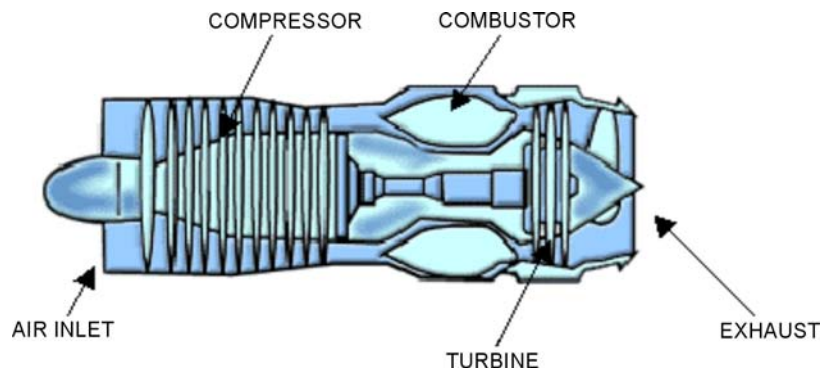

NASA Engines 101. Ultra Efficient Engine Technology (UEET). (2001). Retrieved 17 March 2007, from <http://www.ueet.nasa.gov/Engines101.html>

Figure 12A-8 Turbojet Schematic

Turboprop Engines



Canadian Forces. Aircraft. (2005). Retrieved 17 March 2007, from http://www.airforce.gc.ca/equip/equip1_e.asp

Figure 12A-9 Turboprop Application

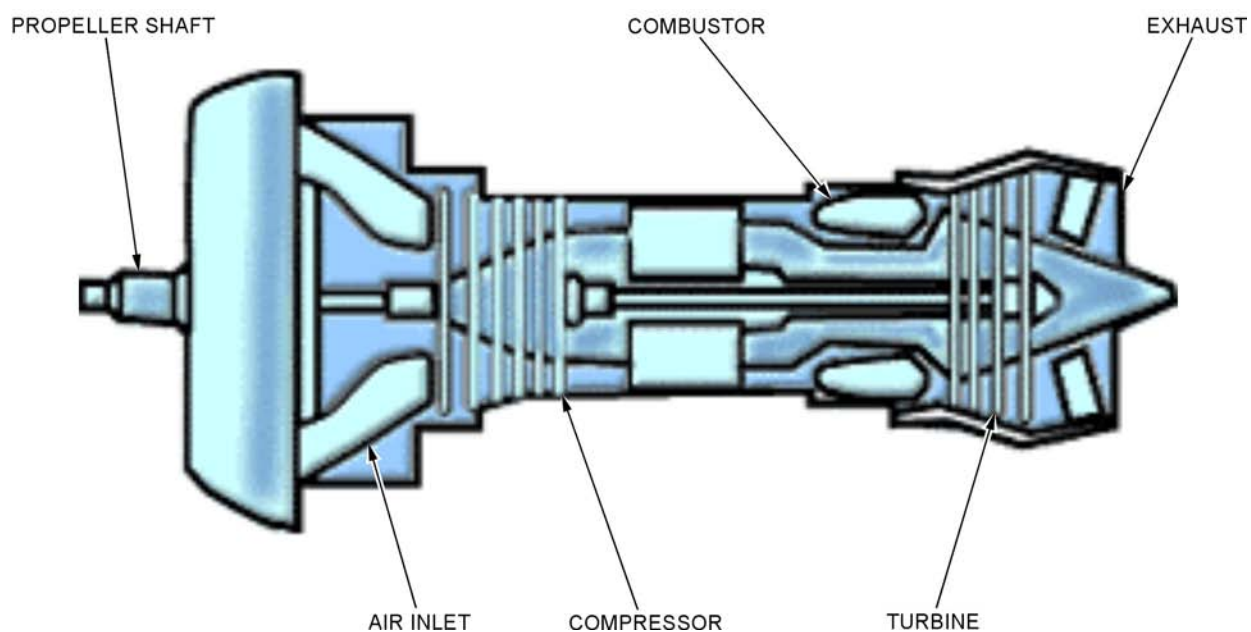

NASA Engines 101. Ultra Efficient Engine Technology (UEET). (2001). Retrieved 17 March 2007, from <http://www.ueet.nasa.gov/Engines101.html>

Figure 12A-10 Turboprop Engine Schematic

Turboshaft Engines



Canadian Forces. Aircraft. (2005). Retrieved 17 March 2007, from http://www.airforce.gc.ca/equip/equip1_e.asp

Figure 12A-11 Turboshaft Engine Application

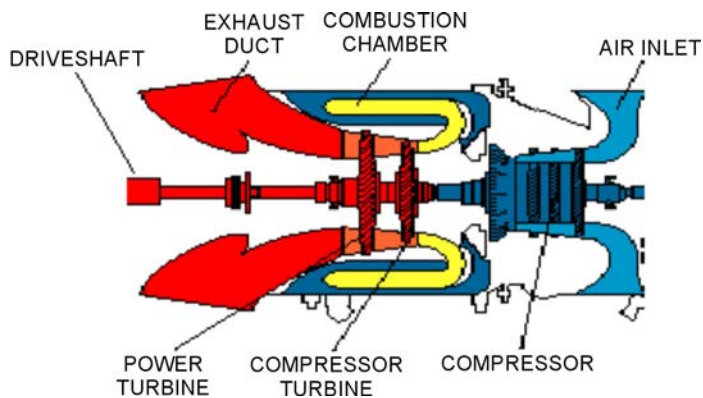

Imagine the Power, Pratt & Whitney Canada. Retrieved 16 March 2007, from http://www.pwc.ca/en/3_0/3_0_3/3_0_3_3_1.asp

Figure 12A-12 Turboshaft Engine Schematic

INTERNAL COMBUSTION



COMBUSTION

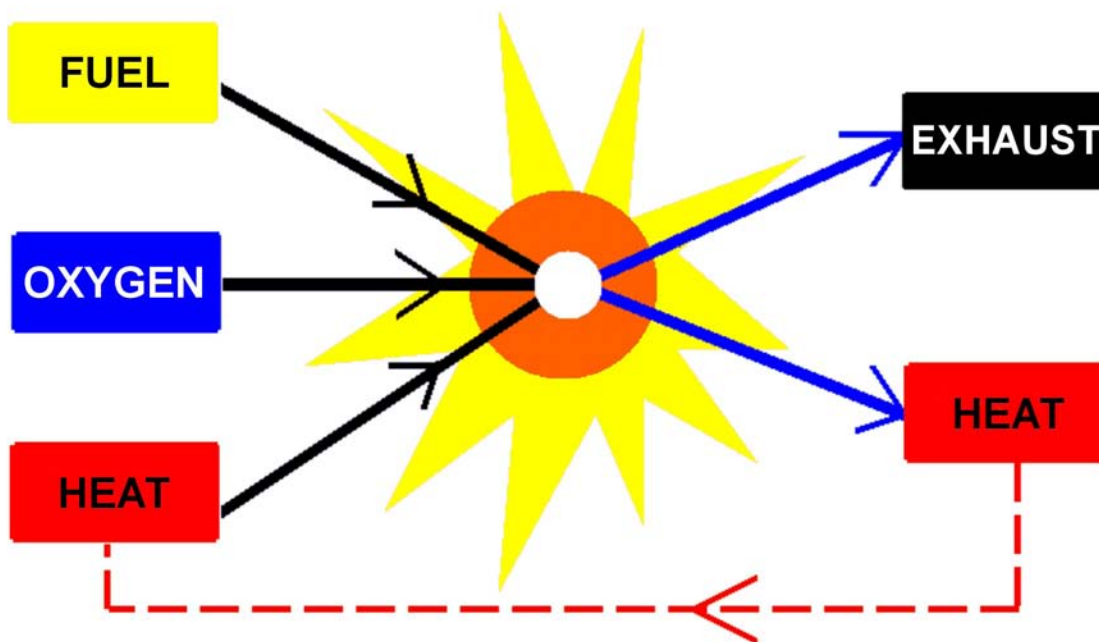

NASA Ultra Efficient Engine Technology (UEET). (2001). Retrieved 17 March 2007, from <http://www.ueet.nasa.gov/Engines101.html>

Figure 12B-1 Combustion

Location of Combustion

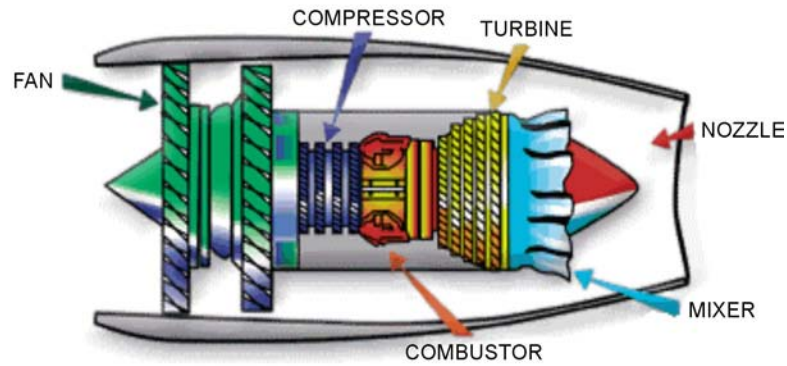

NASA Ultra Efficient Engine Technology (UEET). (2001). Retrieved 17 March 2007, from <http://www.ueet.nasa.gov/Engines101.html>

Figure 12B-2 Combustor Location in a Gas-turbine Engine

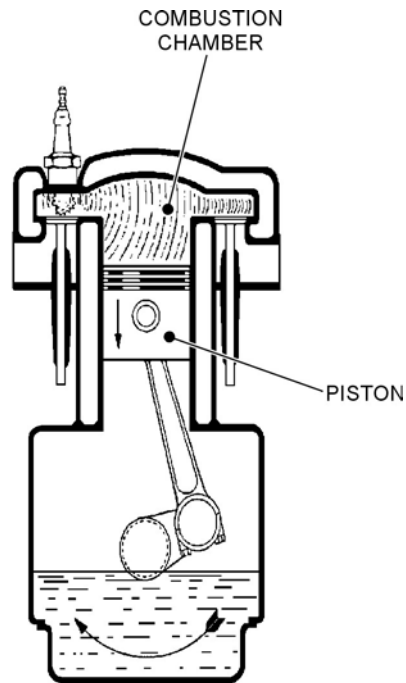

A-CR-CCP-263/PT-001 (p. 53)

Figure 12B-3 Combustion Chamber Location in a Piston-powered Engine

IDENTIFYING COMPONENTS OF PISTON-POWERED INTERNAL COMBUSTION ENGINES

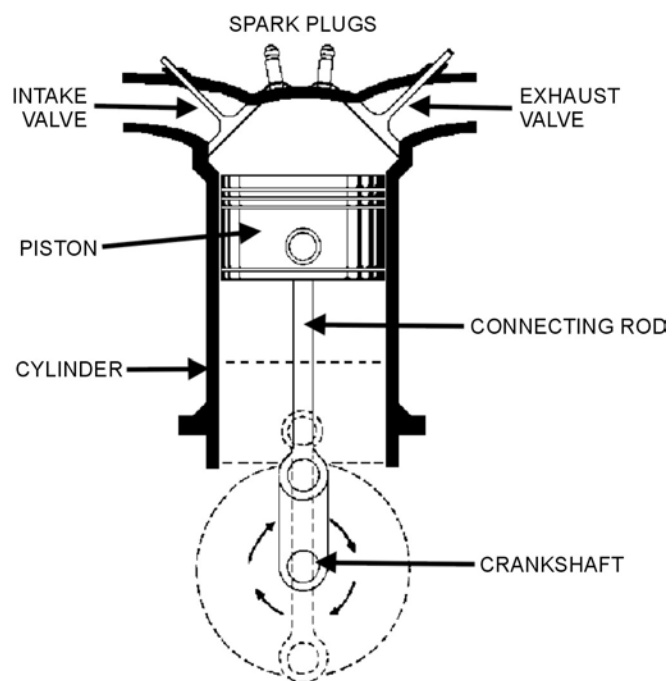

A-CR-CCP-263/PT-001 (p. 53)

Figure 12C-1 Piston-powered Internal Combustion Engine

CARBURETOR

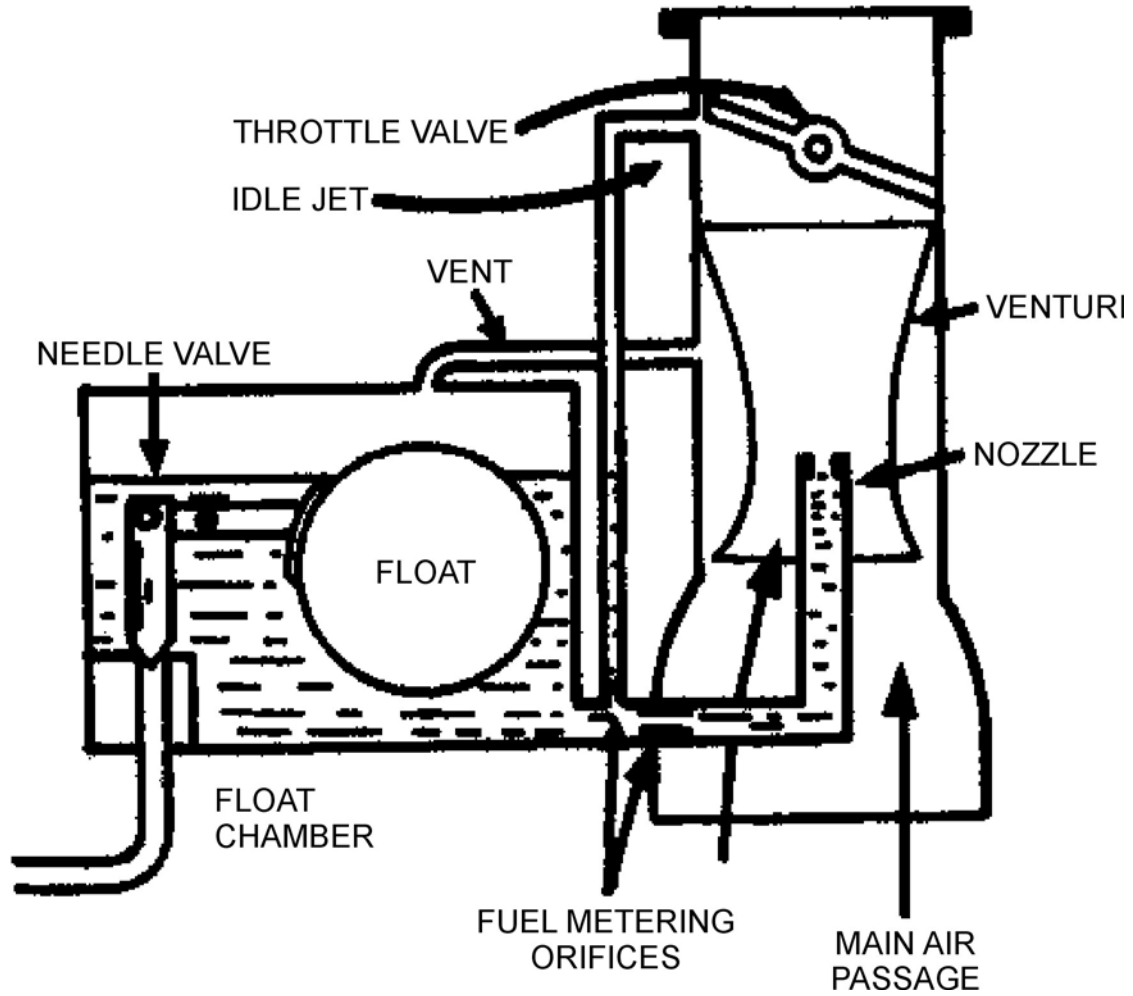

A-CR-CCP-263/PT-001 (p. 62)

Figure 12C-2 Carburetor Components

DRY-SUMP LUBRICATION SYSTEM

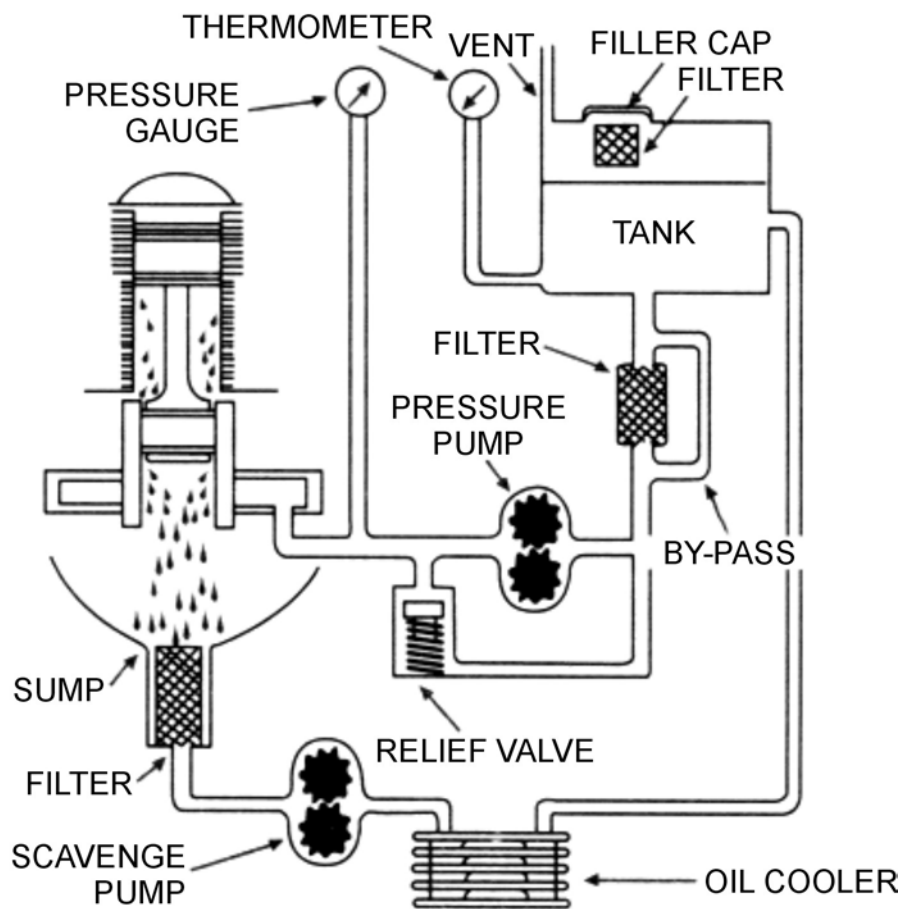

A-CR-CCP-263/PT-001 (p. 62)

Figure 12C-3 Engine Lubrication

FILL IN THE PARTS OF THE INTERNAL
COMBUSTION ENGINE IN THE
CORRECT SPACE.

NAME: _____

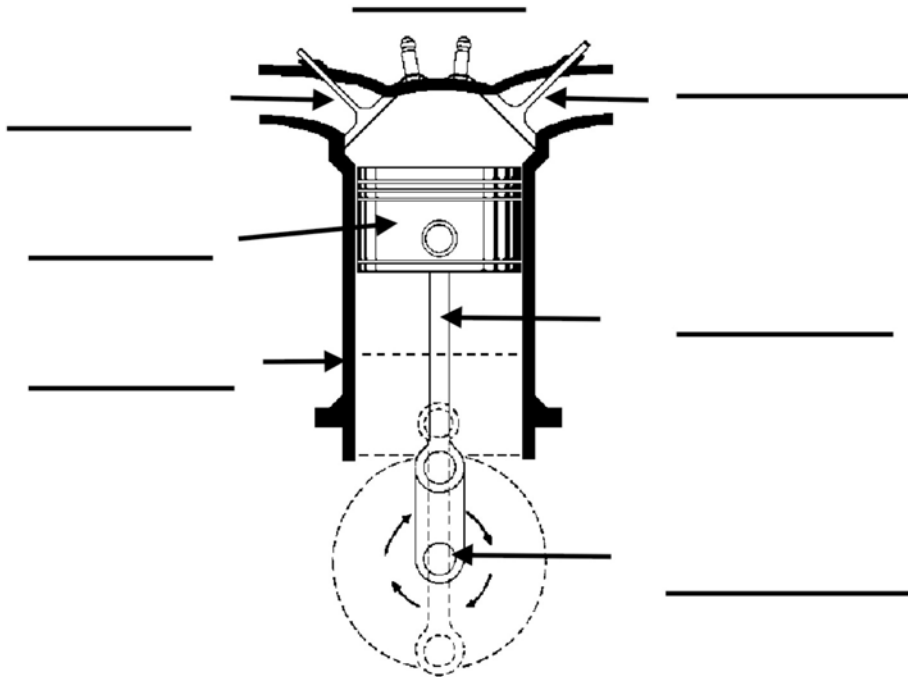

A-CR-CCP-263/PT-001 (p. 53)

Figure 12C-4 Engine Parts Identification

RADIAL ENGINE
RADIAL ENGINE

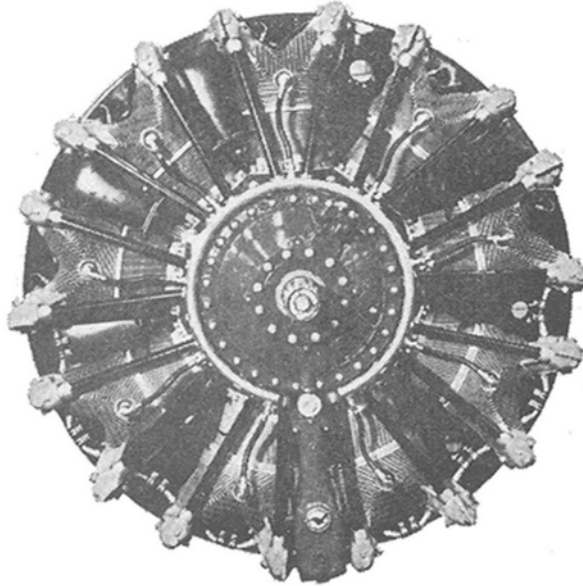

A-CR-CCP-263/PT-001 (p. 52)

Figure 12D-1 Radial Engine Configuration

THIS PAGE INTENTIONALLY LEFT BLANK

HORIZONTALLY OPPOSED ENGINE
HORIZONTALLY OPPOSED

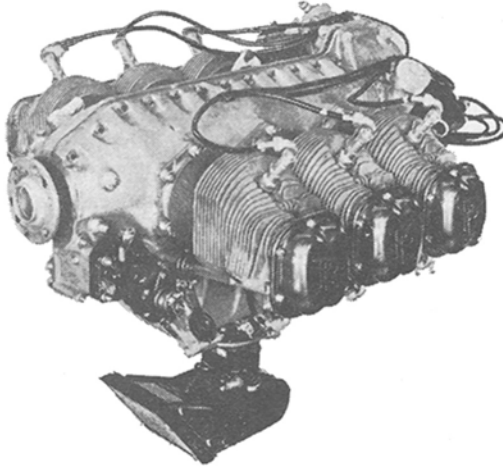

A-CR-CCP-263/PT-001 (p. 52)

Figure 12E-1 Horizontally Opposed Engine Configuration

THIS PAGE INTENTIONALLY LEFT BLANK

IN-LINE ENGINE

IN-LINE

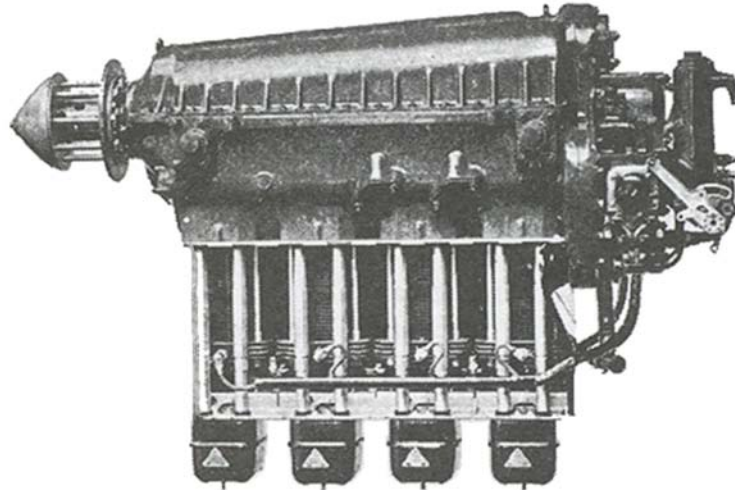

A-CR-CCP-263/PT-001 (p. 52)

Figure 12F-1 In-line Engine Configuration

THIS PAGE INTENTIONALLY LEFT BLANK

QUESTIONS AND ANSWERS FOR TP4 PISTON-POWERED BASEBALL

QUESTIONS

- Q1. Where does combustion take place in a piston-powered engine?
- Q2. What two valves does a piston-powered engine have?
- Q3. Why does the piston go up and down?
- Q4. In a rotary engine which part rotates and which part is stationary?
- Q5. Why was rotary engine design abandoned for aircraft?
- Q6. How were the stationary cylinders arranged in an aircraft's radial engine?
- Q7. How are the cylinders arranged in an in-line engine?
- Q8. How are the cylinders arranged in a horizontally opposed engine?
- Q9. Why are horizontally opposed engines the favoured design for small aircraft engines?

ANTICIPATED ANSWERS

- A1. In a piston-powered engine, combustion takes place in the cylinder.
- A2. Piston-powered engines have an intake valve and an exhaust valve.
- A3. The detonation of the air and fuel mixture drives the pistons up and down.
- A4. In a rotary engine the cylinders rotate and the driveshaft is stationary.
- A5. Rotary engine design was abandoned for aircraft because the great weight of the rotating cylinders was found to interfere with turning the aircraft in flight.
- A6. In radial engines the cylinders were arranged in a circle at the front of the engine with the cylinder tops pointed outwards.
- A7. In an in-line engine, the cylinders are lined up in a row from the front of the engine to the back.
- A8. A horizontally opposed engine has two banks of cylinders lying flat, directly opposite each other.
- A9. The horizontally opposed engine's flat shape generates less form drag.

THIS PAGE INTENTIONALLY LEFT BLANK

ENGINE STROKES

INTAKE STROKE

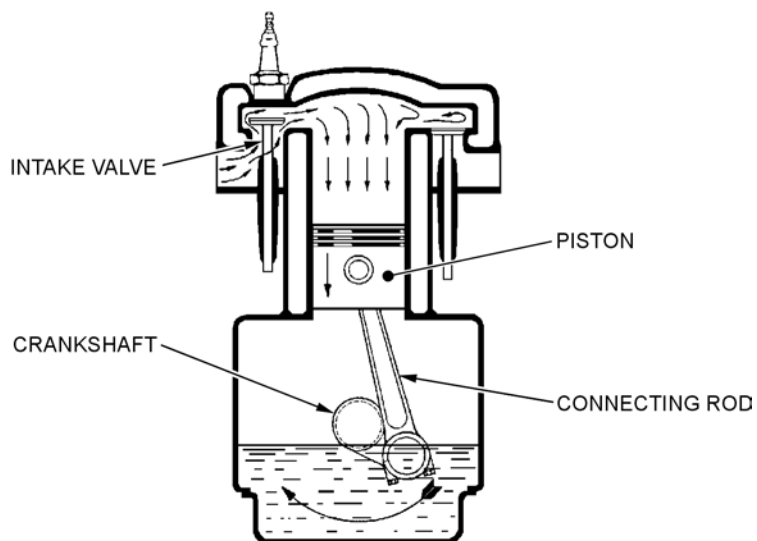

Cadets Canada: RCSU Pacific, 2007, Air Cadet Master Lesson Plans. Retrieved 7 March 2007, from http://www.regions.cadets.ca/pac/aircad/resources/mlp_air_e.asp

Figure 12H-1 Intake Stroke

COMPRESSION STROKE

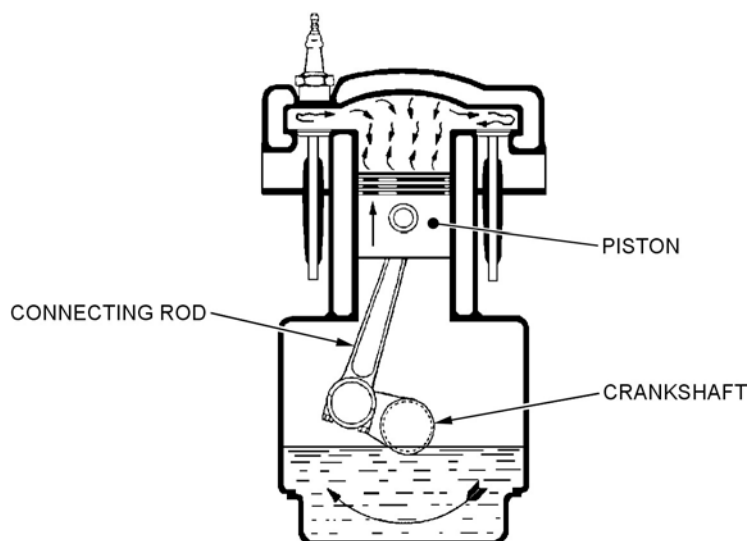

Cadets Canada: RCSU Pacific, 2007, Air Cadet Master Lesson Plans. Retrieved 7 March 2007, from http://www.regions.cadets.ca/pac/aircad/resources/mlp_air_e.asp

Figure 12H-2 Compression Stroke

POWER STROKE

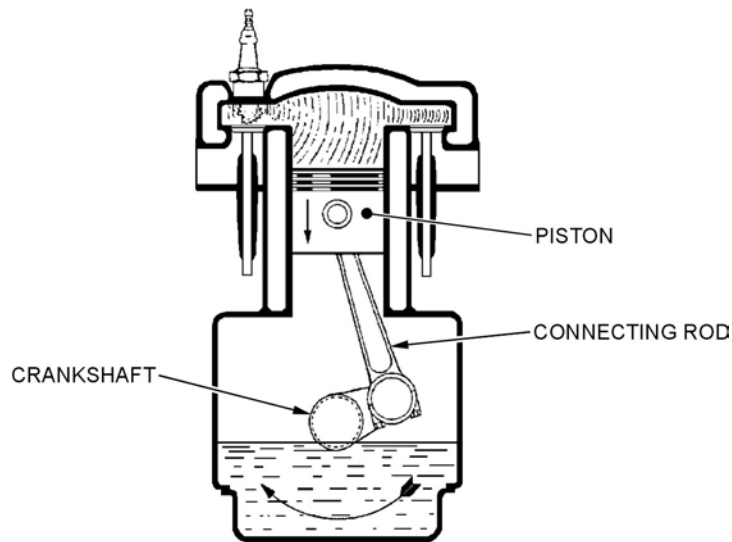

Cadets Canada: RCSU Pacific, 2007, Air Cadet Master Lesson Plans. Retrieved 7 March 2007, from http://www.regions.cadets.ca/pac/aircad/resources/mlp_air_e.asp

Figure 12H-3 Power Stroke

EXHAUST STROKE

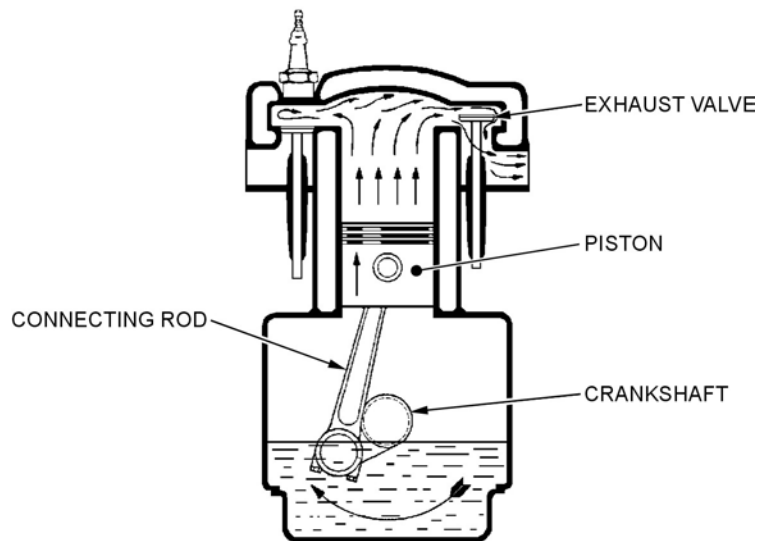

Cadets Canada: RCSU Pacific, 2007, Air Cadet Master Lesson Plans. Retrieved 7 March 2007, from http://www.regions.cadets.ca/pac/aircad/resources/mlp_air_e.asp

Figure 12H-4 Exhaust Stroke

FOUR-STROKE CYCLES

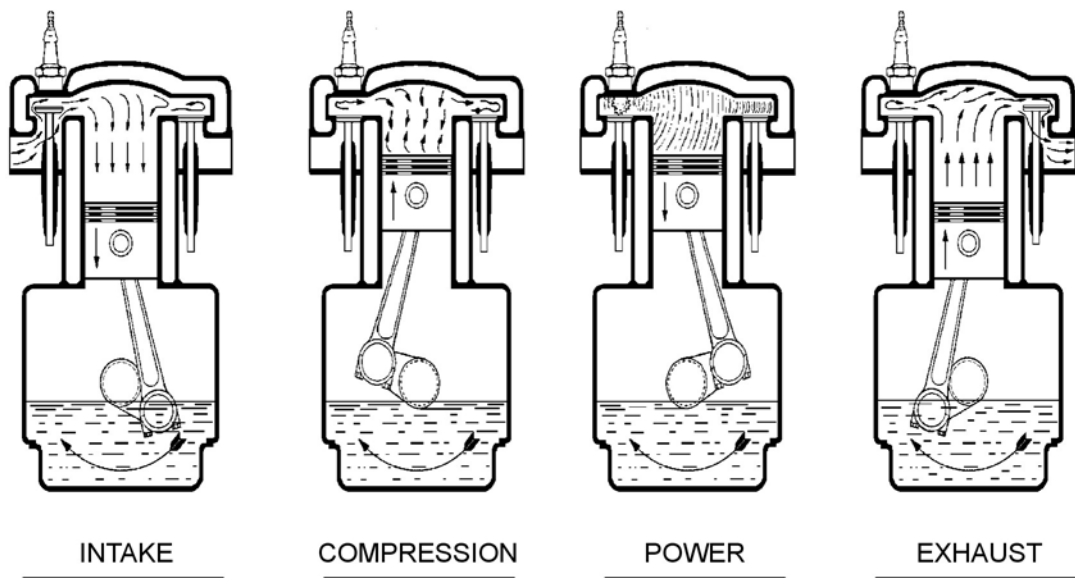

Cadets Canada: RCSU Pacific, 2007, Air Cadet Master Lesson Plans. Retrieved 7 March 2007, from http://www.regions.cadets.ca/pac/aircad/resources/mlp_air_e.asp

Figure 12H-5 Cycles of a Four-stroke Piston-powered Engine

VALVE MECHANISM

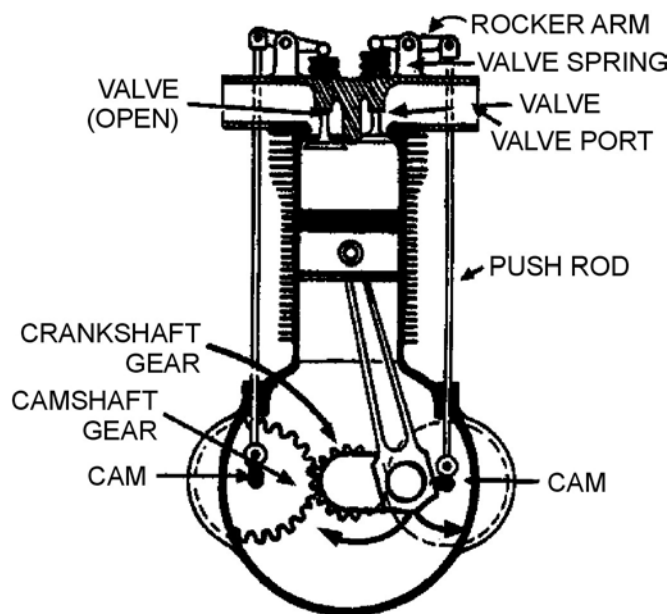

A-CR-CCP-263/PT-001 (p. 56)

Figure 12H-6 Valve Mechanism

THIS PAGE INTENTIONALLY LEFT BLANK

ACTIVITY IDENTIFYING DIFFERENT STROKES

FILL IN THE NAME OF EACH
STROKE IN THE CORRECT SPACE.

NAME: _____

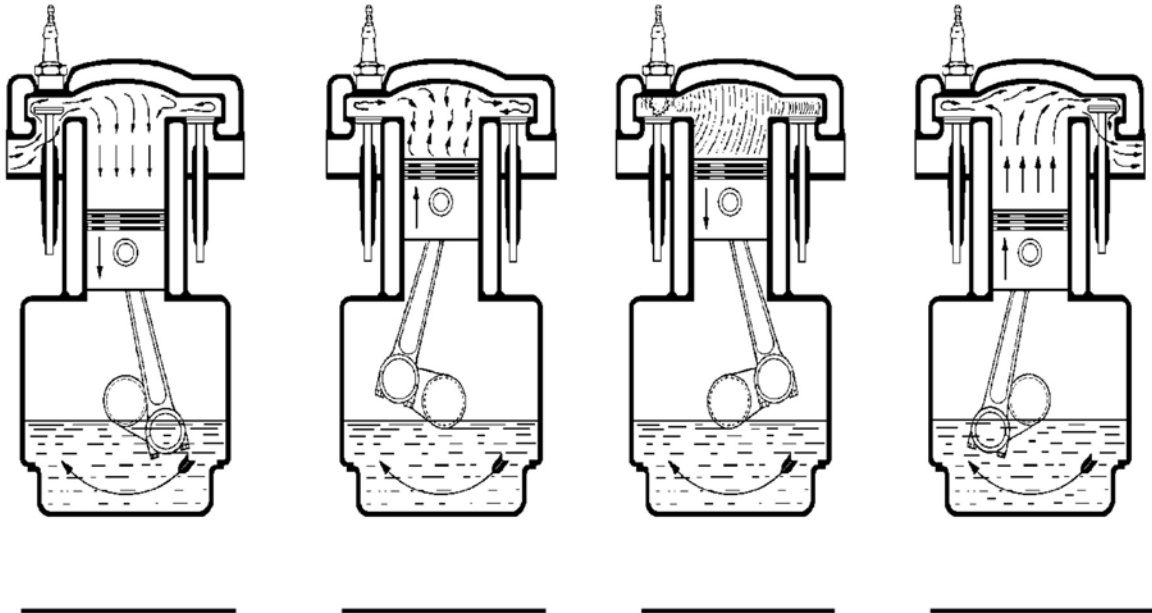

Cadets Canada: RCSU Pacific, 2007, Air Cadet Master Lesson Plans. Retrieved 7 March 2007, from http://www.regions.cadets.ca/pac/aircad/resources/mlp_air_e.asp

Figure 12I-1 Identify the Cycles

THIS PAGE INTENTIONALLY LEFT BLANK

THE FUNCTIONS OF OIL

THE FUNCTIONS OF OIL



1. LUBRICATING

2. SEALING



3. COOLING



4. FLUSHING



Cadets Canada: RCSU Pacific, 2007, Air Cadet Master Lesson Plans. Retrieved 7 March 2007, from http://www.regions.cadets.ca/pac/aircad/resources/mlp_air_e.asp

Figure 12J-1 Oil's Functions

THIS PAGE INTENTIONALLY LEFT BLANK

NAME OIL'S FUNCTIONS

NAME THE FOUR
FUNCTIONS OF OIL.

NAME: _____

1.

2.

3.

4.



Cadets Canada: RCSU Pacific, 2007, Air Cadet Master Lesson Plans. Retrieved 7 March 2007, from http://www.regions.cadets.ca/pac/aircad/resources/mlp_air_e.asp

Figure 12K-1 Name Oil's Functions

THIS PAGE INTENTIONALLY LEFT BLANK

MAKING A POP CAN HERO ENGINE

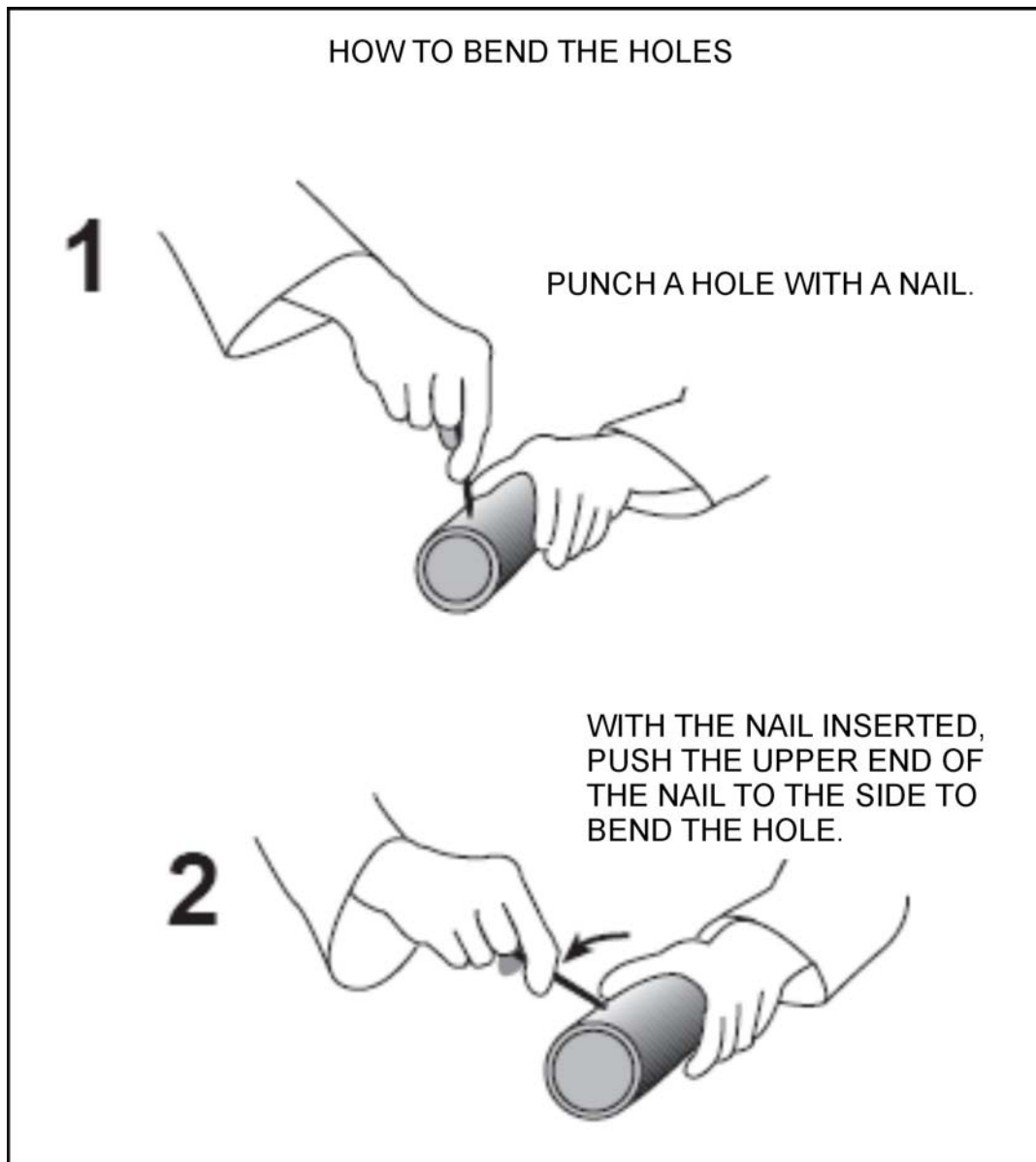

NASA, *Rockets: A Teacher's Guide with Activities in Science, Mathematics and Technology*, NASA (p. 30)

Figure 12L-1 Making a Pop Can Hero Engine

THIS PAGE INTENTIONALLY LEFT BLANK

SINGLE-ELEMENT REACTION TURBINE

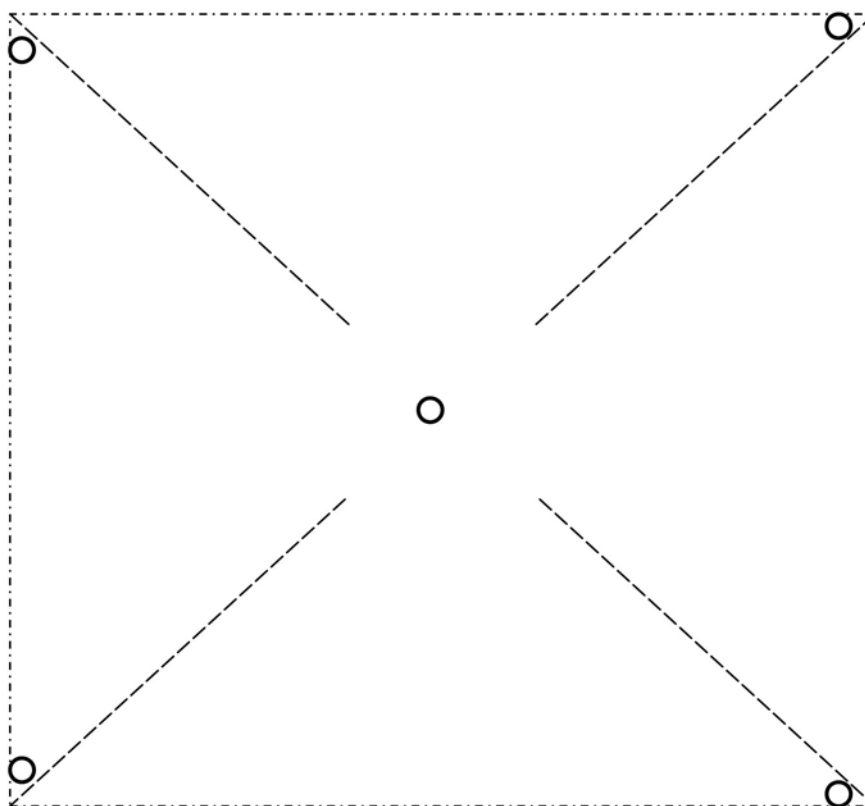

D Cds 3, 2007 Ottawa, ON: Department of National Defence

Figure 12M-1 Single-element Reaction Turbine Template

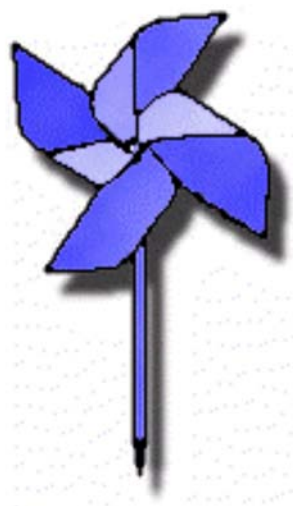

*The Franklin Institute. "Resources for Science Learning" Pinwheel Wind Collector.
Retrieved 21 February 2007, from <http://sln.fi.edu/tfi/units/energy/pinwheel.html>*

Figure 12M-2 Single-element Reaction Turbine

THIS PAGE INTENTIONALLY LEFT BLANK

A RAMJET ENGINE

A RAMJET ENGINE

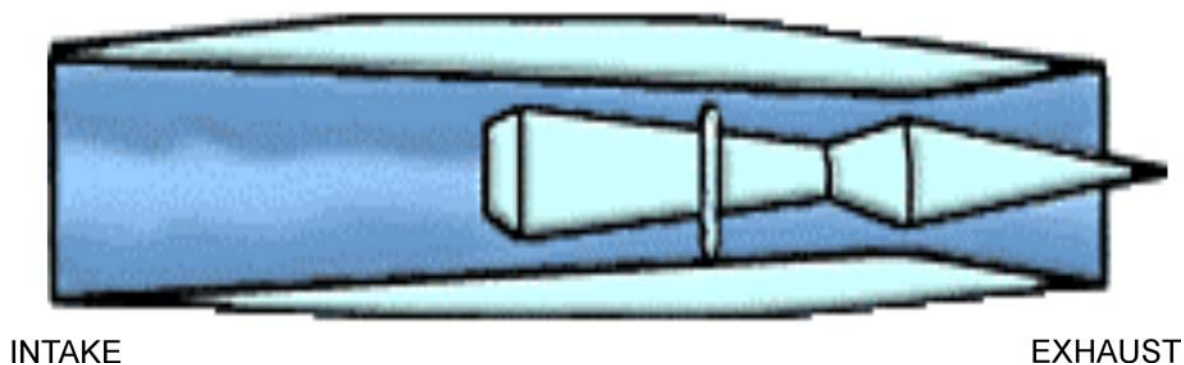

NASA "Engines 101". *Ultra Efficient Engine Technology (UEET)*. (2001).
Retrieved 17 March 2007, from <http://www.ueet.nasa.gov/Engines101.html>

Figure 12N-1 A Ramjet Engine

A TURBOFAN (FANJET) ENGINE

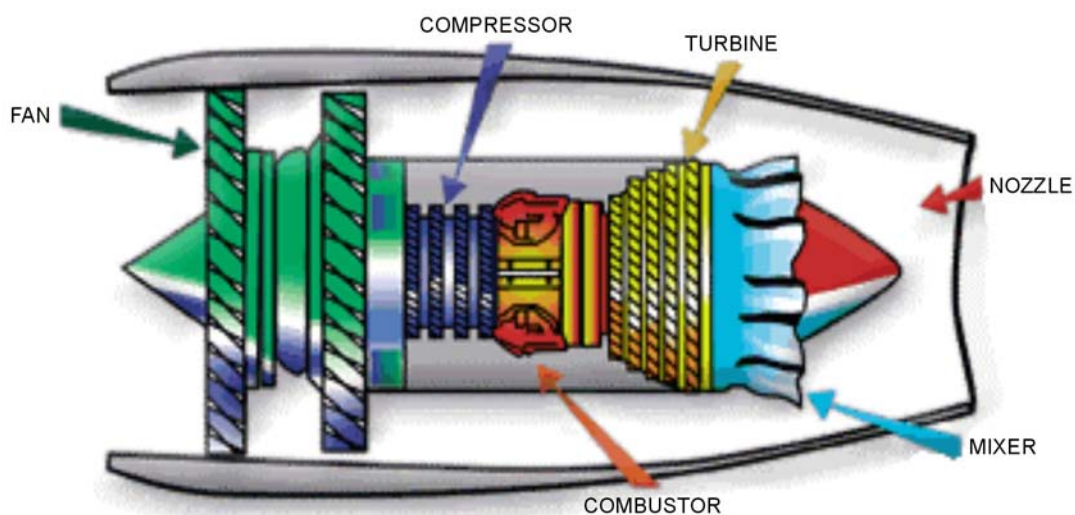

NASA "Engines 101". *Ultra Efficient Engine Technology (UEET)*. (2001).
Retrieved 17 March 2007, from <http://www.ueet.nasa.gov/Engines101.html>

Figure 12N-2 A Fanjet (Turbofan) Engine

THIS PAGE INTENTIONALLY LEFT BLANK

PARTS OF A TURBOFAN (Fanjet) ENGINE

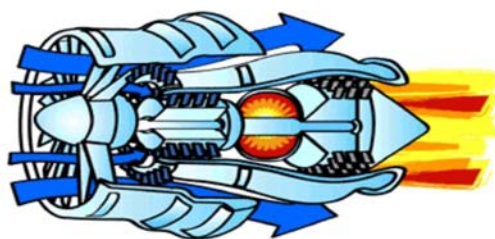
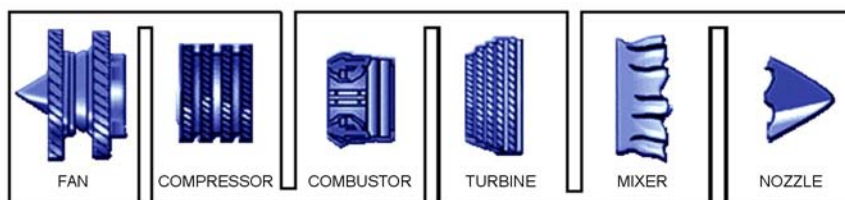
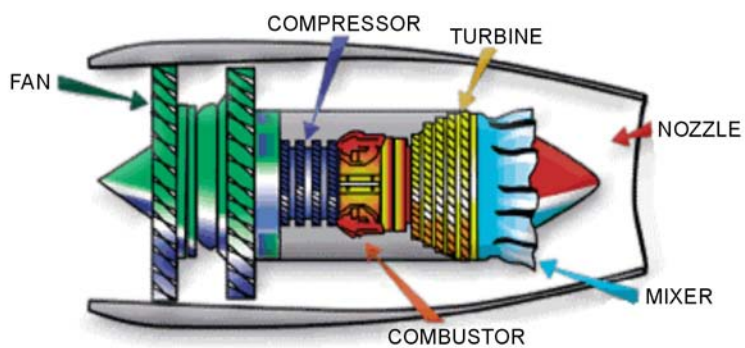

NASA "Engines 101". Ultra Efficient Engine Technology (UEET). (2001).
Retrieved March 17, 2007, from <http://www.ueet.nasa.gov/Engines101.html>

Figure 12O-1 Turbofan Parts

THIS PAGE INTENTIONALLY LEFT BLANK

STAGING BALLOON ROCKETS INSTRUCTIONS

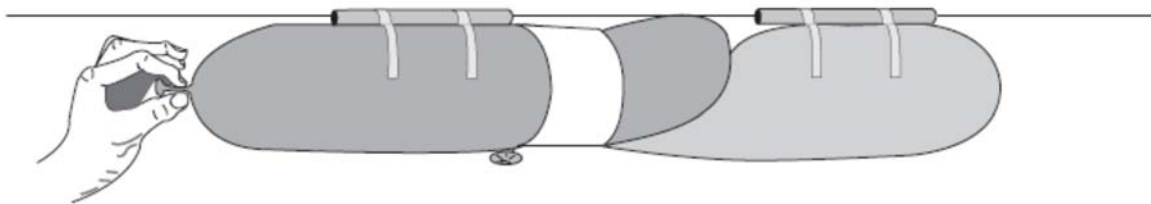

NASA, Rockets: A Teacher's Guide with Activities in Science, Mathematics and Technology, NASA (p. 64)

Figure 12P-1 Staging Balloon Rockets

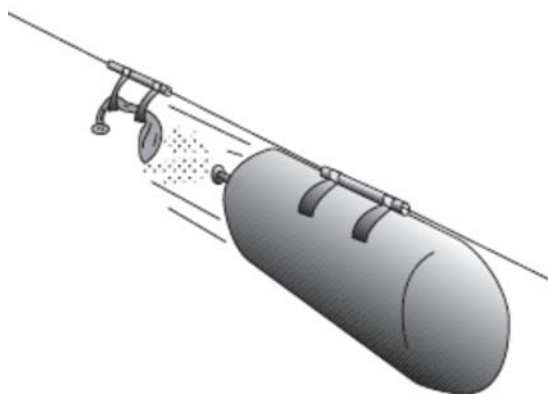

NASA, Rockets: A Teacher's Guide with Activities in Science, Mathematics and Technology, NASA (p. 63)

Figure 12P-2 Jettisoning the First Stage

THIS PAGE INTENTIONALLY LEFT BLANK

ROCKET SYSTEM OPERATION IN SPACE



HERO ENGINE

"Rockets" A Brief History of Rockets. Retrieved 24 March 2007, from http://www.grc.nasa.gov/WWW/K-12/TRC/Rockets/history_of_rocket.html

Figure 12Q-1 The First Reactive Engine



COMBUSTION

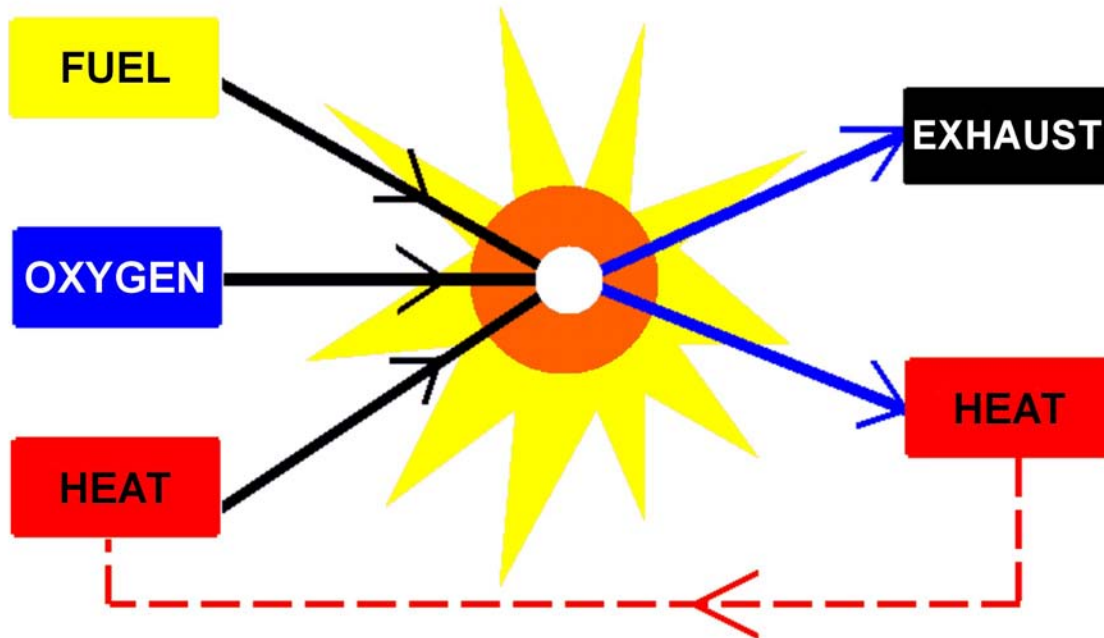

*"Beginner's Guide to Rockets" Combustion. Retrieved 25 March 2007,
from <http://exploration.grc.nasa.gov/education/rocket/combst1.html>*

Figure 12Q-2 Combustion

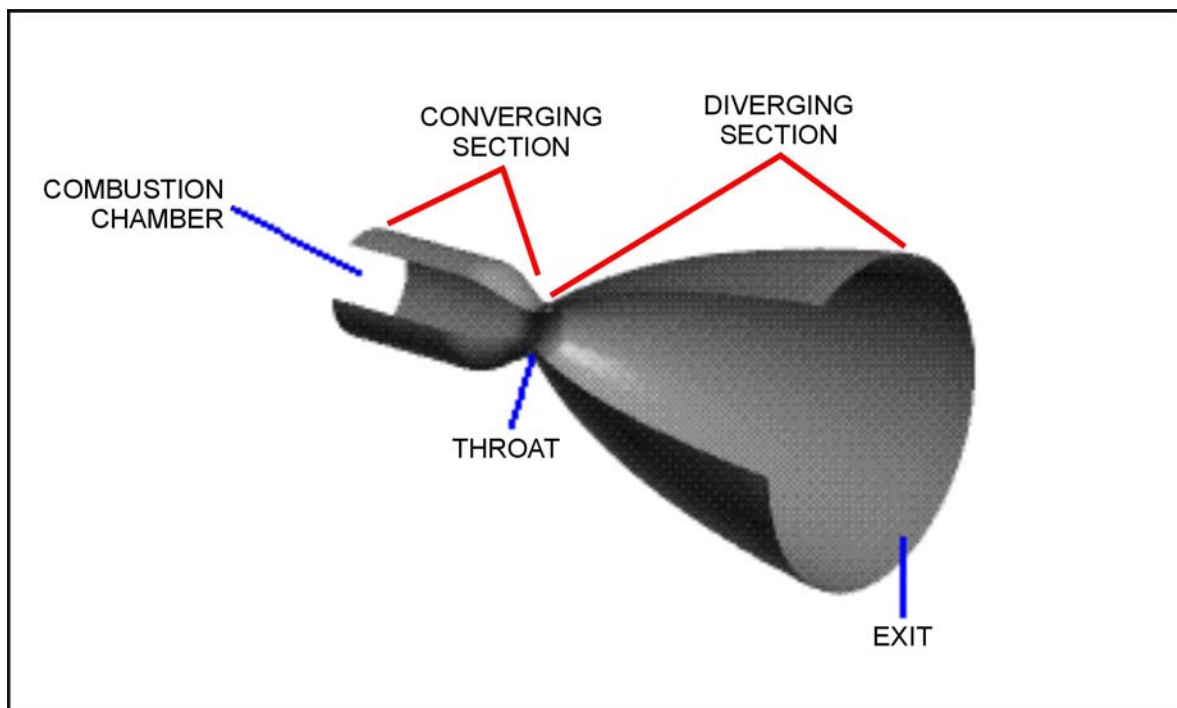

*"Beginner's Guide to Rockets" Combustion. Retrieved 25 March 2007,
from <http://exploration.grc.nasa.gov/education/rocket/nozzle.html>*

Figure 12Q-3 A Rocket Nozzle

THIS PAGE INTENTIONALLY LEFT BLANK

SOLID AND LIQUID ROCKET ENGINES



SOLID ROCKET ENGINE

GLENN
RESEARCH
CENTER

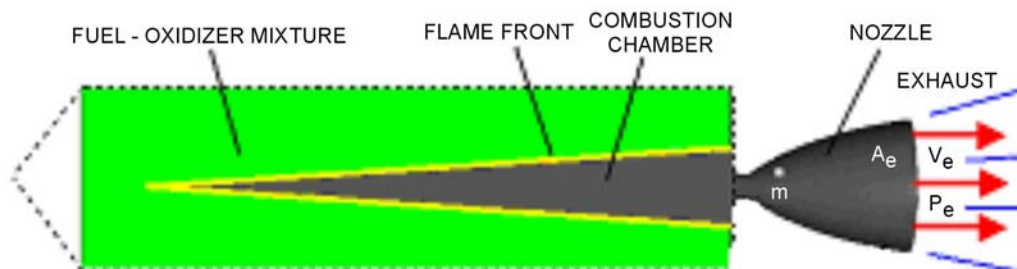

"Beginner's Guide to Rockets" Solid Rockets. Retrieved 25 March 2007, from <http://exploration.grc.nasa.gov/education/rocket/rockth.html>

Figure 12R-1 Solid Rocket Design



LIQUID ROCKET ENGINE

GLENN
RESEARCH
CENTER

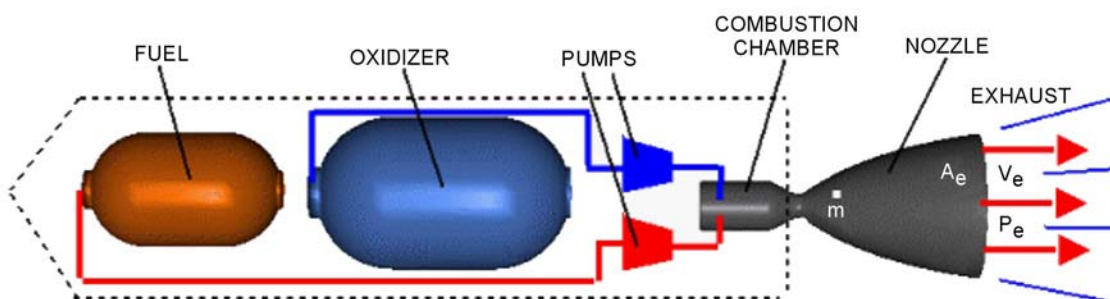

"Beginner's Guide to Rockets" Liquid Rockets. Retrieved 25 March 2007, from <http://exploration.grc.nasa.gov/education/rocket/rockth.html>

Figure 12R-2 Liquid Rocket Design



ROCKET PARTS

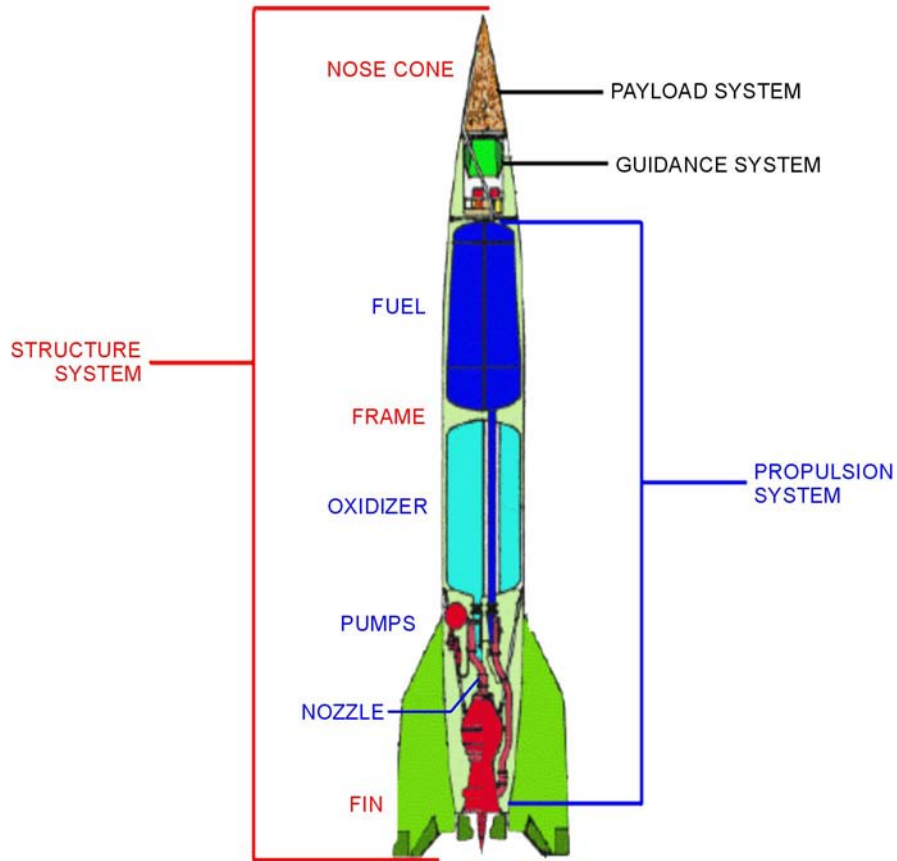

"Beginner's Guide to Rockets" Rocket Parts. Retrieved 25 March 2007, from <http://exploration.grc.nasa.gov/education/rocket/rockpart.html>

Figure 12R-3 Liquid System Rocket

LAUNCH VEHICLES

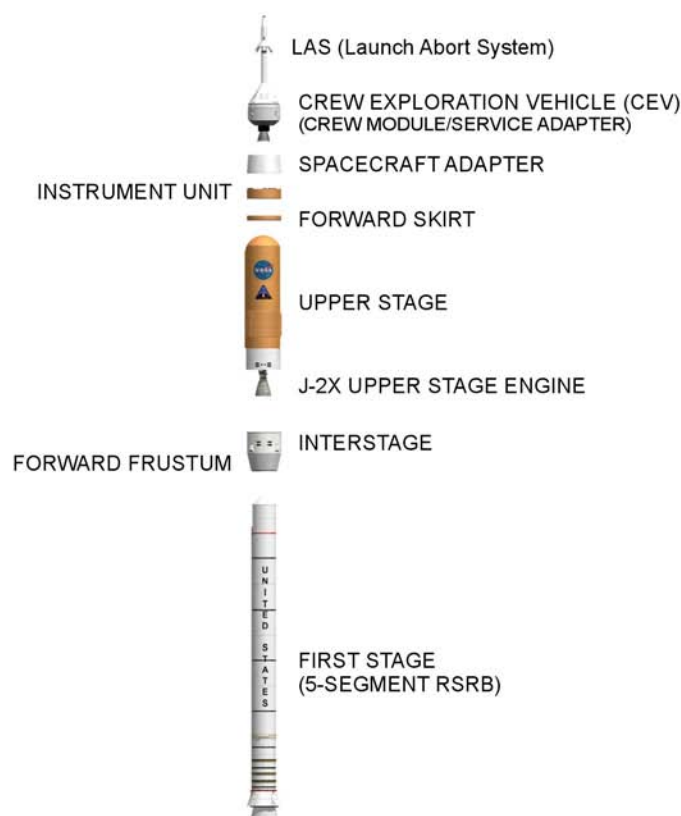

ARES / CREW LAUNCH VEHICLE

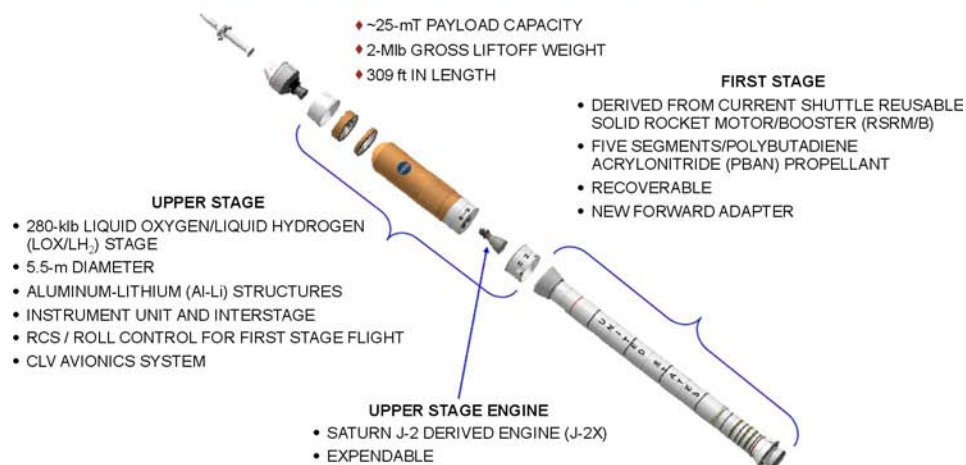

NASA "Constellation Program" Ares Launch Vehicles. Retrieved 24 March 2007, from http://www.nasa.gov/mission_pages/constellation/ares/ares1.html

Figure 12S-1 Ares 1 Launch Vehicle

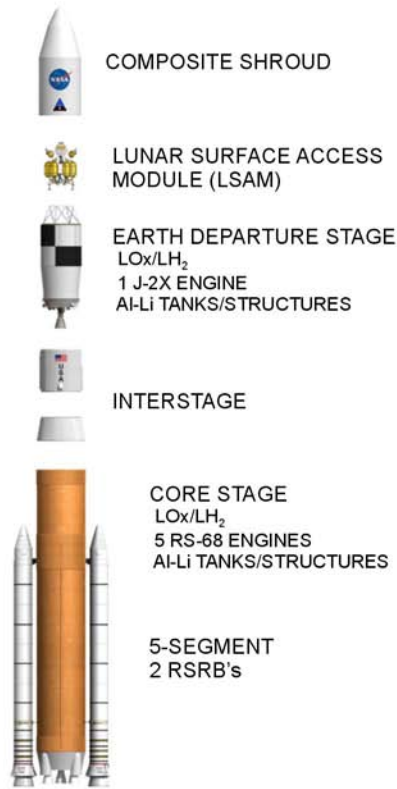

ARES V CARGO LAUNCH VEHICLE

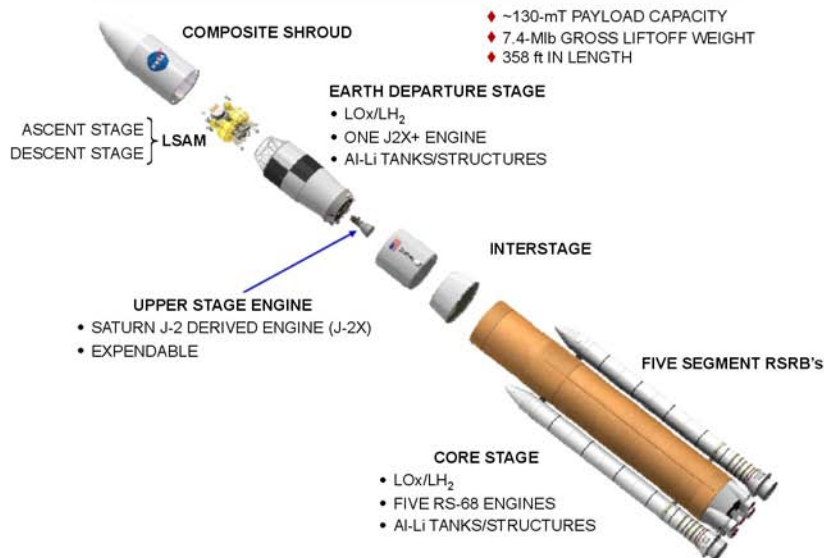

NASA "Constellation Program" Ares Launch Vehicles. Retrieved 24 March 2007, from http://www.nasa.gov/mission_pages/constellation/ares/aresV.html

Figure 12S-2 Ares V Launch Vehicle

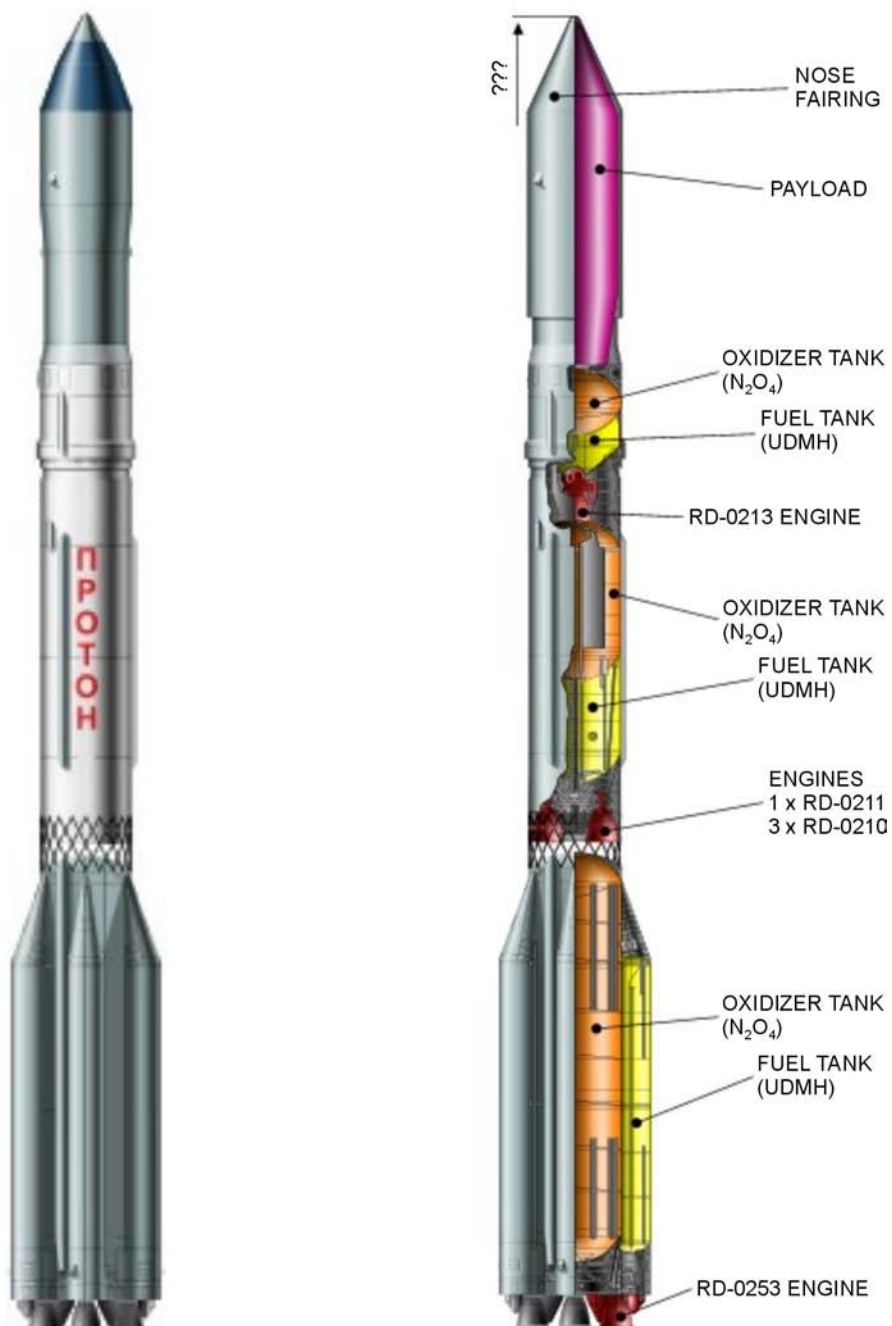

From "Roscosmos Rocket Families" Proton. Retrieved 27 March 2007, from <http://www.roscosmos.ru/RocketsMain.a>

Figure 12S-3 Proton – Federal Space Agency Launch Vehicle

THE ARIANE 5 BOOSTER (SRB) PROPELLANT FUEL IS SOLID.
MAIN ENGINES BURN LIQUID OXYGEN AND LIQUID HYDROGEN.

MAIN DATA: ARIANE 5G
HEIGHT: 46 TO 52 m
DIAMETER: UP TO 5.4 m
LIFTOFF MASS: 746 TONNES

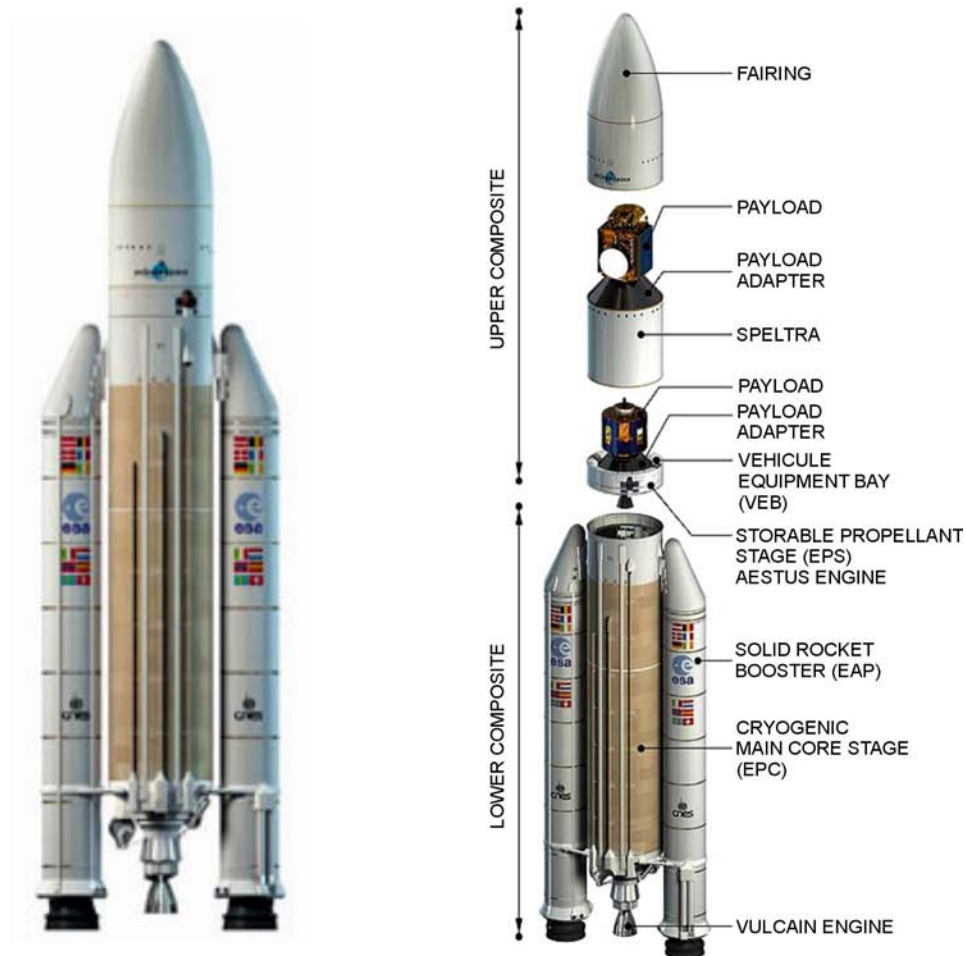

From "European Space Agency" Launch Vehicles. Retrieved 24 March 2007, from http://www.esa.int/SPECIALS/Launchers_Access_to_Space/SEMH3E67ESD_0.html

Figure 12S-4 Ariane 5 – European Space Agency



"China in Space" China's Space Rockets. Retrieved 24 March 2007, from <http://www.spacetoday.org/China/ChinaRockets.html#LongMarchRockets>

Figure 12S-5 Long March (Changzheng) Rockets

THIS PAGE INTENTIONALLY LEFT BLANK

INSTRUCTIONS AND TEMPLATE FOR FOLDING A PAPER HELICOPTER

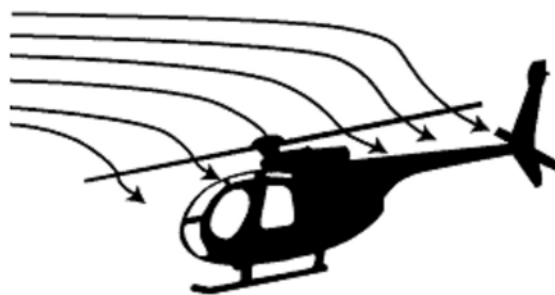

NORMAL POWERED FLIGHT



AUTO-ROTATION FLIGHT

Jeppesen Standard Training Products, A&P Technician General Textbook, Jeppesen Sanderson Training Systems (p. 2-66)

Figure 12T-1 Auto-rotation Flight vs. Normal Powered Flight

MAKE A HELICOPTER

AIM: TO MAKE A TWIRLING HELICOPTER.

YOU WILL NEED: A HELICOPTER SHEET, SCISSORS, COLOURING PENCILS, PAPER CLIPS FOR WEIGHTS

WHAT TO DO:

1. COLOUR THE HELICOPTER SHEET.
2. CUT ALONG THE DOTTED LINES.
3. FOLD CORNERS A AND B TO MEET THE CENTRE LINE
4. FOLD E AND F IN THE OPPOSITE DIRECTIONS.

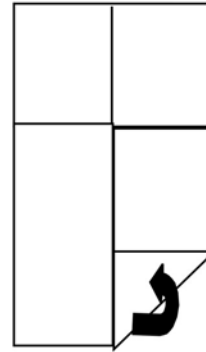
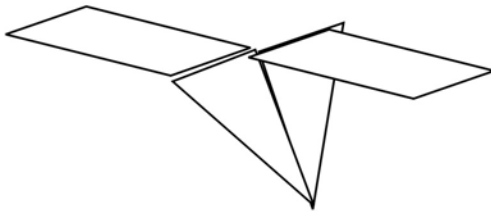

5. TEST YOUR HELICOPTER BY DROPPING IT FROM A HIGH PLACE (E.G. STANDING ON A RAISED PLATFORM).
6. DISCUSS WHAT HAPPENS.

THINGS TO TRY

DOES THE WAY THE FLAPS ARE BENT MAKE A DIFFERENCE TO THE HELICOPTER'S FALL?

ADD EXTRA WEIGHT TO YOUR HELICOPTER. DOES THIS MAKE A DIFFERENCE.

MAKE A NEW HELICOPTER WITH LONGER BLADES. HOW DOES IT WORK?

"Force and Movement" Making a Helicopter. Retrieved 11 October 2006, from http://www.teacherresourcesgalore.com/physics_files/helicopter.doc

Figure 12T-2 Instructions for Paper Helicopter Construction

PAPER HELICOPTER TEMPLATE

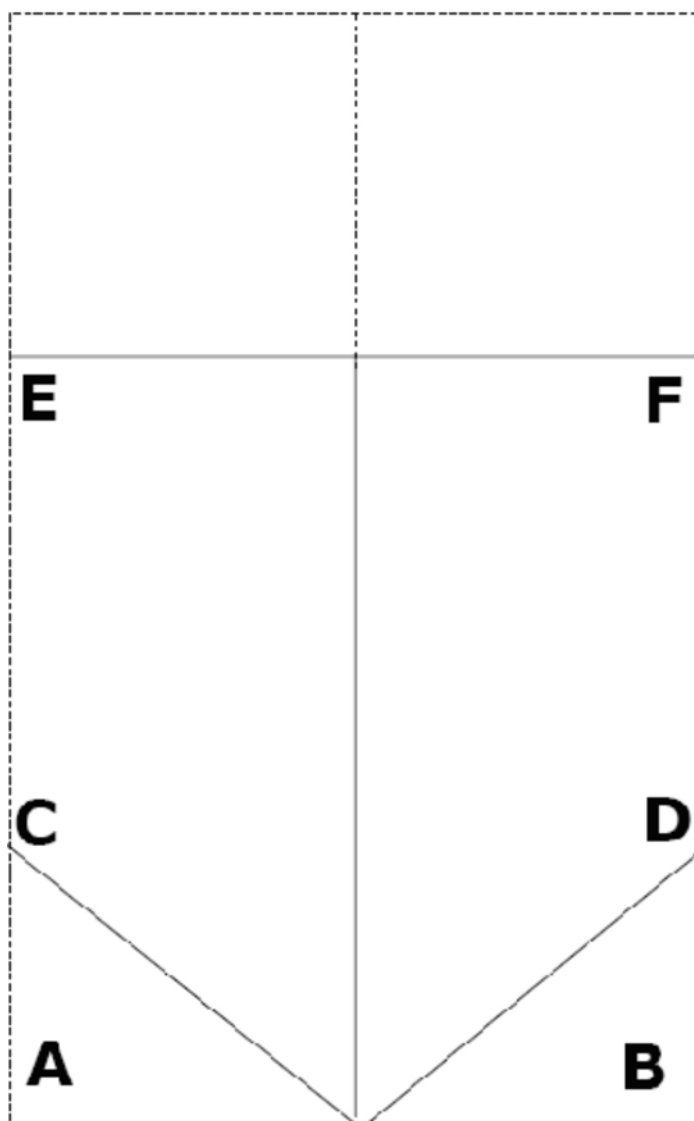

"Force and Movement: Making a Helicopter". Retrieved 11 October 2006, from http://www.teacherresourcesgalore.com/physics_files/helicopter.doc

Figure 12T-3 Template for Paper Helicopter Construction

THIS PAGE INTENTIONALLY LEFT BLANK

CENTRIFUGAL FORCE FLATTENS A ROTOR DISC
CENTRIFUGAL FORCE FLATTENS A ROTOR DISC

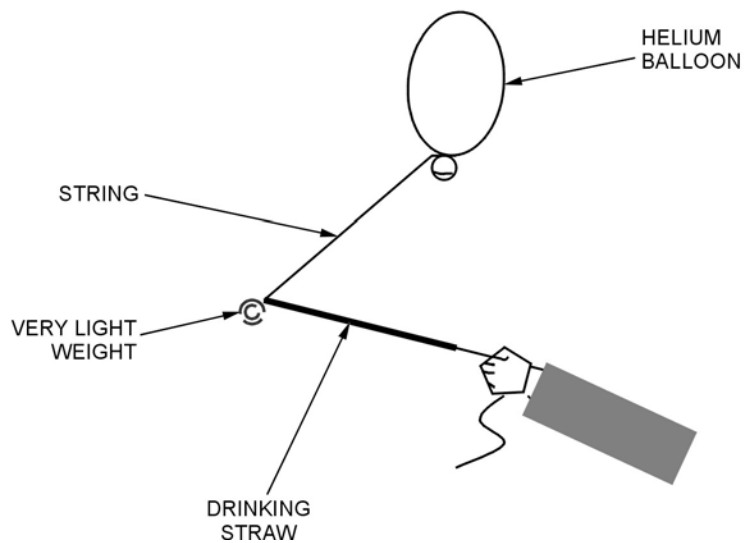

D Cdt's 3, 2007 Ottawa, ON: Department of National Defence

Figure 12U-1 Centrifugal Force Prevents Lift from Coning the Rotor Disc

THIS PAGE INTENTIONALLY LEFT BLANK

TURBOSHAFT ENGINE SCHEMATIC

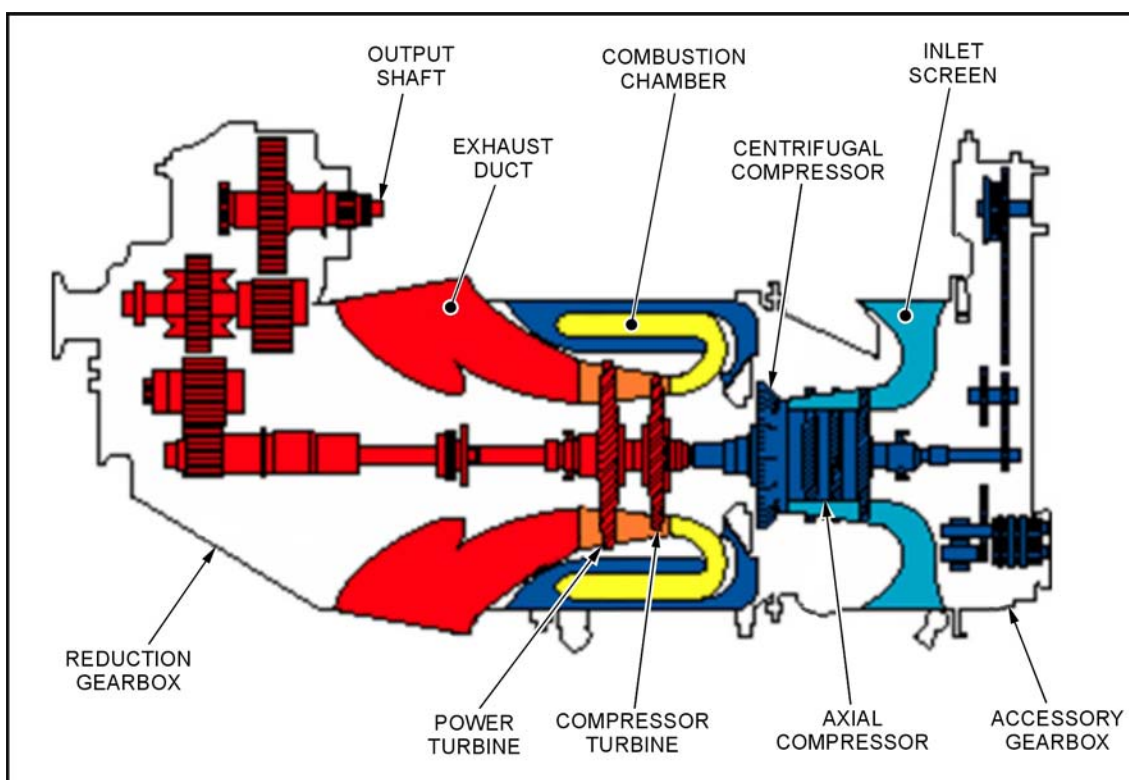

Imagine the Power, Pratt & Whitney Canada. Retrieved 16 March 2007, from http://www.pwc.ca/en/3_0/3_0_3/3_0_3_3_1.asp

Figure 12V-1 Turboshaft Engine Schematic – Separate Turbines

THIS PAGE INTENTIONALLY LEFT BLANK

CF HELICOPTERS



FACTS AND FIGURES - CH-149 CORMORANT

LENGTH:	22.8 m
ROTOR SPAN:	18.5 m
HEIGHT:	6.5 m
WEIGHT:	14 600 kg (MAXIMUM TAKE-OFF)
POWER:	THREE GENERAL ELECTRIC T700-T6A1 TURBOSHAFTS
SPEED:	278 km/h
RANGE:	1018 km

Canadian Forces. Aircraft. (2005). Retrieved 25 March 2007, from http://www.airforce.gc.ca/equip/equip1_e.asp

Figure 12W-1 CH-149 Cormorant



Canadian Forces. Aircraft. (2005). Retrieved 25 March 2007, from http://www.airforce.gc.ca/equip/equip1_e.asp

Figure 12W-2 CH-148 Cyclone

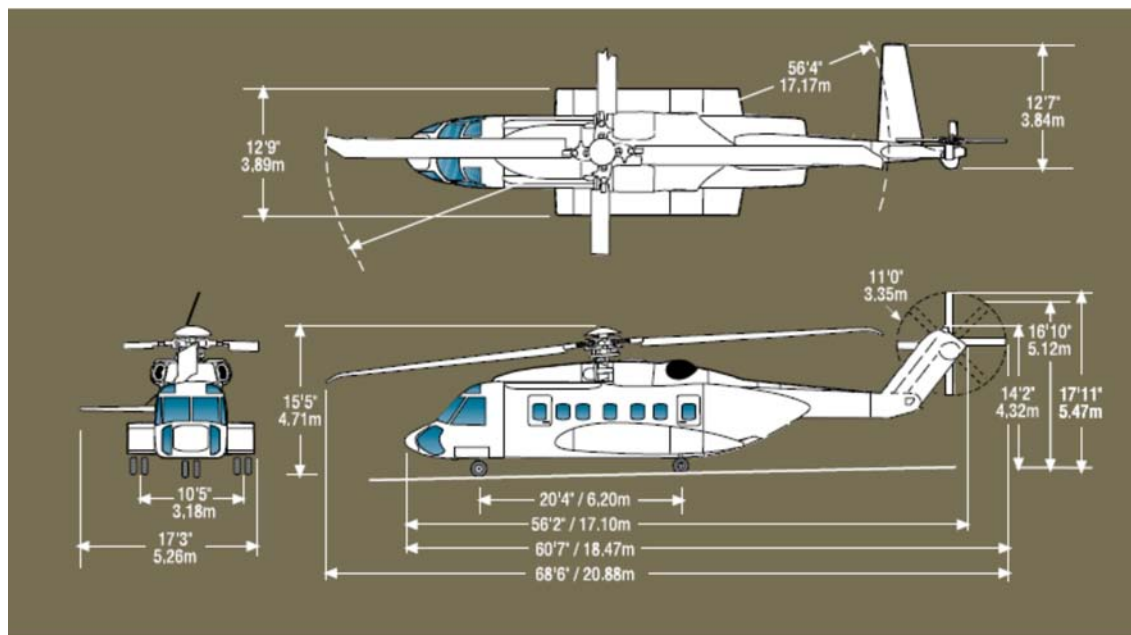

THE S-92 SUPERHAWK FEATURES TWO GENERAL ELECTRIC CT7-8A TURBOSHAFT ENGINES WITH INTEGRAL PARTICLE SEPARATOR AND PNEUMATIC STARTING SYSTEM. IN ADDITION, THE AIRCRAFT INCLUDES A HONEYWELL 36-150 AUXILIARY POWER UNIT FOR ON THE GROUND OR IN THE AIR EMERGENCY POWER.

Sikorsky. S-92 Superhawk Helicopter (2006). Retrieved 25 March 2007, from http://www.sikorsky.com/details/0,,CL11_DIV69_ETI2280,00.html

Figure 12W-3 Sikorsky S-92 Superhawk



FACTS AND FIGURES - CH-146 GRIFFON

LENGTH:	17.1 m
ROTOR SPAN:	14 m
HEIGHT:	4.6 m
WEIGHT:	5355 kg
POWER:	PRATT AND WHITNEY'S PT6T-3D TURBOSHAFT ENGINE
SPEED:	220 km/h
RANGE:	656 km

Canadian Forces. Aircraft. (2005). Retrieved 25 March 2007, from http://www.airforce.gc.ca/equip/equip1_e.asp

Figure 12W-4 CH-146 Griffon



FACTS AND FIGURES - CH-139 JET RANGER

EMPTY WEIGHT:	839 kg
MAX WEIGHT:	1451 kg
HEIGHT:	3.53 m
LENGTH:	(INCLUDING MAIN ROTOR) 11.9 m
SPEED:	130 knots
WIDTH:	(FUSELAGE AND SKID GEAR) 1.92 m
DIAMETER OF MAIN ROTOR:	10.16 m
MAX OPERATING ALTITUDE:	6100 m
ENGINE:	ALLISON MODEL 250-C20B TURBOSHAFT ENGINE

Canadian Forces. Aircraft. (2005). Retrieved 25 March 2007, from http://www.airforce.gc.ca/equip/equip1_e.asp

Figure 12W-5 CH-139 Jet Ranger



FACTS AND FIGURES - CH-124 SEA KING

WEIGHT:	9299 kg
POWER:	TWO 1500 SHP GENERAL ELECTRIC T-58-GE-8F/-100 TURBOSHAFTS
SPEED:	144 km/h MAX SPEED 181 km/h
CEILING:	3048 m
RANGE:	450 km
LOAD:	2268 kg

Canadian Forces. Aircraft. (2005). Retrieved 25 March 2007, from http://www.airforce.gc.ca/equip/equip1_e.asp

Figure 12W-6 CH-124 Sea King

THIS PAGE INTENTIONALLY LEFT BLANK