

CHAPTER 11
PO 231 – EXPLAIN PRINCIPLES OF FLIGHT



ROYAL CANADIAN AIR CADETS
PROFICIENCY LEVEL TWO
INSTRUCTIONAL GUIDE



SECTION 1

EO M231.01 – IDENTIFY THE FOUR FORCES THAT ACT UPON AN AIRCRAFT

Total Time: 60 min

PREPARATION

PRE-LESSON INSTRUCTIONS

Resources needed for the delivery of this lesson are listed in the lesson specification located in A-CR-CCP-802/PG-001, Chapter 4. Specific uses for said resources are identified throughout the Instructional Guide within the TP for which they are required.

Review the lesson content and become familiar with the material prior to delivering the lesson.

Make copies of the handouts located at [Annexes A](#) and [C](#) and slides/handouts of [Figure 11B-1](#).

Create a simple paper glider from the instructions in [Figure 11A-1](#) for demonstration purposes.

PRE-LESSON ASSIGNMENT

N/A.

APPROACH

An interactive lecture was chosen for TP1, TP2 and TP4 to TP7 to introduce the forces that act upon an aircraft and give an overview of them.

An in-class activity was chosen for TP3 as it is an interactive way to provoke thought and stimulate an interest among cadets.

INTRODUCTION

REVIEW

N/A.

OBJECTIVES

By the end of this lesson the cadet shall be expected to identify the four forces that act upon an aircraft.

IMPORTANCE

It is important for cadets to learn and identify the four forces that act upon an aircraft so that they will understand the principles of flight by which an aircraft operates.

Teaching Point 1**Explain That Every Aircraft Has Weight and That a Glider on Tow Gains Energy As It Gains Altitude**

Time: 5 min

Method: Interactive Lecture

Every aircraft has weight, which influences the design and performance of the aircraft.



The weight of an aircraft is the force that acts vertically downward toward the centre of the Earth and is the result of gravity.

The gliders used in the Air Cadet gliding program are towed to their determined altitude by a tow-plane. There are other methods of getting altitude, such as using a winch to get up to speed on the ground.

An aircraft gains energy as it gains altitude. The energy that the glider gains as it is taken to its determined altitude can be spent quickly in a rapid descent to Earth or it can be spent slowly in a long descent.

CONFIRMATION OF TEACHING POINT 1**QUESTIONS**

- Q1. What causes an aircraft to have weight?
- Q2. In what direction does weight and gravity act?
- Q3. How do Air Cadet gliders get to their determined altitude?

ANTICIPATED ANSWERS

- A1. Gravity.
- A2. Vertically, downward toward the centre of the Earth.
- A3. An Air Cadet glider is towed to altitude by a tow-plane.

Teaching Point 2**Explain That a Glider Experiences Drag From the Air as It Returns to the Earth After Being Released**

Time: 5 min

Method: Interactive Lecture

Drag is the resistance that any object experiences as it moves through the air.

Cadets will have experienced the resistance of air on their bicycles or just walking on a windy day.

Effort is put into aircraft design to minimize drag.



Cadets avoid drag when they lower their head and shoulders on a bicycle to gain speed.

The design of an aircraft can minimize drag but cannot avoid it entirely. The faster an aircraft is designed to fly, the more sleek and streamlined its design is likely to be.

A parachute is designed to maximize drag by catching air and using it to slow descent.



An aircraft can use drag to control flight and manoeuvre by pushing on the passing air.

CONFIRMATION OF TEACHING POINT 2

QUESTIONS

- Q1. What is drag?
 Q2. How does a parachute use drag?
 Q3. How does an aircraft use drag?

ANTICIPATED ANSWERS

- A1. Drag is the resistance an object experiences as it moves through the air.
 A2. A parachute is designed to maximize drag by catching air and using it to slow descent.
 A3. An aircraft uses drag to control flight by pushing on the passing air.

Teaching Point 3

Fold and Fly a Simple Paper Glider

Time: 15 min

Method: In-class Activity



During this activity, introduce the cadets to Newton's first law of motion, "an object in motion tends to stay in motion", with regard to aircraft.

ACTIVITY

OBJECTIVE

The objective of this activity is to have the cadets make a simple paper glider and then observe the effects of drag on it as it flies.

RESOURCES

- 8.5 x 11 inch paper, and
- Handouts of instructions for folding a simple paper glider located at [Annex A](#).

ACTIVITY LAYOUT

N/A.

ACTIVITY INSTRUCTIONS

1. Give each cadet a single sheet of 8.5 x 11 inch paper and the instructions for folding, as shown in [Figure 11A-1](#).

2. Each cadet will create a simple paper glider by folding the sheet of paper according to the instructions provided.
3. When directed, the cadets will gently release their gliders and observe them as they descend.

SAFETY

Adequate supervision will ensure that cadets release the simple paper gliders gently.

CONFIRMATION OF TEACHING POINT 3

The cadets' participation in folding and flying a simple paper glider will serve as the confirmation of TP3.

Teaching Point 4

Explain That a Descending Glider Converts the Energy of Raised Weight Into Forward Thrust by Acting Upon the Passing Air

Time: 10 min

Method: Interactive Lecture

As demonstrated in TP3, a glider moves forward as it descends, rather than falling straight down. It accomplishes this by acting on the air in a manner similar to a cadet diving into water.

A glider is always gliding downwards through the air, but by locating atmospheric lift (rising air) to offset the downward motion of the aircraft due to gravity, the pilot can actually gain altitude and fly great distances without needing to use artificial lift again.



Thrust is a force that moves an aircraft forward. A glider spends the energy it has gained and moves forward by trading the speed of descent for forward motion. It gets this control by using its weight to push upon the air below. With its nose lowered, it slides forward over the air below.

CONFIRMATION OF TEACHING POINT 4

QUESTIONS

- Q1. In what direction does a glider always move through the air after being released?
- Q2. What causes the glider to descend?
- Q3. What causes the glider to move forward?

ANTICIPATED ANSWERS

- A1. Downward, toward the centre of the Earth.
- A2. Weight, resulting from gravity.
- A3. Thrust, developed by spending energy, trades the speed of descent for forward motion.

Teaching Point 5**Explain That a Glider's Wings Are Designed To Convert the Energy of the Glider's Descent From Downward Motion To Lift**

Time: 5 min

Method: Interactive Lecture

A glider's wings are designed to project out into the passing air. Glider's wings are usually very large for the size of aircraft because a glider depends on its wings to develop lift without help from an engine or a propeller. As air moves over and under the wing, the air is used by the wing to generate lift.

The purpose of a glider's wings is not to go fast to minimize descent. The object of soaring is to get as much forward distance as possible, while losing as little altitude as possible for each unit of energy that the glider loses in descent. The distance travelled forward compared to the altitude lost is referred to as glide ratio. This should be a very large number such as 30 metres forward for each metre of descent.

The glider's wing is designed to develop lift because lift reduces the rate of descent while allowing forward motion. The lift of the aircraft's wing will counteract the aircraft's weight, to a degree, and this will improve the aircraft's glide ratio. Generally, the larger the wing, the more lift can be developed.

A wing generates lift by acting upon the passing air in a highly sophisticated manner that will be explored in the next lesson.

CONFIRMATION OF TEACHING POINT 5**QUESTIONS**

- Q1. Why does a glider have large wings?
- Q2. What is required for an aircraft wing to develop lift?
- Q3. What is used to overcome the weight of an aircraft?

ANTICIPATED ANSWERS

- A1. A glider depends upon its wings to develop lift without help from an engine.
- A2. Air must move over and under the wing.
- A3. Lift that is created by the aircraft's wing.

Teaching Point 6**Explain That a Powered Aircraft Has Weight and, When in Flight, Also Experiences Drag, Thrust, and Lift**

Time: 10 min

Method: Interactive Lecture

A powered aircraft also experiences weight, drag and lift as does a glider. However, while a glider can gain forward motion only by trading the energy of its descent for thrust, a powered aircraft can generate thrust by running its engine. In this case, thrust is provided to the aircraft via a driven propeller or a high-speed jet exhaust.



Show the cadets a slide (OHP or PPT), or paper handouts, of the four forces that act upon an aircraft shown in [Figure 11B-1](#).

On the other hand, the engine adds weight to the aircraft and both the propeller and engine body add to the drag that the aircraft experiences. A powered aircraft, therefore, will usually not have the high glide ratio of a glider.

A powered aircraft, though, can attain equilibrium, which is something a glider cannot do. Equilibrium is a condition where lift equals weight or thrust equals drag. Pilots often refer to this as flying straight and level.



- If lift is greater than weight, the aircraft will climb higher.
- If weight is greater than lift, the aircraft will descend.
- If thrust is greater than drag, the aircraft's forward speed will increase.
- If drag is greater than thrust, the aircraft's speed will decrease.

CONFIRMATION OF TEACHING POINT 6

QUESTIONS

- Q1. What is aircraft equilibrium?
- Q2. What is necessary for an aircraft to climb higher?
- Q3. What is a downside of having an engine?

ANTICIPATED ANSWERS

- A1. Equilibrium is the condition where lift equals weight or thrust equals drag.
- A2. If lift is greater than weight, the aircraft will climb higher.
- A3. An engine increases the aircraft's weight and often increases its drag.

Teaching Point 7

Explain That Thrust and Drag Allow an Aircraft To Fly by Overcoming Drag and Weight

Time: 5 min

Method: Interactive Lecture

A glider can fly even though it does not produce its own thrust. It can fly even though its weight is greater than its lift. However, in the Earth's gravity, its flight is limited by atmospheric conditions and the pilot's skill. On a day without wind, even the most skilful pilot will soon return to Earth after being released.



With a powered aircraft, descent can be delayed by turning the energy of burning fuel into thrust because thrust can then be turned into lift by the aircraft's wings.

CONFIRMATION OF TEACHING POINT 7

QUESTIONS

- Q1. What are the four forces that act upon an aircraft?
- Q2. What force can overcome weight?
- Q3. What force can overcome both weight and drag?

ANTICIPATED ANSWERS

- A1. Weight, drag, thrust and lift.
- A2. Lift.
- A3. Thrust, because thrust can be converted to lift by the aircraft's wings.

END OF LESSON CONFIRMATION

QUESTIONS

- Q1. How must the four forces that act on an aircraft be arranged to achieve equilibrium?
- Q2. In what direction does weight and gravity act?
- Q3. What is required for an aircraft wing to develop lift?

ANTICIPATED ANSWERS

- A1. Lift must equal weight and thrust must equal drag.
- A2. Vertically, downward toward the centre of the Earth.
- A3. Air must move over and under the wing.



Have each cadet fill in the names of the four forces that act upon an aircraft in the drawing located at [Annex C](#).

CONCLUSION

HOMEWORK/READING/PRACTICE

N/A.

METHOD OF EVALUATION

N/A.

CLOSING STATEMENT

Gliders and powered aircraft are designed for different purposes but they each are subject to the forces of weight, drag, lift and thrust.

INSTRUCTOR NOTES/REMARKS

Advise the cadets that each of the concepts introduced in this lesson will be explored in following lessons.

REFERENCES

- C3-017 (ISBN 1-895569-23-0) Schmidt, N. (1998). *Fabulous Paper Gliders*. New York, NY: Sterling Publishing.

- C3-058 (ISBN 1-4027-3034-9) Schmidt, N. (2005). *Paper Creations Paper Airplanes*. New York, NY. Sterling Publishing.
- C3-090 National Aeronautics and Space Administration (NASA). (2007). *Virtual Skies*. Retrieved 22 February 2007, from <http://virtualskies.arc.nasa.gov/aeronautics/tutorial/intro.html>.
- C3-116 A-CR-CCP-263/PT-001/(ISBN 0-9680390-5-7) MacDonald, A. F. and Pepler, I. L. (2000). *From the Ground Up: Millennium Edition*. Ottawa, ON: Aviation Publishers Co. Limited.



ROYAL CANADIAN AIR CADETS
PROFICIENCY LEVEL TWO
INSTRUCTIONAL GUIDE



SECTION 2

EO M231.02 – DESCRIBE THE PRODUCTION OF LIFT BY AN AIRCRAFT WING

Total Time: 60 min

PREPARATION

PRE-LESSON INSTRUCTIONS

Resources needed for the delivery of this lesson are listed in the lesson specification located in A-CR-CCP-802/PG-001, Chapter 4. Specific uses for said resources are identified throughout the Instructional Guide within the TP for which they are required.

Review the lesson content and become familiar with the material prior to delivering the lesson.

Create presentation slides or handouts of [Figures 11D-1](#), [11D-2](#), [11E-1](#) and [11F-1](#).

PRE-LESSON ASSIGNMENT

N/A.

APPROACH

An interactive lecture was chosen for TP1, TP2 and TP4 to introduce the production of lift and give an overview of it.

An in-class activity was chosen for TP3 and TP5 as it is an interactive way to provoke thought and stimulate interest among cadets.

INTRODUCTION

REVIEW

Review for this lesson is from EO M231.01 (The Four Forces That Act Upon an Aircraft). Review the four forces that act upon an aircraft and the condition of equilibrium.

OBJECTIVES

By the end of this lesson the cadet shall be expected to describe the production of lift by an aircraft wing.

IMPORTANCE

It is important for cadets to learn about the production of lift by an aircraft wing so that they can develop an understanding of subsequent and related principles of flight.

Teaching Point 1**Explain That Air Acts Like a Fluid Insofar As It Has Inertia, Speed, and Pressure**

Time: 5 min

Method: Interactive Lecture

Air follows Newton's laws of motion:

- Newton's first law predicts that air, being a gaseous fluid, tends to remain in motion when it is moving.
- Newton's second law of motion requires that a force must be applied to change the air's motion.
- Newton's third law of motion allows the aircraft wing, by applying a force that changes the motion of air, to develop lift through an opposite and equal reaction.



The fact that air has mass is very important in aviation. Even though air's mass is less than the mass of most solids, its mass is still great enough to allow an aircraft to fly and to allow the aircraft to control its own flight.

CONFIRMATION OF TEACHING POINT 1

QUESTIONS

- Q1. How does air follow Newton's first law of motion?
- Q2. How does air follow Newton's second law of motion?
- Q3. How does air follow Newton's third law of motion?

ANTICIPATED ANSWERS

- A1. When in motion, air tends to remain in motion.
- A2. When in motion, a force must be applied to change air's motion.
- A3. When air's motion is changed, an equal and opposite reaction results.

Teaching Point 2**Introduce Bernoulli's Principle, Which States That a Liquid's Pressure Drops When Its Speed Increases (Venturi Effect)**

Time: 10 min

Method: Interactive Lecture

To develop the equal and opposite reaction described by Newton's third law of motion, the wing is given a shape that takes advantage of Bernoulli's Principle to make the air change direction. Air behaves like a fluid since it has pressure and speed. As airspeed increases, its pressure drops. A wing uses Bernoulli's Principle to deflect air, which causes an equal and opposite reaction.



Show the cadets a slide or handout of definitions of Bernoulli's principle shown in [Figure 11D-1](#).



One part of Bernoulli's Principle that is very useful to remember is that if air speed increases, pressure decreases and if speed decreases, pressure increases. This is an inverse relationship between airspeed and air pressure. This part of Bernoulli's Principle is often referred to as the venturi principle. The shape of the wing is carefully calculated to decrease pressure above while increasing pressure below.

CONFIRMATION OF TEACHING POINT 2

QUESTIONS

- Q1. What relationship exists between air speed and air pressure?
- Q2. What is the wing's connection between Newton's third law and Bernoulli's Principle?
- Q3. What is a wing's shape calculated to do?

ANTICIPATED ANSWERS

- A1. An inverse relationship: as speed increases, pressure drops and as speed drops, pressure increases.
- A2. A wing uses Bernoulli's Principle to deflect air, which causes an equal and opposite reaction.
- A3. A wing's shape is calculated to decrease pressure above while increasing pressure below.

Teaching Point 3

Have the Cadets Explore Bernoulli's Principle

Time: 10 min

Method: In-class Activity

The pressure of moving air can be examined by blowing gently over a small piece of curved paper. The air does not push the paper down as might be intuitively assumed. Instead, the paper behind the curve rises toward the moving air. This happens because the air pressure drops over the paper due to the air's increased speed – this would seem to match the description of speed/pressure relationship. The curvature in the paper enhances the effect of the lowered air pressure.

A similar effect can be observed when air moves past any object that is light enough to be affected by the drop in air pressure associated with movement. A balloon is light enough to show this effect clearly.



Show the cadets a slide or handout of [Figure 11D-2](#). Have one half of the class duplicate this paper airfoil activity at their desks while the other half of the class performs the following activity with balloons.

Then, have the groups switch and repeat.

ACTIVITY

Time: 5 min

OBJECTIVE

The objective of this activity is to have the cadets reduce the air pressure over a sheet of paper and observe the results.

RESOURCES

- Paper 8 1/2 x 11, and
- Pencil.

ACTIVITY LAYOUT

N/A.

ACTIVITY INSTRUCTIONS

1. Tear a sheet of paper 8 1/2 x 11 vertically, into two pieces.
2. Curve one end of the sheet gently over a pencil as shown in [Figure 11D-2](#).
3. Blow gently over the paper as shown in [Figure 11D-2](#).
4. Observe that the paper rises into the moving air.

SAFETY

N/A.

ACTIVITY

Time: 5 min

OBJECTIVE

The objective of this activity is to have the cadets see the action of air pressure.

RESOURCES

- Balloons, and
- String.

ACTIVITY LAYOUT

Hang two long well-inflated balloons at the front of the classroom so they are at shoulder height, hanging 15 centimetres apart. This must be in a draft-free area. The balloons must hang very still so that the effect is clearly visible.

Alternatively, for more visual effect, this can also be done with helium-filled balloons with strings weighted to the floor, floating a metre high.

ACTIVITY INSTRUCTIONS

Have each cadet approach the balloons slowly, one at a time, and blow gently between them. The cadet will observe that the balloons move toward each other, not apart.

If a single balloon is used, the cadet can simply blow beside the balloon and the balloon will move toward the moving air.

SAFETY

N/A.

CONFIRMATION OF TEACHING POINT 3

QUESTIONS

- Q1. Why does the paper airfoil rise when a cadet blows over it?
- Q2. Why do balloons move toward moving air?
- Q3. Why was the paper deliberately curved before blowing over it?

ANTICIPATED ANSWERS

- A1. Air pressure over the paper drops as the air moves, so the still air below the paper pushes it up.
- A2. Moving air pressure is lower, so still air pushes the balloon into the moving air.
- A3. The curvature in the paper enhances the effect of the lowered air pressure.

Teaching Point 4**Introduce Angle of Attack**

Time: 5 min

Method: Interactive Lecture

An aircraft wing is an airfoil because of its cross-sectional shape. The top surface is curved outward (convex curvature). Therefore, the air flowing over the top has further to go, over the curve, and so it must move faster which, as we know, will result in lower pressure. This happens above the wing.

Below the wing, the air is deliberately slowed to increase its pressure. This is done by curving the surface slightly inward (concave curvature) and by sloping the wing so that it is slightly higher at the front (leading edge) than it is at the back (trailing edge). This angle of the wing's under-surface, which encounters the moving air, is called the wing's angle of attack.



Use a model aircraft to demonstrate to the cadets that the wing's angle of attack increases when the aircraft's nose is raised during flight.



The greater the wing's angle of attack, the more air the under-surface of the wing will encounter, thereby generating more lift. This is a direct relationship between angle of attack and lift.

Increasing the wing's speed will also cause it to encounter more air, thereby generating more lift. This is also a direct relationship between speed and lift.

There is a limit to the amount of lift that can be produced by merely increasing the angle of attack. Long before the wing becomes vertical, it stops generating lift above and this often happens abruptly. The wing "stalls" and stops generating lift when this happens.

CONFIRMATION OF TEACHING POINT 4

QUESTIONS

- Q1. Which surface of an aircraft wing is curved outward (convex)?

Q2. What shape is often given to the underside of an aircraft wing?

Q3. What happens to air pressure under a wing as angle of attack increases?

ANTICIPATED ANSWERS

A1. The top surface of a wing is curved outward.

A2. A slight inward, or concave, curve is often given to an aircraft wing.

A3. The pressure increases as angle of attack increases.

Teaching Point 5

Have Each Cadet Create and Fly an Airfoil

Time: 25 min

Method: In-class Activity

ACTIVITY

OBJECTIVE

The objective of this activity is to have the cadets see an airfoil lift itself in a stream of moving air.

RESOURCES

- Index cards,
- Tape,
- Hole punch or sharp pencil,
- Scissors,
- Plastic drinking straw,
- Bamboo skewers or large straightened paper clips,
- Base that the skewers can stick into (Styrofoam or corrugated cardboard), and
- Hairdryer or fan.

ACTIVITY LAYOUT

This activity may take place at the cadets' desks/tables.

ACTIVITY INSTRUCTIONS

Give each cadet an index card to fold into an airfoil shape with mounting holes for the launching skewers. The cadets will:

1. Fold the card in half. Tape the top of the card down to the bottom half of the card so that about 6 mm (1/4 inch) of the bottom shows, leaving the top in a curve and the bottom flat. This will produce a cross-section airfoil shape.
2. Use the hole punch (or a sharp pencil) to put two sets of holes in the thickest part of the airfoil.
3. Cut the straw so you get two pieces 5 cm (2 inches) long. Fit these mini-straws through the holes in the airfoil.

4. Set the airfoil on the base and slip a skewer or unbent paper clip through each of the mini-straws and into the base.
5. Use the hairdryer or fan to move air over the airfoil to create lift. Try it both ways—with the flat side of the airfoil on the bottom and with the flat side on the top. Note which position the airfoil is in when it climbs best.

SAFETY

N/A.

CONFIRMATION OF TEACHING POINT 5

The cadet's participation in creating and flying an airfoil will serve as the confirmation of TP5.

END OF LESSON CONFIRMATION**QUESTIONS**

- Q1. How does the top surface of a wing generate lift?
- Q2. How does the under-surface of a wing generate lift?
- Q3. What determines how much lift is produced by a wing at a given speed?

ANTICIPATED ANSWERS

- A1. The top surface of a wing generates lift by lowering air pressure over the wing.
 - A2. The under-surface of a wing generates lift by raising air pressure under the wing.
 - A3. The angle of attack will determine how much lift is produced at a given speed.
-

CONCLUSION**HOMEWORK/READING/PRACTICE**

N/A.

METHOD OF EVALUATION

N/A.

CLOSING STATEMENT

There are other methods of producing lift, such as rocketry, but airfoils are by far the most common, not just because of their elegance, but because they are best suited to prolonged horizontal flight.

INSTRUCTOR NOTES/REMARKS

N/A.

REFERENCES

- C3-017 (ISBN 1-895569-23-0) Schmidt, N. (1998). *Fabulous Paper Gliders*. New York, NY: Sterling Publishing.

- C3-058 (ISBN 1-4027-3034-9) Schmidt, N. (2005). *Paper Creations Paper Airplanes*. New York, NY: Sterling Publishing.
- C3-091 (ISBN 1-55652-477-3) Carson, M. K. (2003). *The Wright Brothers for Kids: How They Invented the Airplane*. Chicago, IL: Chicago Review Press.
- C3-116 A-CR-CCP-263/PT-001/(ISBN 0-9680390-5-7) MacDonald, A. F. and Pepler, I. L. (2000). *From the Ground Up: Millennium Edition*. Ottawa, ON: Aviation Publishers Co. Limited.



ROYAL CANADIAN AIR CADETS
PROFICIENCY LEVEL TWO
INSTRUCTIONAL GUIDE



SECTION 3

EO M231.03 – DESCRIBE THE TYPES OF DRAG THAT ACT UPON AN AIRCRAFT

Total Time:

60 min

PREPARATION

PRE-LESSON INSTRUCTIONS

Resources needed for the delivery of this lesson are listed in the lesson specification located in A-CR-CCP-802/PG-001, Chapter 4. Specific uses for said resources are identified throughout the Instructional Guide within the TP for which they are required.

Review the lesson content and become familiar with the material prior to delivering the lesson.

Create presentation slides or handouts of all figures located at [Annexes G to J](#).

PRE-LESSON ASSIGNMENT

N/A.

APPROACH

An interactive lecture was chosen for TP1, TP2 and TP4 to introduce the subject of drag and give an overview of it.

An in-class activity was chosen for TP3 and TP5 as it is an interactive way to provoke thought and stimulate an interest among cadets.

INTRODUCTION

REVIEW

Review EO M231.01 (The Four Forces That Act Upon an Aircraft), to include:

- weight,
- drag,
- thrust, and
- lift.

OBJECTIVES

By the end of this lesson the cadet shall be expected to identify and discuss the types of drag that act upon an aircraft.

IMPORTANCE

It is important for cadets to know the types of drag that act upon an aircraft so that they will understand subsequent and related principles of flight.

Teaching Point 1

Introduce Drag as a Useful Force and Explain the Two Types of Drag

Time: 5 min

Method: Interactive Lecture

Drag is the force that opposes the forward motion of an aircraft. The two main types of drag are parasite drag and induced drag.



Show the cadets a slide or distribute handouts of drag definitions located at [Annex G](#).

Parasite drag is caused by those parts of the aircraft that do not generate lift such as the fuselage, landing gear, struts, antennas, wing tip fuel tanks, etc. Any drag caused by openings, such as those in the cowling and those between the wing and the ailerons and flaps, add to parasite drag.

Induced drag is produced by those parts of an aircraft that are active in producing lift, such as the wings. Induced drag is the result of the wing and is therefore a part of lift and can never be eliminated.

It is true that drag does limit an aircraft's performance. However, drag also allows the pilot to control flight because an aircraft turns by increasing the drag in certain areas using control surfaces that push on the passing air. Without drag, an aircraft could not fly in a controlled manner.

CONFIRMATION OF TEACHING POINT 1

QUESTIONS

- Q1. What is drag?
- Q2. What causes parasite drag?
- Q3. What produces induced drag?

ANTICIPATED ANSWERS

- A1. Drag is the force that opposes the forward motion of an aircraft.
- A2. Parasite drag is caused by those parts of the aircraft that do not generate lift.
- A3. Induced drag is produced by those parts of an aircraft that are active in producing lift.

Teaching Point 2**Define the Components of Parasite Drag**

Time: 5 min

Method: Interactive Lecture



Show the cadets a slide or distribute handouts of parasite drag definitions located at [Annex H](#).

Parasite drag is broken down into two components; form drag and skin friction:

- Form drag refers to the drag created by the form or shape of a body as it resists motion through the air.
- Skin friction refers to the tendency of air flowing over a body to cling to its surface.



Using a model aircraft with wing struts and a fixed landing gear, show the cadets parts of the aircraft that contribute to parasite drag.



Although parasite drag can never be eliminated, it can be reduced. One method is to remove parts of the aircraft that cause it. For this reason, retractable landing gears have been developed. Another method is to streamline those parts that cannot be eliminated. Skin friction can be reduced substantially by the removal of dust, dirt, mud or ice that has collected on the aircraft.

CONFIRMATION OF TEACHING POINT 2

QUESTIONS

- Q1. Identify and describe the two types of parasite drag.
- Q2. How do aircraft designers reduce form drag?
- Q3. How do aircraft operators reduce skin friction?

ANTICIPATED ANSWERS

- A1. Form drag refers to the drag created by the form or shape of a body as it resists motion through the air. Skin friction refers to the tendency of air flowing over a body to cling to its surface.
- A2. Aircraft designers reduce form drag by removing or streamlining those parts of the aircraft that cause it.
- A3. Aircraft operators can reduce skin friction by removing dust, dirt, mud or ice that has collected on the aircraft.

Teaching Point 3**Demonstrate Form Drag**

Time: 15 min

Method: In-class Activity

ACTIVITY**OBJECTIVE**

The objective of this activity is to have the cadets fold and fly a device with greater drag on one side than the other and then to see that it always falls in the direction with the least drag.

RESOURCES

- Square paper 70 mm x 70 mm (square self-adhesive notes are ideal), and
- Tape.

ACTIVITY LAYOUT

N/A.

ACTIVITY INSTRUCTIONS

Have the cadets fold their paper squares diagonally on both diagonals from point to point and then in half vertically. The paper square can now be put into the shape of a three-sided pyramid by tucking in only the bottom area along the vertical fold. The top area of the vertical fold must be smoothed flat to remove the fold. This will produce a hollow three-sided pyramid of paper which, when dropped in any orientation, will orient itself during the fall to always land on its point.

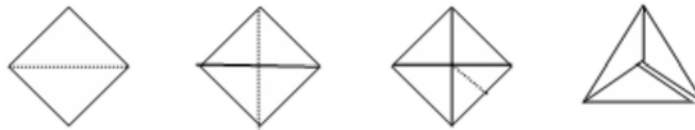

D Cdts 3, 2007 Ottawa, ON: Department of National Defence.

Figure 11-3-1 Folding a Hollow Pyramid

Have the cadets try dropping their paper pyramids in all orientations and have them observe how the pyramids land on their points in all cases.

SAFETY

N/A.

CONFIRMATION OF TEACHING POINT 3

The cadets' participation in this activity will serve as confirmation of this TP.

Teaching Point 4**Explain Induced Drag**

Time: 10 min

Method: Interactive Lecture



Show the cadets a slide or distribute handouts of the induced drag definitions located at [Annex I](#).

Induced drag is another force that opposes the forward motion of the aircraft, but it is produced by those parts of an aircraft that are active in producing lift. Induced drag results from the wing and is therefore a part of lift that can never be eliminated.



Induced drag increases as the angle of attack increases and decreases as the angle of attack decreases.

Induced drag can only be reduced during the initial designing of the aircraft. The phenomenon known as wing tip vortices seen in [Figure 11J-1](#) is testimony to the existence of induced drag.



Show the cadets a slide or distribute handouts of the aircraft shown in [Figure 11J-1](#).
Point out the wing tip vortices.

Aircraft are often fixed with upwardly swept wing tip “winglets” to reduce wing tip vortices and their associated induced drag as shown in [Figure 11J-2](#).

The various forms of drag change with different flying conditions and, in general, they increase with speed. As well, when the pilot uses control surfaces, they produce both form drag and induced drag.



Cadets interested in further reading can read the explanation of wing tip vortices in A-CR-CCP-263/PT-001, *From the Ground Up: Millennium Edition*, in the section on induced drag.

CONFIRMATION OF TEACHING POINT 4**QUESTIONS**

- Q1. What is the relationship between angle of attack and induced drag?
- Q2. When is the optimum time to minimize induced drag?
- Q3. What is the relationship between drag and air speed?

ANTICIPATED ANSWERS

- A1. Induced drag increases as the angle of attack increases and induced drag decreases as the angle of attack decreases.

A2. During the design of the aircraft.

A3. Drag tends to increase with increasing speed.

Teaching Point 5**Demonstrate Induced Drag**

Time: 20 min

Method: In-class Activity

ACTIVITY

OBJECTIVE

The objective of this activity is to have the cadets experience the sensation of induced drag.

RESOURCES

- Bristol board,
- Tape, and
- Fan.

ACTIVITY LAYOUT

N/A.

ACTIVITY INSTRUCTIONS

Create a wing-like surface by taping together two pieces of Bristol board 50 cm square. Tape only three sides so that the cadet can put one hand inside this “wing”.

Turn on the fan. Have each cadet place a hand in the wing below the fan and slowly raise the wing toward the moving air, using only a very slight angle of attack. In addition to the feeling of lift into the moving air, the cadet will also sense the backward pull of induced drag just before the stronger push of form drag is experienced.

SAFETY

N/A.

CONFIRMATION OF TEACHING POINT 5

The cadets' participation in the activity will serve as the confirmation of this TP.

END OF LESSON CONFIRMATION

QUESTIONS

- Q1. What are the main types of drag?
- Q2. What causes parasite drag?
- Q3. What is the relationship between angle of attack and induced drag?

ANTICIPATED ANSWERS

A1. The main types of drag are parasite drag and induced drag.

- A2. Parasite drag is caused by those parts of the aircraft that do not generate lift.
- A3. Induced drag increases as the angle of attack increases and induced drag decreases as the angle of attack decreases.

CONCLUSION

HOMEWORK/READING/PRACTICE

N/A.

METHOD OF EVALUATION

N/A.

CLOSING STATEMENT

Understanding drag is important because drag affects both the design and performance of aircraft.

INSTRUCTOR NOTES/REMARKS

N/A.

REFERENCES

- C3-017 (ISBN 1-895569-23-0) Schmidt, N. (1998). *Fabulous Paper Gliders*. New York, NY: Sterling Publishing.
- C3-058 (ISBN 1-4027-3034-9) Schmidt, N. (2005). *Paper Creations Paper Airplanes*. New York, NY: Sterling Publishing.
- C3-092 (ISBN 0-7460-0978-X) Edom, H., Butterfield, M., Heddle, R. and Unwin, M. (1992). *The Usborne Book of Science Activities: Volume Two*. Tulsa OK: EDC Publishing.
- C3-116 A-CR-CCP-263/PT-001/(ISBN 0-9680390-5-7) MacDonald, A. F. and Peppler, I. L. (2000). *From the Ground Up: Millennium Edition*. Ottawa, ON: Aviation Publishers Co. Limited.

THIS PAGE INTENTIONALLY LEFT BLANK



ROYAL CANADIAN AIR CADETS
PROFICIENCY LEVEL TWO
INSTRUCTIONAL GUIDE



SECTION 4

EO M231.04 – DESCRIBE THE AXIAL MOVEMENTS OF AN AIRCRAFT

Total Time: 30 min

PREPARATION

PRE-LESSON INSTRUCTIONS

Resources needed for the delivery of this lesson are listed in the lesson specification located in A-CR-CCP-802/PG-001, Chapter 4. Specific uses for said resources are identified throughout the Instructional Guide within the TP for which they are required.

Review the lesson content and become familiar with the material prior to delivering the lesson.

Create presentation slides of [Figure 11K-1](#).

Copy the handouts located at [Annexes K](#) and [L](#) for each cadet.

Obtain a model of a light fixed-wing aircraft with wing struts, fixed gear and control surface detail.

PRE-LESSON ASSIGNMENT

N/A.

APPROACH

An interactive lecture was chosen for TP1 and TP2 to introduce the subject of axial movement and give an overview of it.

A group discussion was chosen for TP3 and TP4 as it allows the cadets to interact with their peers and share their knowledge, experiences, opinions, and feelings about axial aircraft movement.

INTRODUCTION

REVIEW

Review EO M231.01 (The Four Forces That Act Upon an Aircraft), to include:

- weight,
- drag,
- thrust,
- lift, and
- the state of equilibrium.

OBJECTIVES

By the end of this lesson the cadet shall be expected to identify the three axes of an aircraft and describe an aircraft's movement about them.

IMPORTANCE

It is important for cadets to learn about aircraft axes and axial movement so that they can understand subsequent and related principles of flight.

Teaching Point 1

Identify the Three Axes of Aircraft Movement

Time: 5 min

Method: Interactive Lecture

Aircraft operate in a three-dimensional space so there are three corresponding ways they can turn. Each of the three possibilities has an associated axis of motion:

- the longitudinal axis,
- the lateral axis, and
- the vertical axis.



Show the cadets a slide or distribute handouts of aircraft axes in [Figure 11K-1](#).

When an aircraft is airborne, it can move in almost any direction. All movement of the aircraft takes place around the centre of gravity. This is the aircraft's balance point, or point through which all weight acts downwards.



The centre of gravity is the point where the three axes intersect.

To clarify the ways that aircraft can move in flight, the aircraft is said to move around an axis. This is an imaginary line running through the centre of gravity of the aircraft and around which the aircraft rotates.

There are three such axes and the aircraft may rotate around one, two or all three axes at the same time. They are the longitudinal axis, the lateral axis, and the vertical axis:

- The longitudinal axis runs lengthwise through the fuselage from the nose to the tail and passes through the centre of gravity.
- The lateral axis runs from wingtip to wingtip through the centre of gravity.
- The vertical axis runs vertically through the centre of gravity. It is situated at right angles to the other axes.

CONFIRMATION OF TEACHING POINT 1

QUESTIONS

- Q1. Why does an aircraft have exactly three axes of motion?
- Q2. Where is an aircraft's centre of gravity located?

Q3. What are the three axes of an aircraft called?

ANTICIPATED ANSWERS

A1. An aircraft operates in a three-dimensional space and needs an axis for each dimension.

A2. At the intersection of the three axes of motion.

A3. The three axes of an aircraft are the longitudinal axis, the lateral axis and the vertical axis.

Teaching Point 2

Describe the Three Axial Movements That Aircraft Make

Time: 10 min

Method: Interactive Lecture



Using a model aircraft, describe the three movements that aircraft make around their three axes, to include:

- roll about the longitudinal axis;
- pitch about the lateral axis; and
- yaw about the vertical axis.

Rolling. Movement of an aircraft about the longitudinal axis is called roll.

Pitching. Movement of an aircraft about the lateral axis is called pitch.

Yawing. Movement of an aircraft about the vertical axis is called yaw.



Show the cadets a slide or distribute handouts of aircraft axes in [Figure 11K-1](#), bringing their attention to the motions of roll, yaw and pitch.

CONFIRMATION OF TEACHING POINT 2

QUESTIONS

Q1. What is roll?

Q2. What is pitch?

Q3. What is yaw?

ANTICIPATED ANSWERS

A1. Roll is the movement of an aircraft about its longitudinal axis.

A2. Pitch is the movement of an aircraft about its lateral axis.

A3. Yaw is the movement of an aircraft about its vertical axis.

Teaching Point 3**Discuss Simultaneous Axial Movement of an Aircraft**

Time: 5 min

Method: Group Discussion

BACKGROUND KNOWLEDGE

The point of the group discussion is to draw the following information from the group using the tips for answering/facilitating discussion and the suggested questions provided.

It is possible for an aircraft to move in only one axis at a time but it is not necessary. Although an aircraft can climb or descend using only pitch around the lateral axis, movement around all three axes simultaneously is necessary for efficient flight.



Show the cadets a slide or distribute handouts of aircraft axes in [Figure 11K-1](#).

When riding a bicycle around a high-speed turn, it is necessary to not only yaw to make the turn, but efficient cycling requires the cyclist to lean into the turn, (or roll) slightly as the turn is made. A turn without leaning would be very slow and inefficient and would be the mark of a beginner cyclist.

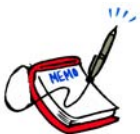

Using a model aircraft, demonstrate that a turn with only yaw requires that the aircraft side-slip.

Similarly, an aircraft normally makes a “bank” manoeuvre in a level turn, involving movement about the longitudinal as well as the vertical axis. A climbing or descending turn requires that movement around the lateral axis be included as well.

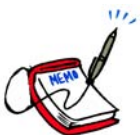

Demonstrate a climbing turn with a model aircraft.

GROUP DISCUSSION



TIPS FOR ANSWERING/FACILITATING DISCUSSION

- Establish ground rules for discussion, e.g. everyone should listen respectfully; don't interrupt; only one person speaks at a time; no one's ideas should be made fun of; you can disagree with ideas but not with the person; try to understand others as much as you hope they understand you; etc.
- Sit the group in a circle, making sure all cadets can be seen by everyone else.
- Ask questions that will provoke thought; in other words avoid questions with yes or no answers.
- Manage time by ensuring the cadets stay on topic.
- Listen and respond in a way that indicates you have heard and understood the cadet. This can be done by paraphrasing their ideas.
- Give the cadets time to respond to your questions.
- Ensure every cadet has an opportunity to participate. One option is to go around the group and have each cadet answer the question with a short answer. Cadets must also have the option to pass if they wish.
- Additional questions should be prepared ahead of time.

SUGGESTED QUESTIONS

- Q1. Can an aircraft turn around one axis at a time? Why?
- Q2. What axial movements are normally used in a level turn? Why?
- Q3. What manoeuvre requires movement around all three axis simultaneously? Why?
- Q4. How does an aircraft bank?



Other questions and answers will develop throughout the group discussion. The group discussion should not be limited to only those suggested.



Reinforce those answers given and comments made during the group discussion, ensuring the teaching point has been covered.

CONFIRMATION OF TEACHING POINT 3

The cadets' participation in the group discussion will serve as confirmation of the TP.

Teaching Point 4**Brainstorming How Aircraft Flight Might Be Controlled**

Time: 5 min

Method: Group Discussion

BACKGROUND KNOWLEDGE

The point of the group discussion is to draw the following information from the group using the tips for answering/facilitating discussion and the suggested questions provided.

Have the cadets brainstorm various methods of controlling yaw, roll and pitch. Encourage them to “think outside the box”. Tell them that the usual way of accomplishing control is only one of many that have been tried and used successfully over the years (Hint: a space shuttle and a helicopter both use different methods at different times).

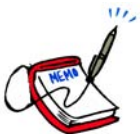
GROUP DISCUSSION**TIPS FOR ANSWERING/FACILITATING DISCUSSION**

- Establish ground rules for discussion, e.g. everyone should listen respectfully; don't interrupt; only one person speaks at a time; no one's ideas should be made fun of; you can disagree with ideas but not with the person; try to understand others as much as you hope they understand you; etc.
- Sit the group in a circle, making sure all cadets can be seen by everyone else.
- Ask questions that will provoke thought; in other words avoid questions with yes or no answers.
- Manage time by ensuring the cadets stay on topic.
- Listen and respond in a way that indicates you have heard and understood the cadet. This can be done by paraphrasing their ideas.
- Give the cadets time to respond to your questions.
- Ensure every cadet has an opportunity to participate. One option is to go around the group and have each cadet answer the question with a short answer. Cadets must also have the option to pass if they wish.
- Additional questions should be prepared ahead of time.

QUESTIONS

- Q1. How might the pilot of an aircraft control the aircraft's movements during flight?
- Q2. How do you think yaw might be controlled?
- Q3. How do you think pitch might be controlled?
- Q4. How do you think roll might be controlled?



Other questions and answers will develop throughout the group discussion. The group discussion should not be limited to only those suggested.



Reinforce those answers given and comments made during the group discussion, ensuring the teaching point has been covered.

CONFIRMATION OF TEACHING POINT 4

The cadets' participation in the group discussion will serve as confirmation of the TP.

END OF LESSON CONFIRMATION

SUGGESTED QUESTIONS

- Q1. Name one axial aircraft movement and its associated axis.
- Q2. Name a second axial aircraft movement and its associated axis.
- Q3. Name a third axial aircraft movement and its associated axis.

ANTICIPATED ANSWERS

- A1. Roll is the axial movement around an aircraft's longitudinal axis.
- A2. Pitch is the axial movement around an aircraft's lateral axis.
- A3. Yaw is the axial movement around an aircraft's vertical axis.

CONCLUSION

HOMEWORK/READING/PRACTICE

N/A.

METHOD OF EVALUATION

N/A.

CLOSING STATEMENT

Movement through a three-dimensional space requires three axes of movement. The names of the axes and the names of the movements are borrowed from the sea, where ships have pitched, yawed and rolled for thousands of years.

INSTRUCTOR NOTES/REMARKS

N/A.

REFERENCES

- C3-017 (ISBN 1-895569-23-0) Schmidt, N. (1998). *Fabulous Paper Gliders*. New York, NY: Sterling Publishing.
- C3-116 A-CR-CCP-263/PT-001/(ISBN 0-9680390-5-7) MacDonald, A. F. and Peppler, I. L. (2000). *From the Ground Up: Millennium Edition*. Ottawa, ON: Aviation Publishers Co. Limited.



ROYAL CANADIAN AIR CADETS
PROFICIENCY LEVEL TWO
INSTRUCTIONAL GUIDE



SECTION 5

EO M231.05 – DESCRIBE AIRCRAFT CONTROL SURFACES

Total Time: 60 min

PREPARATION

PRE-LESSON INSTRUCTIONS

Resources needed for the delivery of this lesson are listed in the lesson specification located in A-CR-CCP-802/PG-001, Chapter 4. Specific uses for said resources are identified throughout the Instructional Guide within the TP for which they are required.

Review the lesson content and become familiar with the material prior to delivering the lesson.

Create presentation slides or handouts of [Figures 11M-1, 11N-1, 11O-1](#) and [11P-1](#).

Create handouts of [Figure 11Q-1](#).

PRE-LESSON ASSIGNMENT

N/A.

APPROACH

An interactive lecture was chosen for TP1 to TP4 and TP6 to TP10 to introduce aircraft control surfaces and give an overview of them.

An in-class activity was chosen for TP5 and TP11 as it is an interactive way to provoke thought and stimulate an interest among the cadets.

INTRODUCTION

REVIEW

Review EO M231.01 (Identify the Four Forces That Act Upon an Aircraft) and EO M231.04 (Describe the Axial Movements of an Aircraft), to include:

- Weight,
- Drag,
- Thrust,
- Lift,
- Yaw,
- Pitch, and

- Roll.

OBJECTIVES

By the end of this lesson the cadet shall be expected to identify and describe the locations, operations, methods and purposes of aircraft control surfaces.

IMPORTANCE

It is important for cadets to learn about aircraft control surfaces so they can understand subsequent and related principles of flight.

Teaching Point 1

Identify Control Surface of the Empennage

Time: 5 min

Method: Interactive Lecture

An aircraft's empennage is very often called the tail section. Its most obvious parts are the vertical and horizontal stabilizers, each of which has other names as well. The vertical stabilizer is sometimes referred to as the fin and the horizontal stabilizer is sometimes referred to as the tailplane.



Use a model of a light fixed-wing aircraft with control surface detail to demonstrate the location of the empennage and associated control surfaces.

The rudder is hinged to the back of the vertical stabilizer or fin. It is used to steer (yaw) the aircraft around the vertical axis.



Show the cadets a slide or handout of the aircraft control surfaces located at [Annex M](#).

The elevator is hinged to the back of the horizontal stabilizer or tailplane. It is used to climb or descend by changing pitch around the lateral axis.

CONFIRMATION OF TEACHING POINT 1

QUESTIONS

- Q1. What two stabilizers are found on the empennage?
- Q2. Which two moveable control surfaces are located in the empennage?
- Q3. What axial movements do the elevator and the rudder produce?

ANTICIPATED ANSWERS

- A1. The vertical stabilizer, or fin, and the horizontal stabilizer, or tailplane, are on the empennage.
- A2. The rudder and the elevator are found in the empennage.
- A3. The rudder changes yaw around the vertical axis and the elevator changes pitch around the lateral axis.

Teaching Point 2**Explain How Stabilizers Reduce Unwanted Axial Movement**

Time: 5 min

Method: Interactive Lecture

The horizontal and vertical stabilizers reduce unwanted pitch and yaw. The control surfaces are held straight by the passing wind. This is because the air moving past the flat surfaces of the stabilizers tends to resist a change of direction as predicted by Newton's second law (a force must be applied to alter the motion of the air).



Use a model of a light fixed-wing aircraft with control surface detail to demonstrate the location of the vertical and horizontal stabilizers.

The vertical stabilizer, or fin, provides the aircraft with directional stability. Air moving past the fin resists any unwanted yaw around the vertical axis.

The horizontal stabilizer, or tailplane, provides the aircraft with longitudinal stability. That is, air moving past the tailplane resists unwanted roll around the longitudinal axis and unwanted pitch around the lateral axis.

CONFIRMATION OF TEACHING POINT 2**QUESTIONS**

- Q1. What axial movement does the vertical stabilizer or fin reduce?
- Q2. What axial movement does the horizontal stabilizer or tailplane reduce?
- Q3. How do stabilizers reduce unwanted axial movements?

ANTICIPATED ANSWERS

- A1. The vertical stabilizer reduces unwanted roll and unwanted yaw.
- A2. The horizontal stabilizer reduces unwanted roll and unwanted pitch.
- A3. Air moving past the flat stabilizer surfaces tends to resist any change of motion.

Teaching Point 3**Explain How the Rudder Produces Yaw**

Time: 5 min

Method: Interactive Lecture

The rudder is located at the very back of the aircraft, hinged to the trailing edge of the vertical stabilizer, or fin. The rudder can be turned left and right to give the pilot directional control. The rudder rotates the aircraft about its vertical (yaw) axis by pushing the tail to the left or to the right.



The rudder operated by itself causes the aircraft to yaw around its vertical axis.

When the rudder is turned to the right side of the fin, the moving air will push the empennage to the left, causing the aircraft to yaw to the right around its vertical axis.

When the rudder is turned to the left side of the fin, the moving air will push the empennage to the right, causing the aircraft to yaw to the left around its vertical axis.



Show the cadets a slide or handout of the rudder control system located at [Annex N](#).

The rudder is operated by the rudder bar or pedals in the cockpit. The pedals work together. When the bar or pedals are level the rudder is straight. Pressure applied to the right pedal moves the left pedal upwards and vice versa.

Pressure on the left rudder pedal displaces the rudder to the left into the airflow. This increases pressure on the left side and forces the tail to move to the right. This moves the nose of the aircraft to the left. Conversely, pressure applied to the right pedal moves the rudder to the right. The tail moves to the left and the aircraft yaws to the right.

CONFIRMATION OF TEACHING POINT 3

QUESTIONS

- Q1. Where is the rudder located?
- Q2. What is the rudder used for?
- Q3. What controls the rudder?

ANTICIPATED ANSWERS

- A1. The rudder is hinged to the trailing edge of the vertical stabilizer of fin.
- A2. To produce controlled yaw by rotating the aircraft about its vertical (yaw) axis.
- A3. A set of pedals in the cockpit.

Teaching Point 4

Explain How the Elevator Controls Pitch

Time: 5 min

Method: Interactive Lecture

Both the left and right portions of the horizontal stabilizer, or tailplane, have a moveable control surface known as an elevator.



The elevator rotates the aircraft about its lateral (pitch) axis by pushing the empennage, or tail-section, up or down.

The elevator, of which there is normally a left and a right section, is located on the trailing edge of the horizontal stabilizer. It is used to give the pilot lateral control. Raising the elevator into the moving air above the tailplane will push the empennage down, thus raising the aircraft's nose. Alternately, lowering the elevator down into the air moving below the tailplane will push the empennage up, thus lowering the aircraft's nose. These pitch movements take place around the lateral axis.

The pilot controls the elevator by pushing or pulling on the control column.

Pushing the control column forward lowers the elevator into the wind passing under the tailplane, pushing the empennage up. This causes the aircraft's nose to drop and the aircraft will descend.

Pulling the control column back raises the elevator into the wind passing over the tailplane, pushing the empennage down. This causes the aircraft's nose to rise and the aircraft will climb.



Show the cadets a slide or handout of the elevator control system located at [Annex O](#).

CONFIRMATION OF TEACHING POINT 4

QUESTIONS

- Q1. Where is the elevator control surface located?
- Q2. What axial movement does the elevator control?
- Q3. How does the pilot operate the elevator?

ANTICIPATED ANSWERS

- A1. The elevator control surface is located on the trailing edge of the horizontal stabilizer.
- A2. The elevator controls pitch around the aircraft's lateral axis.
- A3. The pilot pushes on the control column to descend and pulls back to climb.

Teaching Point 5

Enact Control Surface Movements Controlled by a Pilot

Time: 5 min

Method: In-class Activity



Review the cockpit controls that move the associated empennage control surfaces. Have the cadets enact control movements with a "pilot" calling out pedal and stick movements to the remainder of the class, who then act as pitch and yaw control surfaces.

ACTIVITY

OBJECTIVE

The objective of this activity is to have the cadets learn what cockpit control causes which control surface to move.

RESOURCES

N/A.

ACTIVITY LAYOUT

Form the cadets into a circle. Have the cadet who is the pilot seated where the other cadets can see the pilot's movements.

ACTIVITY INSTRUCTIONS

One cadet is designated the pilot and is seated in the clear view of the standing cadets. The seated cadet, who is the pilot, will pretend to move pedals and pretend to move a control column, but only one at a time.

Divide the remainder of the class into “rudders” and “elevators”. The standing cadets must mimic the correct moving control surface with their right arm (elevator: up and down) or left arm (rudder: left and right). After a minute of imaginary flight, ask the cadets to perform both elevator and rudder movements with both right and left hands simultaneously.

SAFETY

N/A.

CONFIRMATION OF TEACHING POINT 5

The cadets' participation in the activity will serve as the confirmation of this TP.

Teaching Point 6

Identify the Wing Control Surfaces

Time: 5 min

Method: Interactive Lecture



Show the cadets a slide or handout of the aircraft control surfaces located at [Annex M](#).

AILERONS

The surfaces that control roll are located near the ends of the wings on the trailing edge. They are called ailerons.



Ailerons operate simultaneously, but in opposite directions. When the right aileron rises to push the right wing down, the left aileron lowers to push the left wing up.

The down-going aileron increases the wing's lift and the up-going aileron decreases the wing's lift. Therefore, the left wing's lift increases and the right wing's lift decreases. The left wing lifts and the right wing descends, so the aircraft rolls to the right and keeps rolling until the ailerons are retracted.

To recover from the roll, the ailerons must be applied in the opposite direction until the aircraft is level and the ailerons are then again neutralized for level flight.



Show the cadets a slide or handout of the aileron control surface located at [Annex P](#).

WING FLAPS



Show the cadets a slide or handout of the aircraft control surfaces located at [Annex M](#).

Flaps are located nearer the fuselage on the trailing edge of the wing.

Both flaps operate together. They are raised together and they are lowered together with one control mechanism.

Flaps are lowered to create lift and to slow the aircraft. When they are lowered into the air moving past the under-surface of the wing, they slow the air and the air pushes them up, creating lift while simultaneously slowing the aircraft by creating both form drag and induced drag. When fully lowered, the drag created exceeds the lift generated.



Flaps allow for shorter landings.

CONFIRMATION OF TEACHING POINT 6

QUESTIONS

- Q1. Which two wing control surfaces always move in opposite directions?
- Q2. What axial movement do ailerons control?
- Q3. How do flaps help with landings?

ANTICIPATED ANSWERS

- A1. The left aileron and the right aileron.
- A2. Ailerons control roll around the longitudinal axis.
- A3. Flaps slow the aircraft allowing shorter landings.

Teaching Point 7

Explain the Operation of Ailerons

Time: 5 min

Method: Interactive Lecture

Ailerons lift one wing and lower the opposite wing simultaneously as a single cockpit control is operated to produce roll.



Ailerons move in opposite directions to each other and are controlled by operating the control column from side to side.

When the control column is moved to the right, the left aileron moves down and the right aileron moves up so the aircraft rolls to the right into a banked position.

When the control column is moved to the left, the left aileron goes up and the right one moves down so the aircraft rolls to the left into a banked position.

When the pilot wants to stop the roll and stay in a banked position, the control column is returned to centre and the ailerons retract. To recover from the roll into a level position, the ailerons must be extended into the opposite directions. They are then retracted for level flight.

CONFIRMATION OF TEACHING POINT 7

QUESTIONS

- Q1. How do ailerons produce roll around the longitudinal axis?
- Q2. How does the pilot control the ailerons?
- Q3. How does the pilot stop the roll and stay in the banked position?

ANTICIPATED ANSWERS

- A1. As one aileron is raised the other is lowered so they push up on one wing and down on the other simultaneously.
- A2. The pilot moves the control column to the left to roll to the left and to the right to roll to the right.
- A3. To stop the roll and stay in a bank, the pilot returns the control column to centre.

Teaching Point 8

Explain the Operation of Flaps

Time: 5 min

Method: Interactive Lecture

The aircraft's flaps are also located on the trailing edge of the wing, as are ailerons, but the flaps are placed nearer to the fuselage.

Flaps are used to generate lift at the expense of airspeed and both left and right flaps operate simultaneously.



Show the cadets a slide or handout of the aircraft control surfaces located at [Annex M](#).

Both flaps operate together. They are raised together and lowered together.

Flaps are lowered to create lift and to slow the aircraft. When they are lowered into the air moving past the under-surface of the wing, they slow the air and the air pushes them up, creating lift while simultaneously slowing the aircraft by creating both form drag and induced drag. When fully lowered, the drag created exceeds the lift generated.



Flaps allow for shorter and safer landings.

CONFIRMATION OF TEACHING POINT 8

QUESTIONS

- Q1. Where are an aircraft's flaps located?
- Q2. What are flaps used for?
- Q3. How do flaps affect an aircraft's landing performance?

ANTICIPATED ANSWERS

- A1. An aircraft's flaps are located on the trailing edge of the wings, close to the fuselage.
- A2. Flaps are used to slow the aircraft and simultaneously generate lift.
- A3. By slowing the aircraft, flaps allow shorter and safer landings.

Teaching Point 9**Explain the Use of Trim Tabs**

Time: 5 min

Method: Interactive Lecture

Trim tabs were developed to hold control surfaces in position without constant control pressure from the pilot.

A pilot has to do a lot of work to hold control surfaces in position. When the pilot has set a course in a crosswind, the control surfaces often have to stay in a working position for long periods of time.

To save the pilot from having to do this, trim tabs were invented. A trim tab is a small, adjustable control surface that can be extended from the trailing edge of an aircraft's control surface. So, it is a control surface that is hinged onto a larger control surface. The wind, pushing on the trim tab when it is extended, provides the force necessary to hold the aircraft's main control surface in position.



Trim tabs are often found on the trailing edge of the rudder, the elevators and on the ailerons.

CONFIRMATION OF TEACHING POINT 9

QUESTIONS

- Q1. What are trim tabs for?
- Q2. Where are trim tabs located?
- Q3. How does a trim tab work?

ANTICIPATED ANSWERS

- A1. Trim tabs hold control surfaces in position without constant control pressure being applied by the pilot.
- A2. Trim tabs are often located on the trailing edge of control surfaces.
- A3. Air pushes on the trim tab when it is extended and provides force to hold the aircraft control surface in position.

Teaching Point 10**Explain the Use of Dynamically Balanced Control Surfaces**

Time: 5 min

Method: Interactive Lecture

Dynamically balanced control surfaces were developed to make pilots' work easier. These surfaces use air pressure to help move the controls by having a portion of the control surface in front of its own hinge to catch the passing air. This takes the load off the pilot's control mechanism. That way, the wind itself helps push the control surface into the position that the pilot has selected, making the controls feel lighter.

CONFIRMATION OF TEACHING POINT 10

QUESTIONS

- Q1. Why are control surfaces dynamically balanced?
- Q2. What do dynamically balanced controls use to help the pilot?
- Q3. How does dynamic balance get the wind to help move the control surfaces?

ANTICIPATED ANSWERS

- A1. Control surfaces are dynamically balanced to make them easier to operate.
 - A2. Dynamically balanced controls use the force of the wind to help operate the control surfaces.
 - A3. The moving air helps operate the control surface because part of the control surface is designed to project out into the wind in front of its own hinge to catch the passing air.
-

Teaching Point 11**Colour and Label the Control Surfaces in a Drawing of an Aircraft**

Time: 5 min

Method: In-class Activity

ACTIVITY

OBJECTIVE

The objective of this activity is to have the cadets label the control surfaces shown on a scale drawing.

RESOURCES

Coloured pencils.

ACTIVITY LAYOUT

N/A.

ACTIVITY INSTRUCTIONS

Give each cadet a copy of the aircraft drawing located at [Annex Q](#) and access to a variety of coloured pencils. Have each cadet colour the control surfaces and label them.

Supervise and answer questions during this activity to ensure that the colouring and labelling is done accurately.

SAFETY

N/A.

CONFIRMATION OF TEACHING POINT 11

The cadets' participation in the activity will serve as the confirmation of this TP.

END OF LESSON CONFIRMATION**QUESTIONS**

- Q1. What is one moveable aircraft control surface and what is it used for?
- Q2. What is a second moveable aircraft control surface and what is it used for?
- Q3. What is a third moveable aircraft control surface and what is it used for?
- Q4. What is a fourth moveable aircraft control surface and what is it used for?
- Q5. What is a fifth moveable aircraft control surface and what is it used for?

ANTICIPATED ANSWERS

- A1. Elevators are used to produce controlled pitch of the aircraft.
 - A2. Rudders are used to produce controlled yaw of the aircraft.
 - A3. Ailerons are used to produce controlled roll of the aircraft.
 - A4. Flaps are used to create lift and slow the aircraft simultaneously.
 - A5. Trim tabs are used to hold the control surfaces where the pilot wants them.
-

CONCLUSION**HOMEWORK/READING/PRACTICE**

N/A.

METHOD OF EVALUATION

N/A.

CLOSING STATEMENT

Control surfaces are important parts of an aircraft, which control movement around the aircraft's three axes. Knowing about them is important for understanding the principles of flight.

INSTRUCTOR NOTES/REMARKS

N/A.

REFERENCES

- C3-116 A-CR-CCP-263/PT-001/(ISBN 0-9680390-5-7) MacDonald, A. F. and Pepler, I. L. (2000). *From the Ground Up: Millennium Edition*. Ottawa, ON: Aviation Publishers Co. Limited.

THIS PAGE INTENTIONALLY LEFT BLANK



ROYAL CANADIAN AIR CADETS
PROFICIENCY LEVEL TWO
INSTRUCTIONAL GUIDE



SECTION 6

EO C231.01 – OPERATE AN EXPERIMENTAL WING

Total Time: 60 min

PREPARATION

PRE-LESSON INSTRUCTIONS

Resources needed for the delivery of this lesson are listed in the lesson specification located in A-CR-CCP-802/PG-001, Chapter 4. Specific uses for said resources are identified throughout the Instructional Guide within the TP for which they are required.

Review the lesson content and become familiar with the material prior to delivering the lesson.

Create slides or copy handouts of [Figures 11R-1](#) to [11R-4](#) for each group.

Gather cardboard boxes suitable for constructing a wind tunnel as described in TP2.

PRE-LESSON ASSIGNMENT

N/A.

APPROACH

An interactive lecture was chosen for TP1 to introduce wind tunnels and give an overview of them.

An in-class activity was chosen for TP2 to TP4 as it is an interactive way to provoke thought and stimulate an interest among cadets.

INTRODUCTION

REVIEW

The review for this lesson is from EO M231.01 (Identify the Four Forces That Act Upon an Aircraft) and will include:

- weight,
- drag,
- thrust, and
- lift.

OBJECTIVES

By the end of this lesson the cadet shall be expected to have helped to assemble a wind tunnel and to have operated an experimental wing in the wind tunnel.

IMPORTANCE

It is important for cadets to operate an experimental wing so they can experience the change in lift that follows a change in angle of attack.

Teaching Point 1

Identify the Parts of a Wind Tunnel

Time: 5 min

Method: Interactive Lecture

PARTS OF A WIND TUNNEL

Settling Chamber. The purpose of the settling chamber is to straighten the airflow.

Contraction Cone. The contraction cone takes a large volume of low-velocity air and reduces it to a small volume of high-velocity air without creating turbulence.

Test Section. The test section is where the test article and sensors are placed.

Diffuser. The diffuser slows the speed of airflow in the wind tunnel.

Drive Section. The drive section provides the force that causes the air to move through the wind tunnel.



Show the cadets a slide or handout of the five parts of a wind tunnel shown in [Figure 11R-1](#).

There are two types of wind tunnels: open-loop and closed-loop. The difference is whether or not the air is recirculated in the tunnel. The wind tunnel to be built in this lesson is an open-loop wind tunnel.

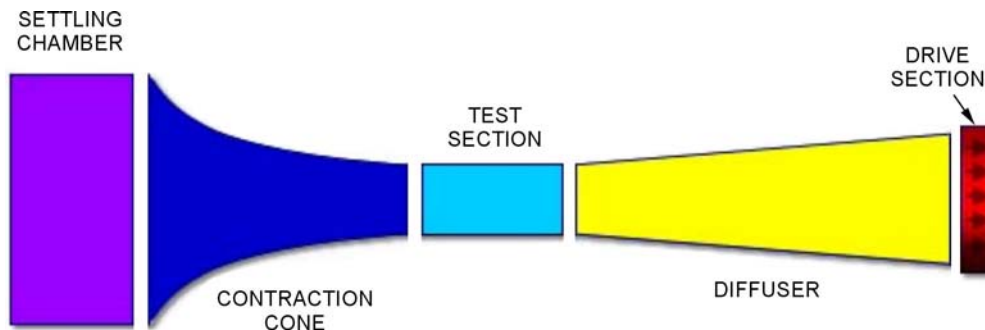

"NASA's Observatorium", The Parts of a Wind Tunnel. Retrieved 19 March 2007, from <http://sln.fi.edu/flights/first/tunnelparts/index.html>

Figure 11-6-1 A Simple Wind Tunnel



Not every improvised wind tunnel will have a settling chamber, contraction zone and diffuser, but these design elements can each improve the wind tunnel's performance by smoothing airflow.

CONFIRMATION OF TEACHING POINT 1

QUESTIONS

- Q1. What is the purpose of a wind tunnel settling chamber?
- Q2. What is the purpose of a wind tunnel diffuser?
- Q3. What is the purpose of a wind tunnel contraction cone?

ANTICIPATED ANSWERS

- A1. The purpose of the settling chamber is to straighten the airflow.
- A2. The diffuser slows the speed of airflow in the wind tunnel.
- A3. The contraction cone takes a large volume of low-velocity air and reduces it to a small volume of high-velocity air without creating turbulence.

Teaching Point 2**Assemble a Wind Tunnel**

Time: 15 min

Method: In-class Activity

ACTIVITY

OBJECTIVE

The objective of this activity is to have the cadets, organized in groups but working as a coordinated team, assemble a wind tunnel for flying experimental wings.

RESOURCES

- Cardboard boxes, including two with cardboard separator inserts for packing glass bottles,
- Blank OHP slides,
- Duct tape, and
- Two multi-speed fans.

ACTIVITY LAYOUT

Place a table large enough to hold the wind tunnel and fans in an area that will provide room for groups of no more than four cadets to work comfortably, with access to power for the fans.

ACTIVITY INSTRUCTIONS

Have the cadets make a wind tunnel out of five boxes taped together with all ends open. The wind tunnel should be large enough that both hands will fit into it easily. For both the settling chamber and the drive section, use boxes that include cardboard separators for shipping glass bottles. The cardboard separators will “honeycomb” or straighten the swirling air currents from the electric fan.

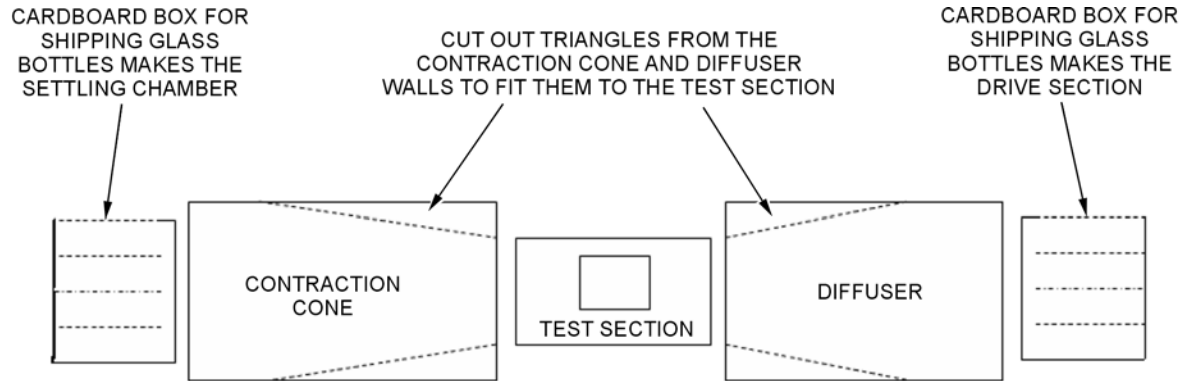

D Cds 3, 2007 Ottawa, ON: Department of National Defence

Figure 11-6-2 Parts of a Cardboard Wind Tunnel

The parts of the wind tunnel can be divided between groups of cadets but, when completed, the wind tunnel components must fit together so that each section fits tightly inside the next section.

1. Shape the contraction zone and diffuser sections by cutting out triangles of unwanted cardboard as shown at [Figure 11R-2](#). Make cuts straight and smooth so the resulting joint can be made airtight.
2. Cut “windows” in the test section and cover over with OHP slide material.
3. Tape all edges and holes airtight and ensure the inside of the wind tunnel is smooth to allow the air to pass through without turbulence. Seal all box joints with duct tape.
4. Place an electric fan so that it blows into the cardboard honeycomb of the settling chamber. The fan must be run at a speed that does not produce unreasonable turbulence, yet fast enough that it pushes a large volume of air through the glass bottle separators. Place another fan at the exit of the drive section facing away from the wind tunnel to pull air from the wind tunnel.

SAFETY

N/A.

CONFIRMATION OF TEACHING POINT 2

The cadets’ participation in the activity will serve as the confirmation of this TP.

Teaching Point 3

Form Airfoil Shapes for Testing in the Wind Tunnel

Time: 10 min

Method: In-class Activity

ACTIVITY

OBJECTIVE

The objective of this activity is to have the cadets create their own airfoil shapes for testing in the wind tunnel.

RESOURCES

- File folders (letter size),

- Handout of [Figures 11R-3](#) and [11R-4](#) for each group of cadets,
- Tape, and
- Locally available materials for constructing experimental wings.

ACTIVITY LAYOUT

N/A.

ACTIVITY INSTRUCTIONS

- Divide the class into groups of no more than four, giving each group a file folder and handout of [Figures 11R-3](#) and [11R-4](#).
- If file folders are used to make airfoil shapes, have the cadets bend one cover of the file folder into a curved (cambered) shape and tape it into place as shown in [Figure 11R-3](#). The airfoil should be pressed into the shape shown in [Figure 11R-4](#).

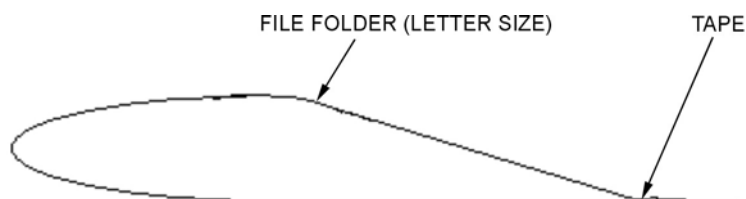

D Cds 3, 2007 Ottawa, ON: Department of National Defence

Figure 11-6-3 File Folder Airfoil

SAFETY

If locally available materials, such as balsa wood, knives etc., are used for constructing experimental wings instead of file folder airfoils, ensure safe practices are followed. Careful supervision will prevent unsafe use of materials or unsafe actions.

CONFIRMATION OF TEACHING POINT 3

The cadets' participation in the activity will serve as the confirmation of this TP.

Teaching Point 4

Place Airfoils in the Wind Tunnel and Compare Lift and Drag

Time: 25 min

Method: In-class Activity

ACTIVITY

OBJECTIVE

The objective of this activity is to have the cadets suspend experimental wings in the operating wind tunnel and make changes in the wing's angle of attack, observing the change in lift.

RESOURCES

- Experimental wings created in TP3,
- String or dental floss, and

- Stapler.

ACTIVITY LAYOUT

Place the wind tunnel created in TP2 in a location that provides room for groups of no more than four cadets to work comfortably, with access to power for operating the wind tunnel fans.

ACTIVITY INSTRUCTIONS

1. Have the cadets poke tiny holes in the roof and floor of the wind tunnel test section where the trailing edge of the experimental wing will be located.
2. Poke tiny holes in the window walls where the leading edge of the experimental wing will be located.
3. Run dental floss from window wall to window wall of the test section, passing through the interior of the experimental wing to be tested, at the wing's leading edge. This will suspend the experimental wing in the centre of the test section where it can be controlled and viewed.
4. Run dental floss from roof to floor of the test section, attaching the string to the trailing edge of the experimental wing with staples. This will allow the angle of attack to be changed by pulling on the dental floss under the test section to increase the angle of attack, or pulling on the dental floss above the test section to decrease the angle of attack.
5. With two cadets holding the ends of the horizontal string and two cadets holding the ends of the vertical string, turn on the fan.
6. Ask the cadets with the vertical string to increase the angle of attack. The cadets holding the horizontal string will detect an increase in lift.
7. Have the cadets trade positions.
8. Repeat with each group of cadets.

As a concurrent activity, while cadets are waiting for their turn on the wind tunnel, they will improve their experimental wing or develop different shapes for testing.

SAFETY

Ensure the fan has a safety guard around the blade and turn fan off when not testing a wing. Ensure that the fan is not located where a cadet might touch it accidentally during the activity.

CONFIRMATION OF TEACHING POINT 4

The cadets' participation in the activity will serve as the confirmation of this TP.

END OF LESSON CONFIRMATION

The cadets' participation in the activities will serve as the confirmation of this lesson.

CONCLUSION

HOMEWORK/READING/PRACTICE

N/A.

METHOD OF EVALUATION

N/A.

CLOSING STATEMENT

A wind tunnel provides an inexpensive opportunity to test an airfoil design and compare it to other designs, without being exposed to the dangers of a test flight.

INSTRUCTOR NOTES/REMARKS

If room permits, the wind tunnel can be preserved for future use instead of being discarded. If a glider is available from lesson C231.02 (Fly a Paper Colditz Glider) cadets can suspend that in the test chamber and perform control surface experiments with it.

REFERENCES

- C3-091 (ISBN 1-55652-477-3) Carson, M.K. (2003). *The Wright Brothers for Kids: How They Invented the Airplane*. Chicago, IL: Chicago Review Press.
- C3-093 NASA. (1996). *NASA's Observatorium Teacher's Guide*. Retrieved 12 February 2007, from http://observe.arc.nasa.gov/nasa/aero/tunnel/tunnel_parts.html.
- C3-116 A-CR-CCP-263/PT-001/(ISBN 0-9680390-5-7) MacDonald, A. F. & Pepler, I. L. (2000). *From the Ground Up: Millennium Edition*. Ottawa, ON: Aviation Publishers Co. Limited.

THIS PAGE INTENTIONALLY LEFT BLANK



ROYAL CANADIAN AIR CADETS
PROFICIENCY LEVEL TWO
INSTRUCTIONAL GUIDE



SECTION 7

EO C231.02 – FLY A PAPER COLDITZ GLIDER

Total Time:	60 min
-------------	--------

PREPARATION

PRE-LESSON INSTRUCTIONS

Resources needed for the delivery of this lesson are listed in the lesson specification located in A-CR-CCP-802/PG-001, Chapter 4. Specific uses for said resources are identified throughout the Instructional Guide within the TP for which they are required.

Review the lesson content and become familiar with the material prior to delivering the lesson.

Copy the paper Colditz glider assembly instructions and templates located at [Annex S](#) for each cadet. [Figures 11S-3](#) and [11S-4](#) require photocopy magnification so that the parts layout section fits a 5 x 8 inch standard index card.

Construct a paper Colditz glider for demonstration purposes.

PRE-LESSON ASSIGNMENT

N/A.

APPROACH

An interactive lecture was chosen for TP1 as it introduces paper gliders, orients the cadets to the topic and generates interest.

An in-class activity was chosen for TP2 and TP3 as it is an interactive way to provoke thought and stimulate an interest among cadets and to confirm the cadets' comprehension of the material.

A group discussion was chosen for TP4 as it allows the cadets to interact with their peers and share their knowledge, experiences, opinions and feelings about paper gliders.

INTRODUCTION

REVIEW

N/A.

OBJECTIVES

By the end of this lesson the cadet shall be expected to construct and fly a paper Colditz glider.

IMPORTANCE

Constructing and flying paper gliders in a fun and challenging way allows cadets to observe some of the principles of flight in action.

Teaching Point 1

Explain the History and Design of a Paper Colditz Glider

Time: 15 min

Method: Interactive Lecture

During World War II, Colditz Castle in German Saxony was used as a prisoner of war camp. Built on rocks high above the town of Colditz and overlooking the valley of the River Mulde, the huge structure seemed the ideal place for a high security prison. The inmates proved that this was a mistake. Between 1939 and 1945 there was a constant battle of wits between Allied officers and German guards that turned Colditz Castle into an international “Escape School”. Over 300 daring escape attempts earned “Oflag IV c” (Officers’ Camp IV c, Colditz) the reputation of a bad boys’ camp and made the Castle notorious. Allied Officers from Australia, Belgium, Canada, Czechoslovakia, France, Great Britain, India, Netherlands, New Zealand, Poland, Serbia, South Africa and the USA were imprisoned in the old castle.

Flying Officer Bill Goldfinch, a British prisoner of war, designed a small glider for an escape. Fellow prisoners built it using materials in the camp. Floorboards became wing spars, the ribs and frame were made from bed slats and control lines were electrical wires, all stealthily obtained. The covering was cotton, which came from sleeping bags sealed with slurry-type paste made by boiling down prison ration millet.



Colditz Castle is now a museum. Cadets can find out more about Oflag IV c and the prisoners by visiting the museum Website: <http://www.colditz-4c.com/index.html>.

When developing this escape plan, the prisoners had many things to consider. Ensuring the effective flight capability of their glider required attention to the same principles that concern this lesson.

BASIC PRINCIPLES OF FLIGHT

Weight. The force that attracts all matter and pulls objects to the Earth’s surface. In gliding, gravity provides the power to make the glider move. The wings change this downward pull (gravity) into forward motion (thrust) by acting on the passing air.

Lift. Any force that exerts an upward pull on the glider to overcome gravity.

Drag. The air’s resistance to the glider’s forward motion.

Thrust. Any force that propels the glider forward.

Angle of Attack. The angle at which the wing goes through the air.

Stall. When the wing’s angle of attack is too great, the wing no longer produces lift.

A wing increases the speed of the airflow over its upper surface so that the pressure in this area is reduced. This is accomplished by curving the upper surface, which is known as camber. The distance from front to back along the curved surface is greater than the distance under the straight lower surface. Because the air molecules flowing along the curve have further to travel than the ones beneath, they increase their speed and become spaced further apart. This faster moving air exerts less pressure, which means that a partial vacuum is created above the wing.

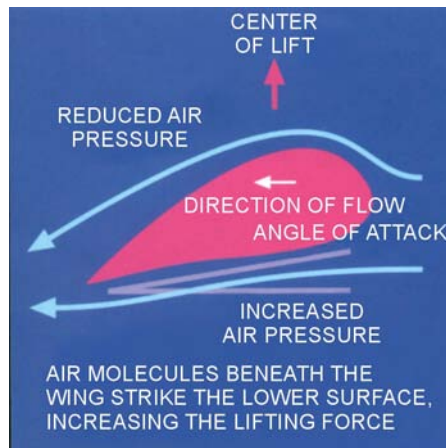

Schmidt, N., *Fabulous Paper Gliders*, Sterling Publishing Company (p. 19)

Figure 11-7-1 Lift

PAPER GLIDER PARTS

A paper glider is constructed with three main parts made up of smaller pieces built up in layers:

- fuselage with a vertical stabilizer,
- wings, and
- horizontal stabilizer.



Parts templates and detailed instructions are located at [Annex S](#). Paper glider construction will be explained in TP2.

TRIMMING FOR FLIGHT



The paper glider to be built in TP2 will be more stable in flight if the following requirements for trimming are kept in mind during construction.

The control surfaces of the paper glider should be arranged to reduce roll, pitch and yaw. If the paper glider has an undesirable tendency to turn, bend the rudder slightly away from the direction of the turn. This should push the tail back into a straight line.

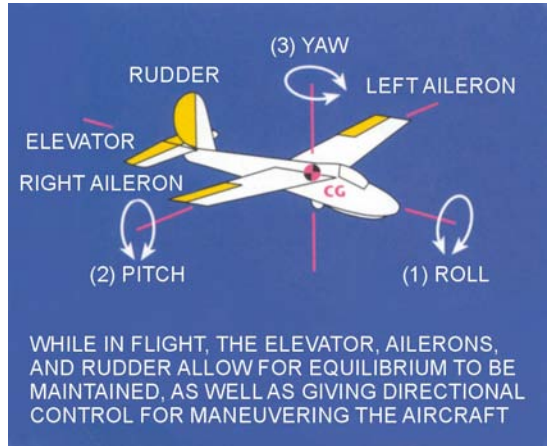

Schmidt, N., *Fabulous Paper Gliders*, Sterling Publishing Company (p. 22)

Figure 11-7-2 Trimming for Flight

Angle the wings upward from the fuselage to inhibit roll. This is called a dihedral angle. As one wing drops and the other rises, the dropping wing will generate more lift as it approaches the horizontal and the rising wing will generate less lift as it approaches the vertical.

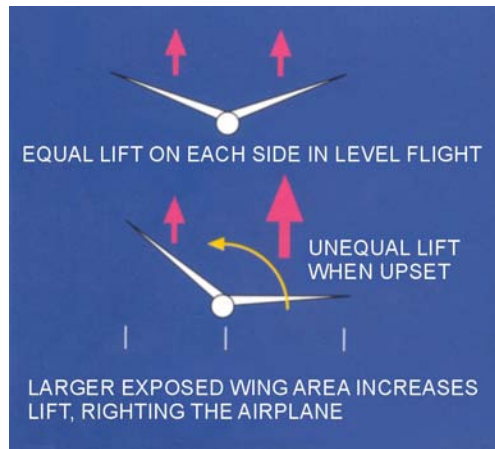

Schmidt, N., *Fabulous Paper Gliders*, Sterling Publishing Company (p. 21)

Figure 11-7-3 Controlling Roll

A paper glider that loses altitude too rapidly may be improved by keeping the paper glider's centre of gravity ahead of lift or by increasing the angle of the elevators at the rear of the horizontal stabilizers to lift the nose.

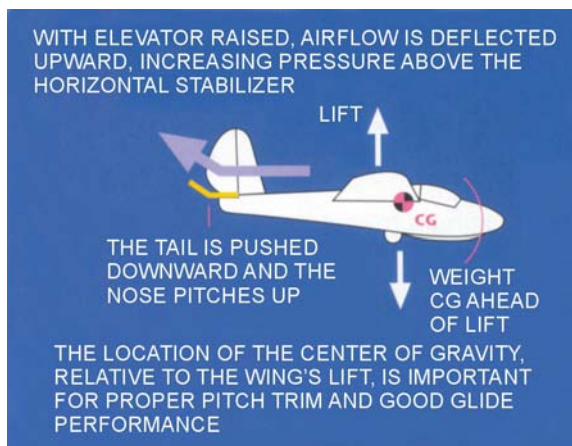

Schmidt, N., Fabulous Paper Gliders, Sterling Publishing Company (p. 23)

Figure 11-7-4 Lifting the Nose

The wing's ability to provide lift can be improved by adjusting the shape of the curvature. The curve should be very slight (refer to [Figure 11S-2](#)).



Schmidt, N., Fabulous Paper Gliders, Sterling Publishing Company (p. 8)

Figure 11-7-5 Adjusting Wing Curvature (Camber)

FLYING TIPS

Pick up and hold paper gliders by the nose. Never lift them by the wings or tail; this will distort their aerodynamic shape.

Examine the glider thoroughly from the front, back, top, bottom, and each side. Check for parts that appear bent or twisted. Each side must be exactly like the other. A paper glider must be symmetrical in all respects.

When throwing, hold the fuselage between the thumb and forefinger just behind the paper glider's centre of gravity. Throw it gently with a straight motion, not as if it were a baseball. A paper glider flies best at only one speed. Throwing it too hard will cause it to climb sharply, stall, and dive to the ground, or do a complete loop.

CONFIRMATION OF TEACHING POINT 1

QUESTIONS

- Q1. Why are the wings on most aircraft angled upward from the fuselage?
- Q2. When gliding, what force creates thrust to overcome drag?
- Q3. When gliding, what motion is necessary to create lift?

ANTICIPATED ANSWERS

- A1. The wings on most aircraft are angled upward from the fuselage to provide roll stability.
- A2. The force of gravity creates thrust to overcome drag.
- A3. Forward motion is necessary to create lift.

Teaching Point 2

Construct a Paper Colditz Glider

Time: 20 min

Method: In-class Activity

ACTIVITY

OBJECTIVE

The objective of this activity is to have the cadets construct a paper Colditz glider.

RESOURCES

- Index card stock 5 x 8 inch (two per cadet),
- Scissors (one pair per cadet),
- Fast-drying glue,
- Ruler (one per cadet),
- Pencil (one per cadet), and
- Glider templates located at [Annex S](#) (one set per cadet).

ACTIVITY LAYOUT

N/A.

ACTIVITY INSTRUCTIONS

1. Provide each cadet with the instructions and templates located at [Annex S](#) and resources as needed.
2. Have the cadets cut the parts layout section from each photocopy, as indicated on the page, to fit a 5 x 8 inch standard index card. Lightly glue the layouts to the card by applying a small spot of glue to the areas between the parts on the rear side, being careful to align the two parts.

3. Before beginning to cut out the parts, score those parts that will need to be bent later and cut opening slits where indicated. Score and cut precisely on the lines.
4. Cut out each part shown. This must be done carefully since the success or failure of every other step depends on accurately made parts. Keep track of the parts by lightly writing the part number in pencil on the backside of each part.
5. Build the glider. Begin with the 1F fuselage part, adding the other smaller parts to each side to complete the fuselage. Align parts carefully. Add drawing decoration when the glue is dry.



Ensure every cadet is finished construction before proceeding to TP3.

SAFETY

N/A.

CONFIRMATION OF TEACHING POINT 2

The cadets' participation in the activity will serve as the confirmation of this TP.

Teaching Point 3

Fly a Paper Colditz Glider

Time: 15 min

Method: In-class Activity

ACTIVITY

OBJECTIVE

The objective of this activity is to have the cadets fly a paper Colditz glider and compare its performance with the flight of other paper Colditz gliders.

RESOURCES

N/A.

ACTIVITY LAYOUT

N/A.

ACTIVITY INSTRUCTIONS

Form cadets into a launching line.

Paper Colditz gliders are to be launched forward of the launching line and the paper gliders which travel the furthest and which fly the longest are to be noted by the instructor.

With the cadets, analyze and correct the performance of gliders that did not fly effectively and have the cadets try again.

The very successful gliders that finally go the furthest and fly the longest will be examined in TP4.

SAFETY

Gliders must not be launched when anyone is forward of the launching line.

CONFIRMATION OF TEACHING POINT 3

The cadets' participation in the activity will serve as the confirmation of this TP.

Teaching Point 4

Discuss Flying Paper Colditz Gliders

Time: 5 min

Method: Group Discussion

BACKGROUND KNOWLEDGE



The point of the group discussion is to draw the following information from the group using the tips for answering/facilitating discussion and the suggested questions provided.

Paper is a relatively unstable material and it may be necessary to readjust the planes after every few flights. Cadets may feel frustration about erratic performance but this unpredictable quality of paper gliders can be part of the joy of flying them.

GROUP DISCUSSION



TIPS FOR ANSWERING/FACILITATING DISCUSSION

- Establish ground rules for discussion, e.g. everyone should listen respectfully; don't interrupt; only one person speaks at a time; no one's ideas should be made fun of; you can disagree with ideas but not with the person; try to understand others as much as you hope they understand you; etc.
- Sit the group in a circle, making sure all cadets can be seen by everyone else.
- Ask questions that will provoke thought; in other words avoid questions with yes or no answers.
- Manage time by ensuring the cadets stay on topic.
- Listen and respond in a way that indicates you have heard and understood the cadet. This can be done by paraphrasing their ideas.
- Give the cadets time to respond to your questions.
- Ensure every cadet has an opportunity to participate. One option is to go around the group and have each cadet answer the question with a short answer. Cadets must also have the option to pass if they wish.
- Additional questions should be prepared ahead of time.

QUESTIONS

- Q1. How do you feel about paper glider aviation?
- Q2. What did you enjoy most about this activity?

- Q3. What things contributed to the success of the glider's flight?
- Q4. How might glider performance be improved?
- Q5. How might glider performance be made more consistent?



Other questions and answers will develop throughout the group discussion. The group discussion should not be limited to only those suggested.



Reinforce those answers given and comments made during the group discussion, ensuring the teaching point has been covered.

CONFIRMATION OF TEACHING POINT 4

The cadets' participation in the group discussion will serve as the confirmation of this TP.

END OF LESSON CONFIRMATION

SUGGESTED QUESTIONS

- Q1. What characteristics were common to the paper gliders that flew the furthest?
- Q2. What characteristics were common to paper gliders that turned in flight?
- Q3. How can a paper glider be prevented from stalling?

ANTICIPATED ANSWERS

- A1. Common characteristics were similar camber, similar pitch, straight rudder, etc.
- A2. The common characteristic was that the rudder was not straight in line with the fuselage.
- A3. To prevent a paper glider from stalling, the angle of attack of the wing can be reduced.
-

CONCLUSION

HOMEWORK/READING/PRACTICE

N/A.

METHOD OF EVALUATION

N/A.

CLOSING STATEMENT

Cadets can improve the design and operation of a paper glider even if it is efficient already; careful application of flight principles may improve even successful paper gliders.

INSTRUCTOR NOTES/REMARKS

It is recommended that the two periods required for this EO be scheduled consecutively.

If the weather is not suitable to fly the paper Colditz gliders outdoors, flights may take place indoors.

REFERENCES

- C3-017 (ISBN 1-895569-23-0) Schmidt, N. (1998). *Fabulous Paper Gliders*. New York, NY: Sterling Publishing.
- C3-058 (ISBN 1-4027-3034-9) Schmidt, N. (2005). *Paper Creations Paper Airplanes*. New York, NY: Sterling Publishing Company.
- C3-094 Colditz Museum. (2005). *Colditz Glider*. Retrieved 23 February 2007, from <http://www.colditz-4c.com/glider.htm>.

PAPER AIRPLANE ASSEMBLY INSTRUCTIONS

1. Fold paper down the centre lengthwise.
2. Fold the two upper corners down to the centreline.
3. Fold the two folded corners down to the centreline.

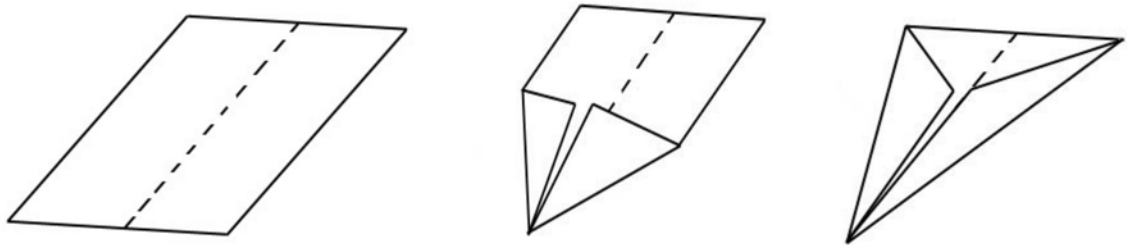

4. Fold the plane in half.
5. Fold one wing down, flip the plane over, and fold the other wing down.
6. Open the plane and fold the wing tips up.

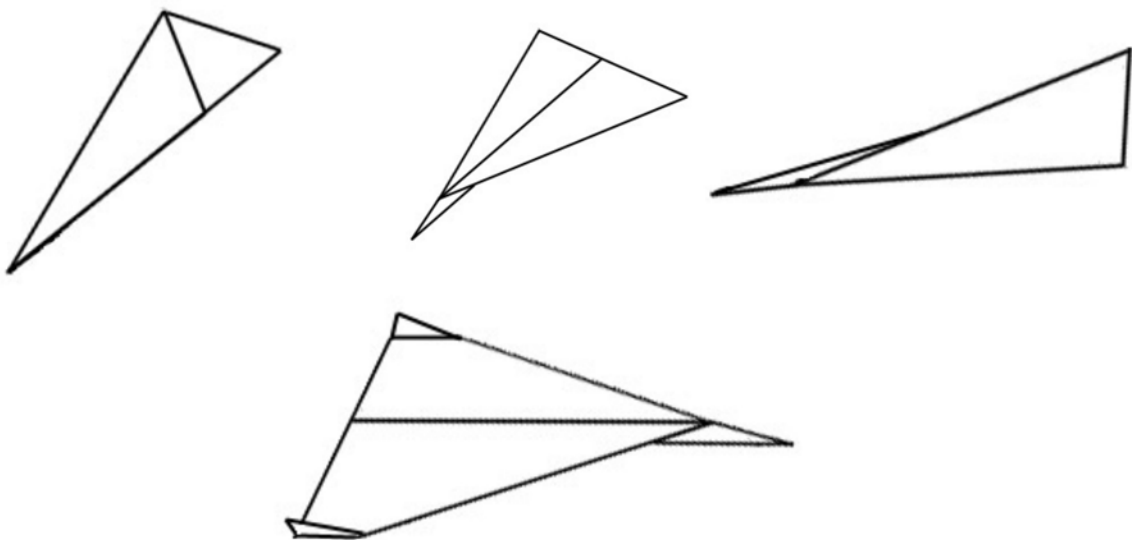

*"NASAexplores", Express Lessons and Online Resources. Retrieved 7 March 2007,
from http://www.nasaexplores.com/show_58_student_st.php?id=02123190203*

Figure 11A-1 Paper Plane Assembly Instructions

THIS PAGE INTENTIONALLY LEFT BLANK

FOUR FORCES THAT ACT UPON AN AIRCRAFT

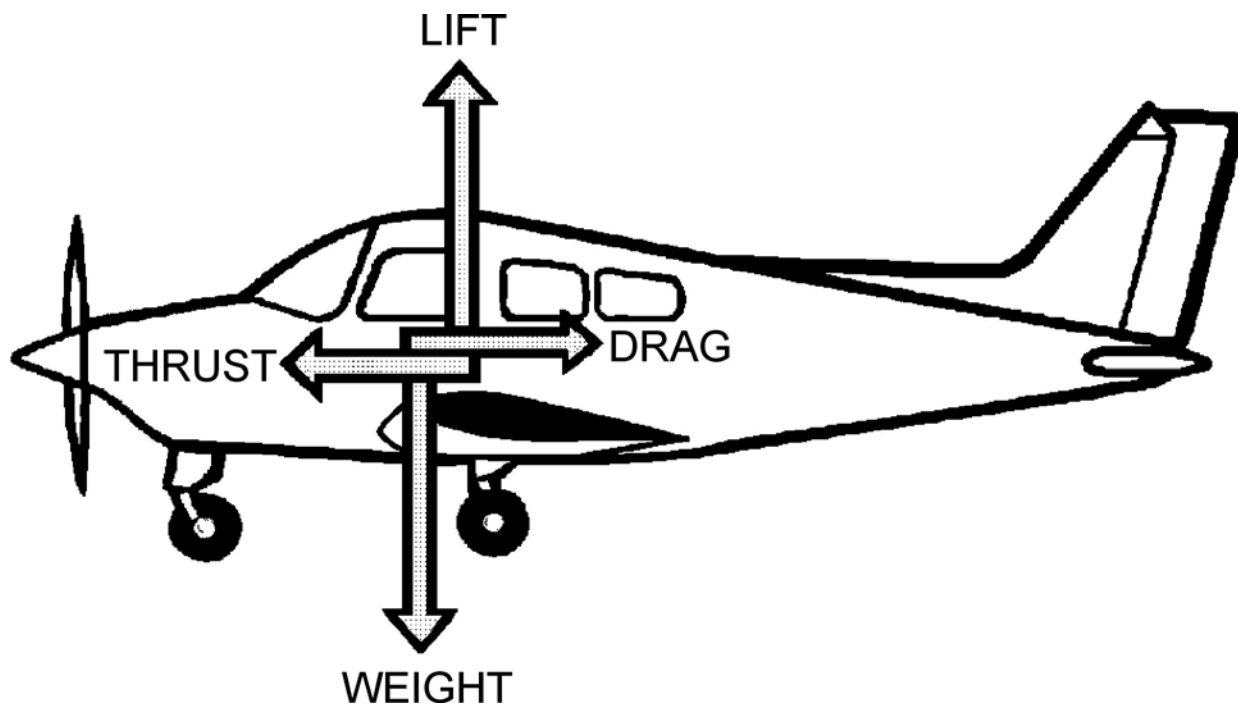

Cadets Canada: RCSU Pacific, 2007, Air Cadet Master Lesson Plans. Retrieved 7 March 2007, from http://www.regions.cadets.ca/pac/aircad/resources/mlp_air_e.asp

Figure 11B-1 The Four Forces That Act Upon an Aircraft

THIS PAGE INTENTIONALLY LEFT BLANK

IDENTIFYING THE FOUR FORCES THAT ACT UPON AN AIRCRAFT

**FILL IN EACH OF THE FOUR FORCES
NEXT TO THE ARROWS**

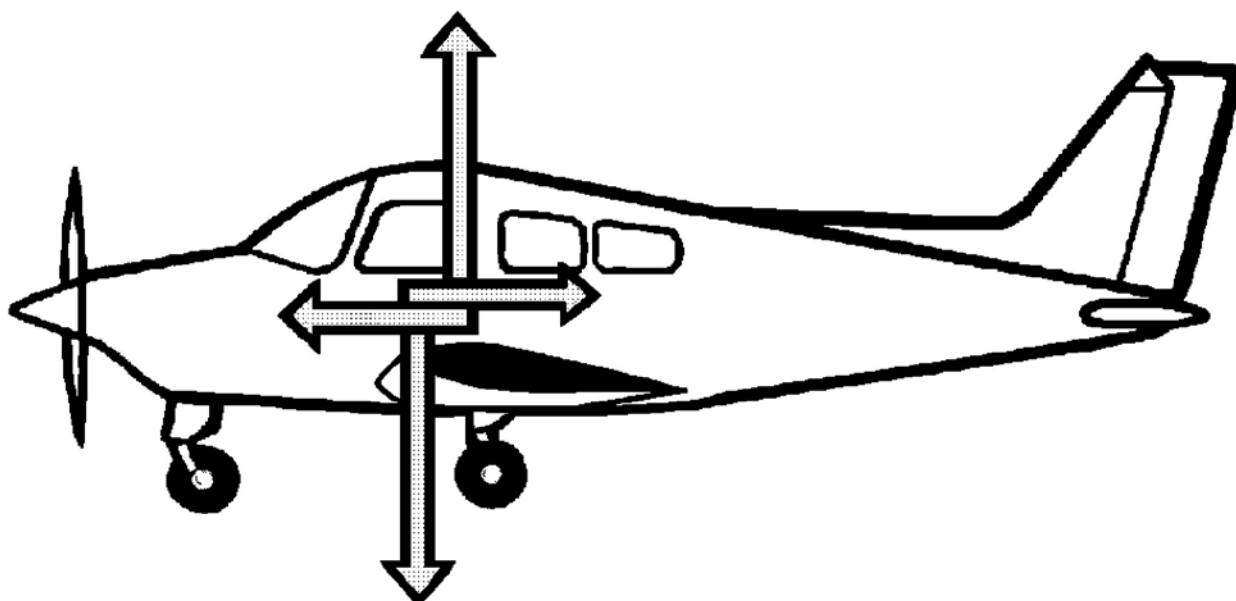

Cadets Canada: RCSU Pacific, 2007, Air Cadet Master Lesson Plans. Retrieved 7 March 2007, from http://www.regions.cadets.ca/pac/aircad/resources/mlp_air_e.asp

Figure 11C-1 Identifying the Four Forces That Act Upon an Aircraft

THIS PAGE INTENTIONALLY LEFT BLANK

PAPER AIRFOIL ACTIVITY

- BERNOULLI'S PRINCIPLE STATES THAT THE TOTAL ENERGY IN A SYSTEM REMAINS CONSTANT.
- A FLUID SYSTEM HAS ENERGY IN THE FORM OF SPEED AND PRESSURE.
- IF SPEED INCREASES, PRESSURE DECREASES AND IF SPEED DECREASES, PRESSURE INCREASES.



Cadets Canada: RCSU Pacific, 2007, Air Cadet Master Lesson Plans. Retrieved 7 March 2007, from http://www.regions.cadets.ca/pac/aircad/resources/mlp_air_e.asp

Figure 11D-1 Bernoulli's Principle

CREATING LIFT

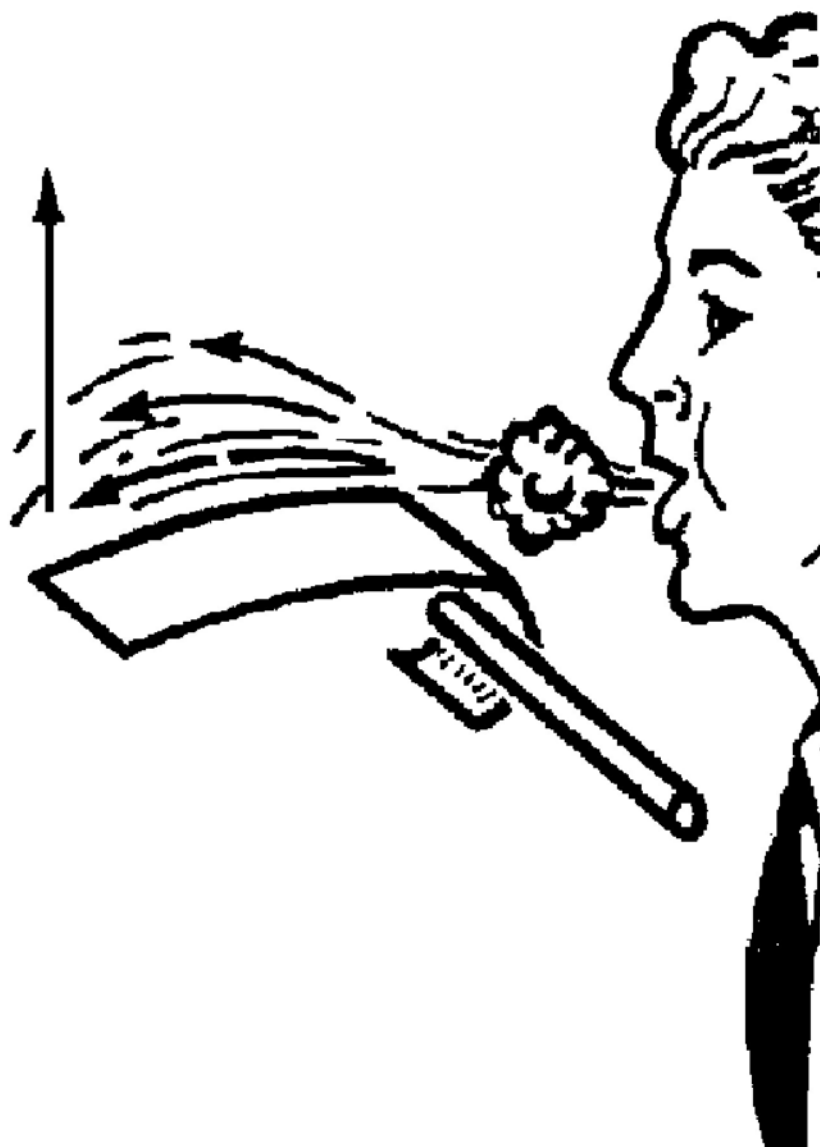

Cadets Canada: RCSU Pacific, 2007, Air Cadet Master Lesson Plans. Retrieved 7 March 2007, from http://www.regions.cadets.ca/pac/aircad/resources/mlp_air_e.asp

Figure 11D-2 Lift

AN AIRFOIL SECTION

AN AIRFOIL SECTION



Cadets Canada: RCSU Pacific, 2007, Air Cadet Master Lesson Plans. Retrieved 7 March 2007, from http://www.regions.cadets.ca/pac/aircad/resources/mlp_air_e.asp

Figure 11E-1 An Airfoil Section

THIS PAGE INTENTIONALLY LEFT BLANK

LIFT FROM AN AIRFOIL

LIFT PRODUCTION

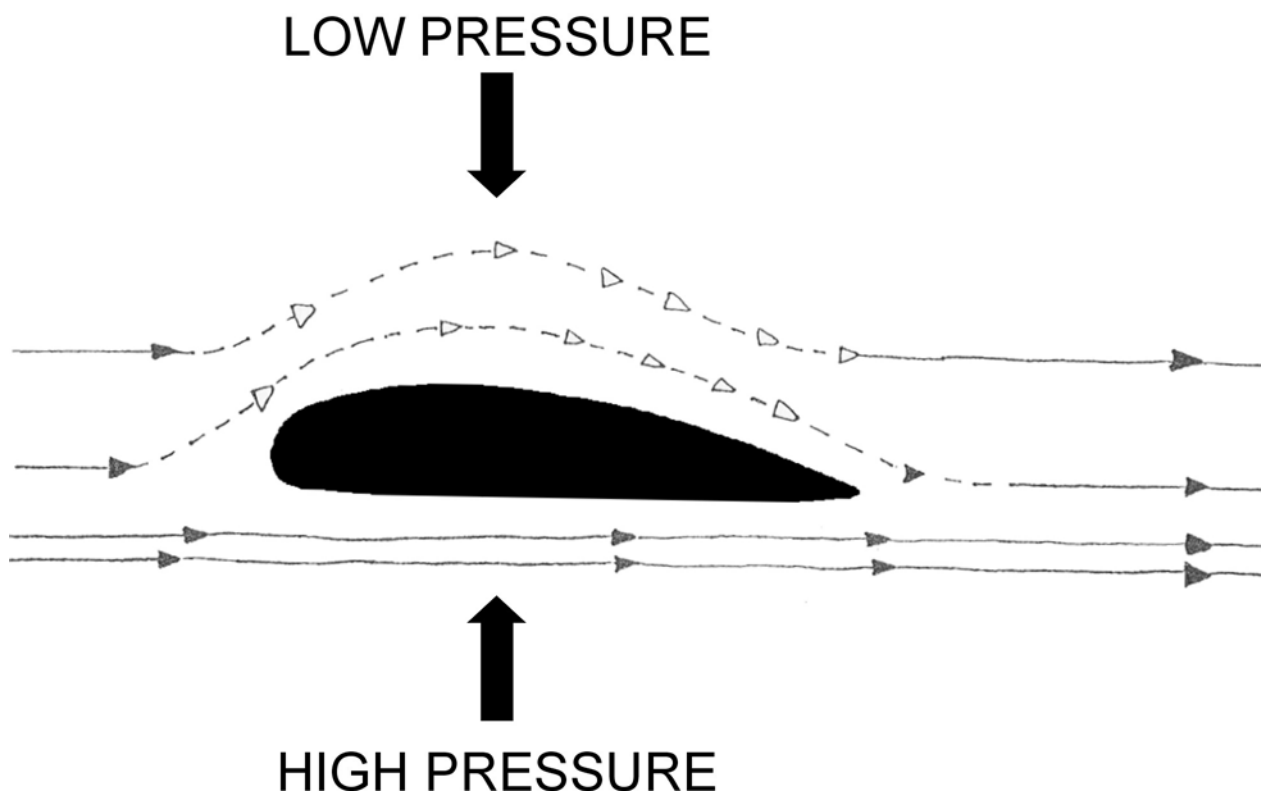

Cadets Canada: RCSU Pacific, 2007, Air Cadet Master Lesson Plans. Retrieved 7 March 2007, from http://www.regions.cadets.ca/pac/aircad/resources/mlp_air_e.asp

Figure 11F-1 Lift from an Airfoil

THIS PAGE INTENTIONALLY LEFT BLANK

DRAG DEFINITIONS

DRAG IS THE FORCE THAT OPPOSES THE FORWARD MOTION OF AN AIRCRAFT.

- THE TWO MAIN TYPES OF DRAG ARE **PARASITE DRAG** AND **INDUCED DRAG**.
- PARASITE DRAG IS FURTHER BROKEN INTO TWO TYPES, **FORM DRAG** AND **SKIN FRICTION**.

THIS PAGE INTENTIONALLY LEFT BLANK

PARASITE DRAG DEFINITIONS

PARASITE DRAG

PARASITE DRAG IS THE DRAG PRODUCED BY THOSE PARTS OF THE AIRCRAFT THAT DO NOT CONTRIBUTE TO THE PRODUCTION OF LIFT.

- **FORM DRAG** REFERS TO THE DRAG CREATED BY THE SHAPE OF A BODY AS IT RESISTS MOTION THROUGH THE AIR.
- **SKIN FRICTION** REFERS TO THE TENDENCY OF AIR FLOWING OVER A BODY TO CLING TO ITS SURFACE.

THIS PAGE INTENTIONALLY LEFT BLANK

INDUCED DRAG DEFINITIONS

INDUCED DRAG

- INDUCED DRAG IS THE DRAG PRODUCED BY THOSE PARTS OF THE AIRCRAFT THAT **ARE ACTIVE** IN THE PRODUCTION OF LIFT.
- IT IS THE RESULT OF THE WING'S WORK AND THEREFORE A PART OF LIFT AND CAN NEVER BE ELIMINATED.

THIS PAGE INTENTIONALLY LEFT BLANK

TYPES OF DRAG

TYPES OF DRAG

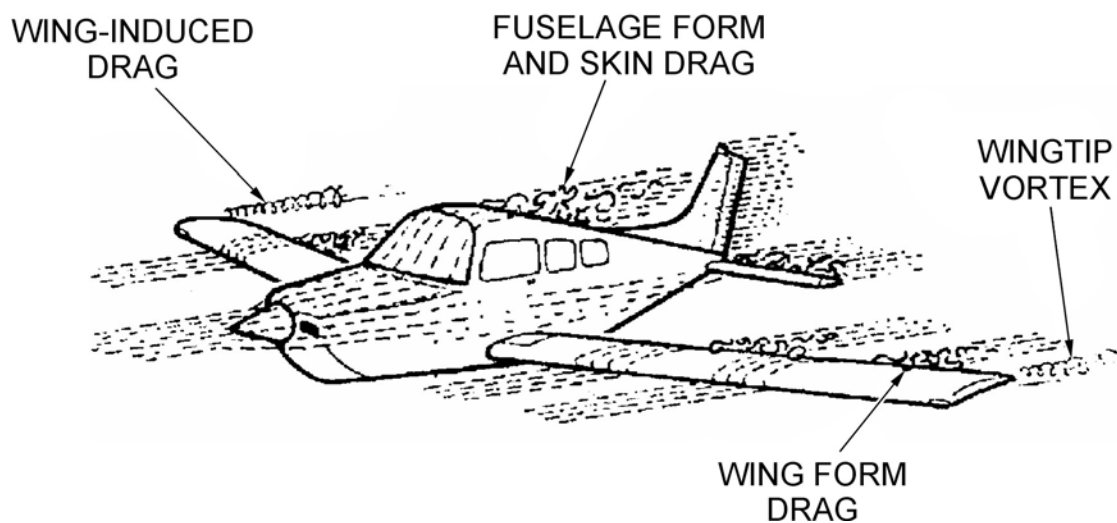

Cadets Canada: RCSU Pacific, 2007, Air Cadet Master Lesson Plans. Retrieved 7 March 2007, from http://www.regions.cadets.ca/pac/aircad/resources/mlp_air_e.asp

Figure 11J-1 Types of Drag on an Aircraft

PREVENTING WING TIP VORTICES

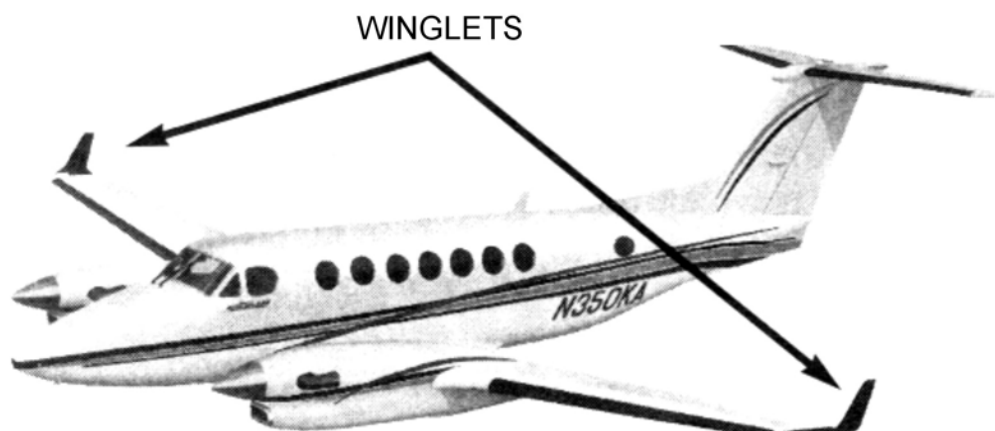

A-CR-CCP-263/PT-001 (p. 27)

Figure 11J-2 Winglets

AXES OF AN AIRCRAFT

AXIAL MOVEMENTS

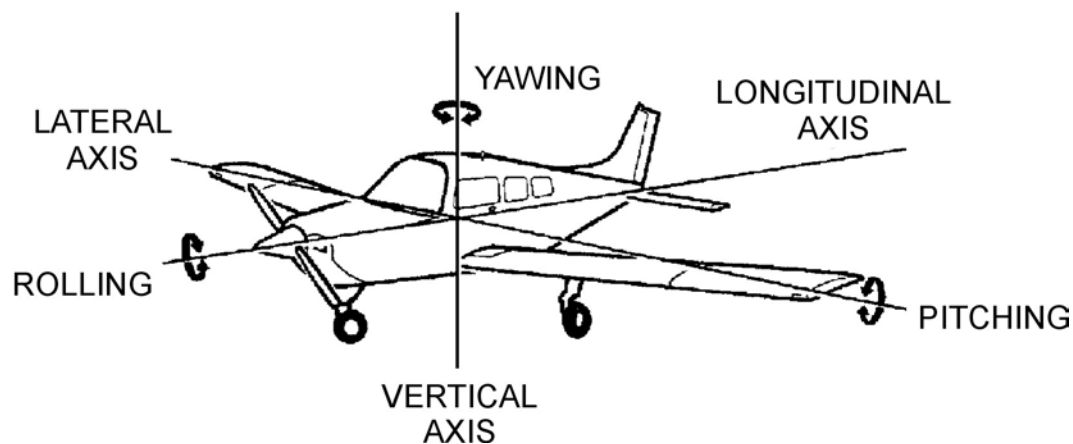

Cadets Canada: RCSU Pacific, 2007, Air Cadet Master Lesson Plans. Retrieved 7 March 2007, from http://www.regions.cadets.ca/pac/aircad/resources/mlp_air_e.asp

Figure 11K-1 Axes of an Aircraft

THIS PAGE INTENTIONALLY LEFT BLANK

IDENTIFYING AXES OF AN AIRCRAFT

LABEL THE FOLLOWING AXES AND
THE MOVEMENT ABOUT THEM.

NAME: _____

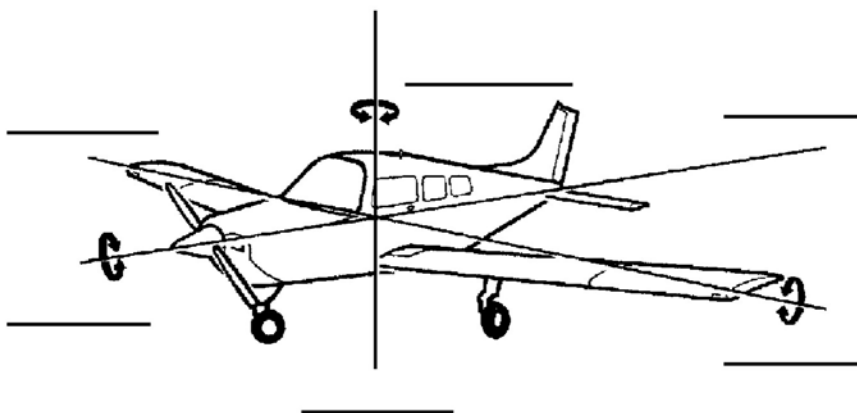

Cadets Canada: RCSU Pacific, 2007, Air Cadet Master Lesson Plans. Retrieved 7 March 2007, from http://www.regions.cadets.ca/pac/aircad/resources/mlp_air_e.asp

Figure 11L-1 Identifying Axes of an Aircraft

THIS PAGE INTENTIONALLY LEFT BLANK

AIRCRAFT CONTROL SURFACES

CONTROL SURFACES

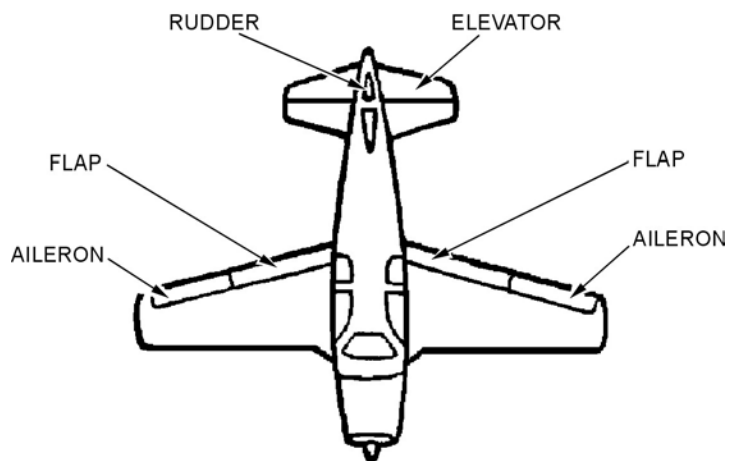

Cadets Canada: RCSU Pacific, 2007, Air Cadet Master Lesson Plans. Retrieved 7 March 2007, from http://www.regions.cadets.ca/pac/aircad/resources/mlp_air_e.asp

Figure 11M-1 The Control Surfaces of an Aircraft

THIS PAGE INTENTIONALLY LEFT BLANK

RUDDER CONTROL SYSTEM

THE RUDDER

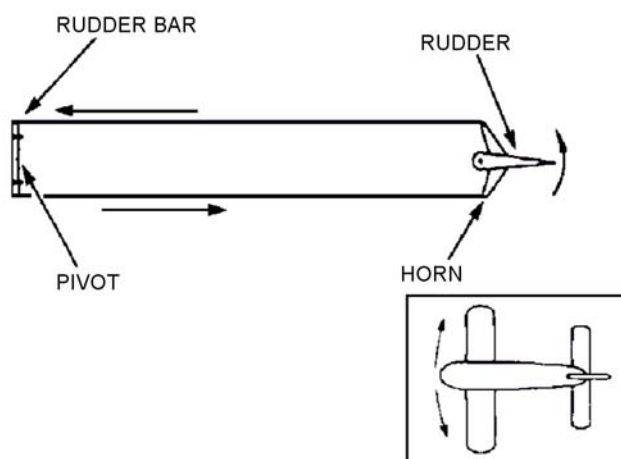

Cadets Canada: RCSU Pacific, 2007, Air Cadet Master Lesson Plans. Retrieved 7 March 2007, from http://www.regions.cadets.ca/pac/aircad/resources/mlp_air_e.asp

Figure 11N-1 Operation of a Rudder

THIS PAGE INTENTIONALLY LEFT BLANK

ELEVATOR CONTROL SYSTEM

THE ELEVATOR

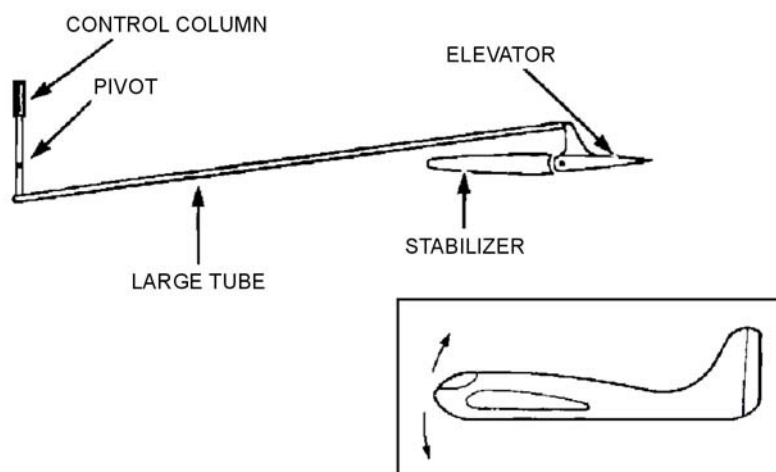

Cadets Canada: RCSU Pacific, 2007, Air Cadet Master Lesson Plans. Retrieved 7 March 2007, from http://www.regions.cadets.ca/pac/aircad/resources/mlp_air_e.asp

Figure 11O-1 Operation of an Elevator

THIS PAGE INTENTIONALLY LEFT BLANK

AILERON CONTROL SYSTEM

THE AILERONS

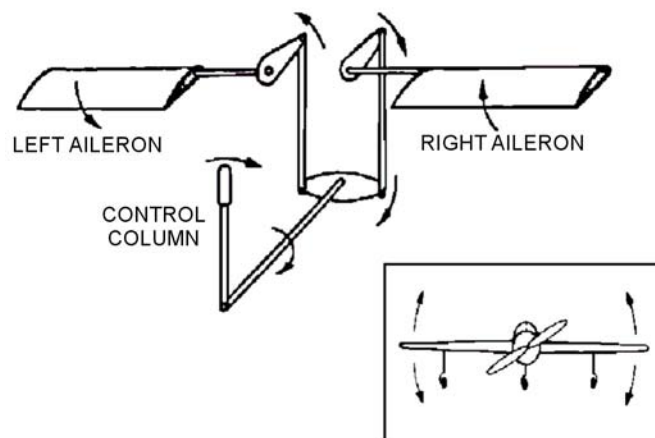

Cadets Canada: RCSU Pacific, 2007, Air Cadet Master Lesson Plans. Retrieved 7 March 2007, from http://www.regions.cadets.ca/pac/aircad/resources/mlp_air_e.asp

Figure 11P-1 Operation of Ailerons

THIS PAGE INTENTIONALLY LEFT BLANK

IDENTIFYING THE CONTROL SURFACES

CONTROL SURFACES

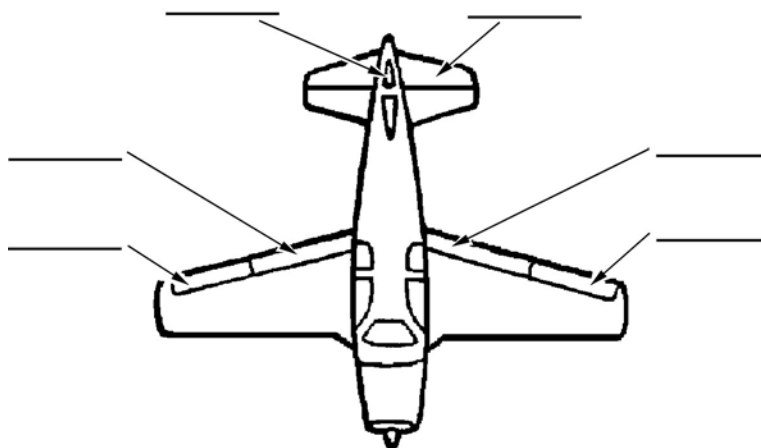

Cadets Canada: RCSU Pacific, 2007, Air Cadet Master Lesson Plans. Retrieved 7 March 2007, from http://www.regions.cadets.ca/pac/aircad/resources/mlp_air_e.asp

Figure 11Q-1 Identifying the Control Surfaces of an Aircraft

THIS PAGE INTENTIONALLY LEFT BLANK

WIND TUNNEL ACTIVITY

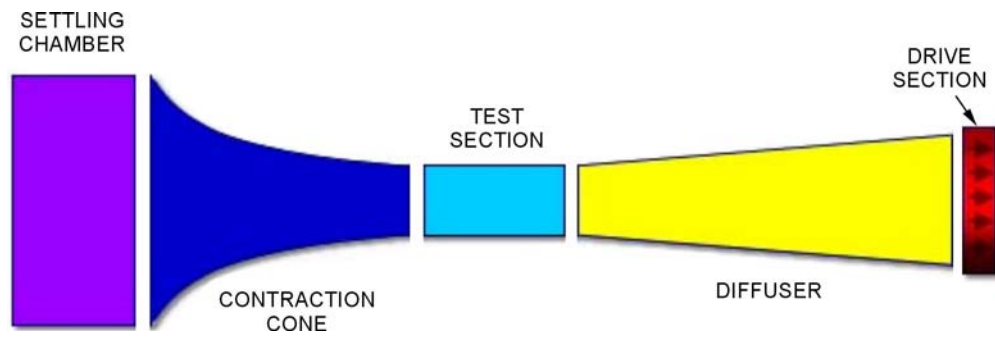

"NASA's Observatorium" Wind Tunnel Teacher's Guide. Retrieved 12 February 2007, from http://observe.arc.nasa.gov/nasa/aero/tunnel/tunnel_parts.html

Figure 11R-1 Parts of a Wind Tunnel

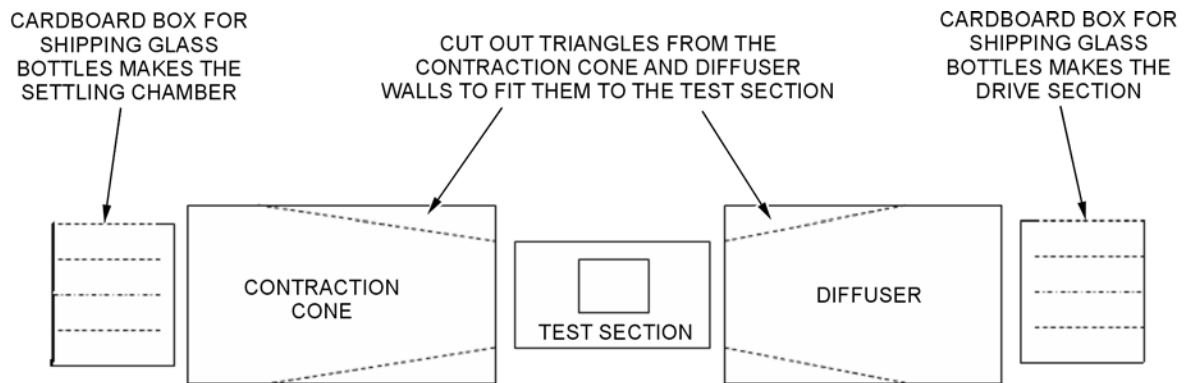

D Cds 3, 2007 Ottawa, ON: Department of National Defence

Figure 11R-2 Parts of a Cardboard Box Wind Tunnel

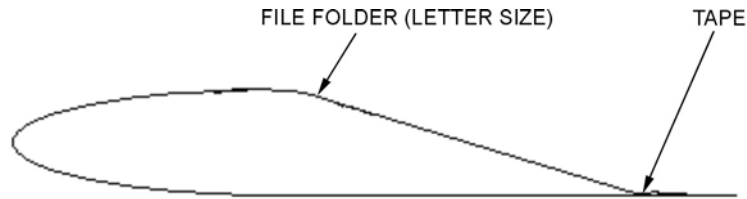

D Cds 3, 2007 Ottawa, ON: Department of National Defence

Figure 11R-3 File Folder Airfoil



Cadets Canada: RCSU Pacific, 2007, Air Cadet Master Lesson Plans. Retrieved 7 March 2007, from http://www.regions.cadets.ca/pac/aircad/resources/mlp_air_e.asp

Figure 11R-4 Airfoil Shape

COLDITZ PAPER GLIDER TEMPLATE AND ASSEMBLY INSTRUCTIONS

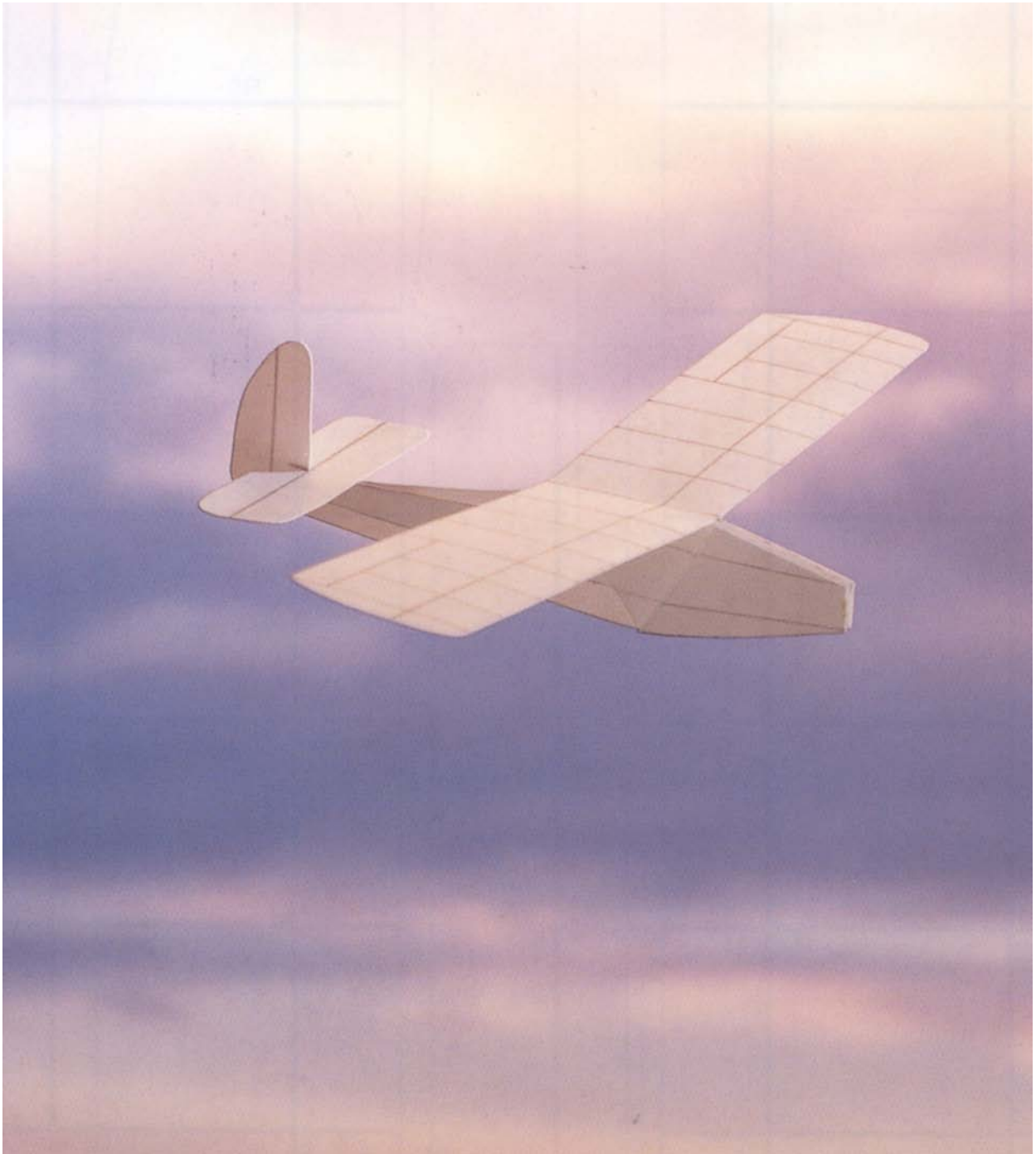

N. Schmidt, Fabulous Paper Gliders, Sterling Publishing Company (p. 52)

Figure 11S-1 Colditz Glider

INSTRUCTIONS

NOTE: ALSO REFER TO GENERAL INSTRUCTIONS ON PP 8-9.

- 1 SEE PAGES 12 AND 13 FOR THIS STEP
- 2 TACK-GLUE PARTS CUTTING GUIDES ONTO INDEX CARDS BY GLUING ON THE BACKSIDE BETWEEN THE PARTS.
- 3 SCORE THE FOLD LINES FOR WING AND TAIL TABS. (AFTER CUTTING OUT THE PIECES, BEND TABS OUTWARD.)
- 4 CUT EACH PIECE FROM THE INDEX CARD STOCK, REMOVE LIGHT-WEIGHT GUIDE PAPER AND DISCARD, LEAVING A CLEAN UNMARKED GLIDER PART.
- 5 GLUE PIECES 1F THROUGH 4R AND 4L TO BUILD UP FUSELAGE LAYERS. CAREFULLY ALIGNING PARTS.
- 6 GLUE 6W TO THE BOTTOM OF WING PART 5W.
- 7 APPLYING GLUE TO THE TAIL TABS, FASTEN HORIZONTAL STABILIZER 10S TO THE FUSELAGE.
- 8 APPLYING GLUE TO THE WING TABS, FASTEN WING ASSEMBLY TO THE FUSELAGE.
- 9 CAMBER THE WINGS BY CURVING THE PAPER GENTLY BETWEEN THUMB AND FOREFINGER. SEE BELOW.

NOTE: ENSURE THAT THE ENTIRE CONTACTING SURFACE OF A SMALLER PIECE BEING FASTENED TO A LARGER ONE IS COMPLETELY COVERED WITH GLUE.

NOTE: CUT CAREFULLY THROUGH BOTH SHEETS. THE CUTTING SIDE IS ALWAYS THE UPWARD OR OUTWARD FACING SURFACE OF THE FINISHED PART.

PRESS FUSELAGE FLAT BETWEEN CLEAN SHEETS OF PAPER UNDERNEATH A HEAVY WEIGHT (A FEW BIG BOOKS) UNTIL GLUE IS SUFFICIENTLY SET (ABOUT 45 MINUTES).

NOTE: MAKE SURE WING PARTS ARE ALIGNED ALONG THE CENTERLINE.

THE DIHEDRAL ANGLE OF THE WINGS MUST BE SET BEFORE THE GLUE DRIES. SEE BELOW.

DIHEDRAL: 3/4 in. (2 cm)

NOTE: AFTER COMPLETING THE GLIDER, IT IS IMPORTANT TO LET THE GLUE SET COMPLETELY (AN HOUR OR TWO) BEFORE FLYING.

POINT OF MAXIMUM CAMBER, 30% FROM FRONT

CAMBER.

CORRECT

TOO MUCH

N. Schmidt, *Fabulous Paper Gliders*, Sterling Publishing Company (p. 53)

Figure 11S-2 Colditz Glider Assembly

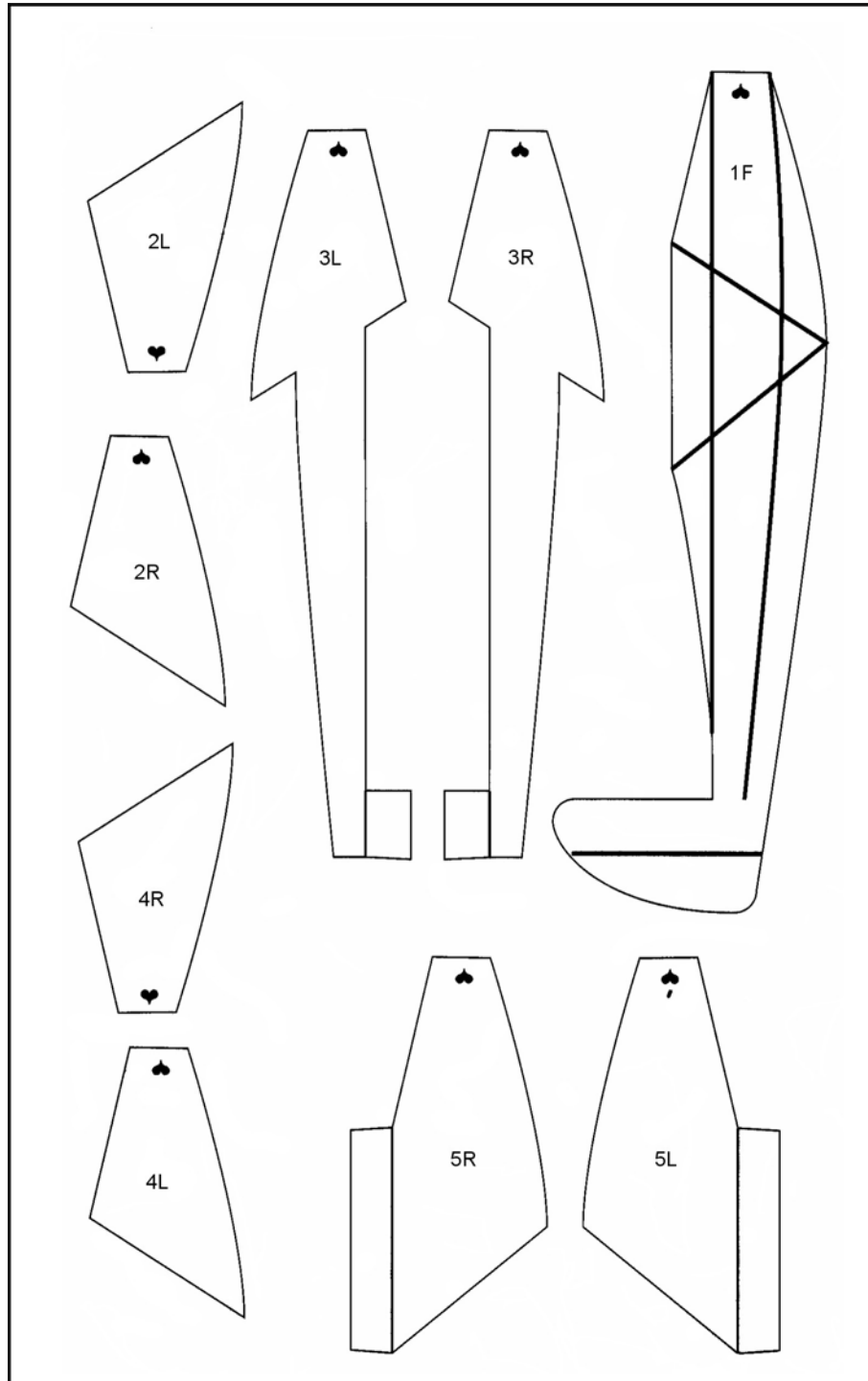

N. Schmidt, Fabulous Paper Gliders, Sterling Publishing Company (p. 54)

Figure 11S-3 Colditz Glider Fuselage

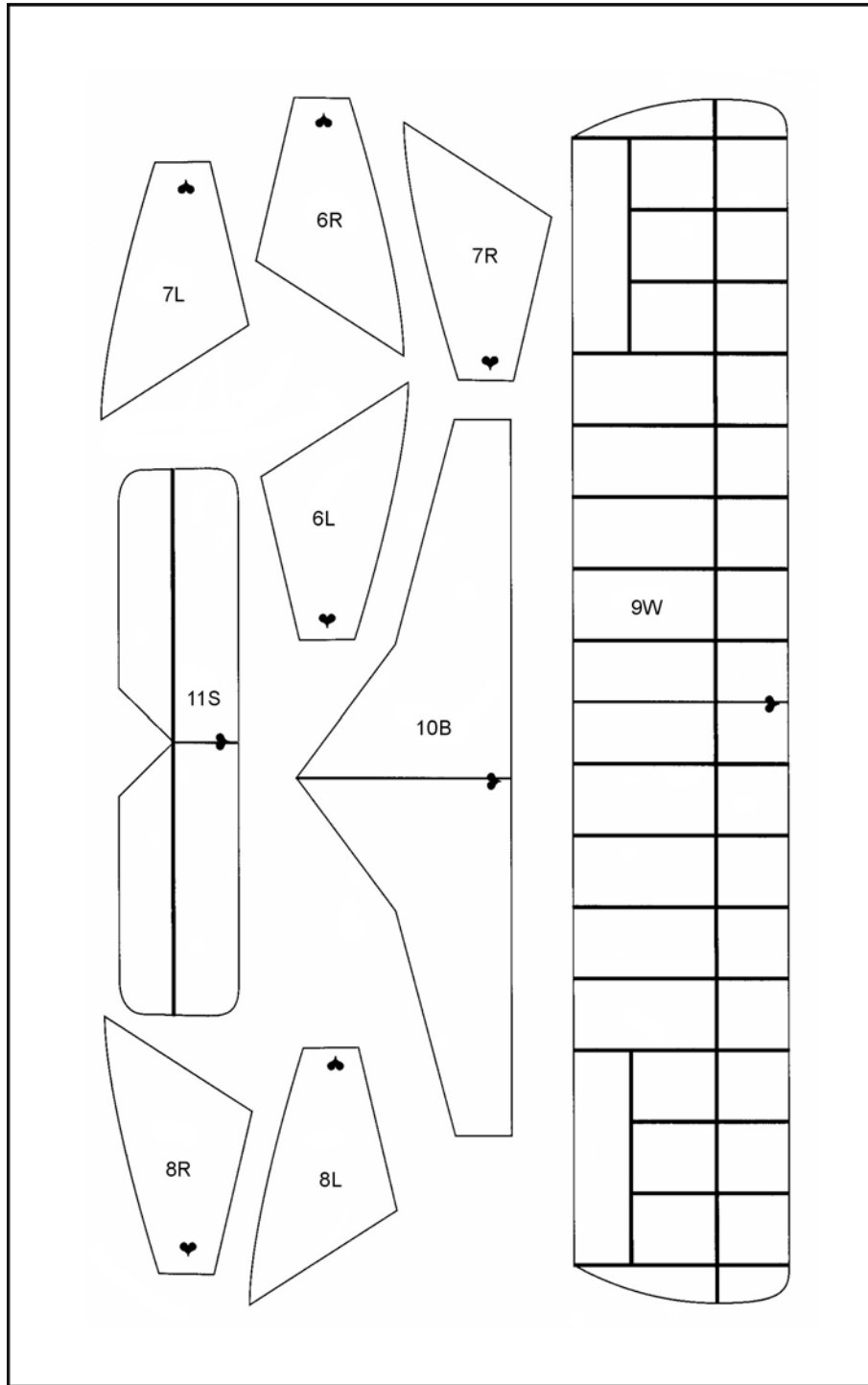

N. Schmidt, Fabulous Paper Gliders, Sterling Publishing Company (p. 55)

Figure 11S-4 Colditz Glider Wing